

California Environmental Protection Agency



Vapor Recovery Test Procedure

TP-201.3

**Determination of 2 Inch WC
Static Pressure Performance of Vapor Recovery
Systems of Dispensing Facilities**

Adopted: April 12, 1996
Amended: March 17, 1999
Amended: July 26, 2012

**California Environmental Protection Agency
Air Resources Board
Vapor Recovery Test Procedure**

TP-201.3

**Determination of 2 Inch WC Static Pressure Performance of
Vapor Recovery Systems of
Dispensing Facilities**

1 APPLICABILITY

Definitions common to all certification and test procedures are in:

D-200 Definitions for Vapor Recovery Procedures

For the purpose of this procedure, the term "ARB" or "CARB" refers to the California Air Resources Board, and the term "Executive Officer" refers to the ARB Executive Officer or his or her authorized representative or designate.

- 1.1 This test procedure is used to quantify the vapor tightness of vapor recovery systems installed at gasoline dispensing facilities (GDF) equipped with pressure/vacuum (P/V) valves, provided that the designed pressure setting of the P/V valves is a minimum of 2.5 inches of water column (inches H₂O).
- 1.2 Systems equipped with a P/V valve(s) allowed to have a designed cracking pressure less than 2.5 inches H₂O shall be bagged to eliminate any flow contribution through the valve assembly from the test results. The valve/vent pipe connection, however, shall remain unobstructed during this test.
- 1.3 At facilities not required to be equipped with a P/V valve(s), the vent pipe(s) shall be capped. For those installations, the test may be conducted at the vent pipe(s).

2 PRINCIPLE AND SUMMARY OF TEST PROCEDURE

- 2.1 The entire vapor recovery system is pressurized with nitrogen to two (2.0) inches H₂O. The system pressure is then allowed to decay and the pressure after five (5) minutes is compared with an allowable value. The minimum allowable five-minute final pressure is based on the system ullage and pressure decay equations. For the purpose of compliance determination, this test shall be conducted after all back-filling, paving, and installation of all Phase I and Phase II components, including P/V valves, has been completed.

- 2.2 For GDF equipped with a coaxial Phase I system, this test shall be conducted at a Phase II vapor riser. For GDF which utilize a two-point Phase I system, this test may be conducted at either a Phase II riser or a Phase I vapor coupler provided that the criteria set forth in Section 6.7 have been met. If the integrity criteria for two-point systems specified in Section 6.7 are met, it is recommended that this test be conducted at the Phase I vapor coupler.

3 RANGE

- 3.1 If mechanical pressure gauges are employed, the full-scale range of pressure gauges shall be 0-2.0, 0-1.0, and 0-0.50 inches H₂O column. Maximum incremental graduations of the pressure gauge shall be 0.05 inches H₂O and the minimum accuracy of the gauge shall be three percent of full scale. The minimum diameter of the pressure gauge face shall be 4 inches.
- 3.2 If an electronic pressure measuring device is used, the full-scale range of the device shall not exceed 0-10 inches H₂O with a minimum accuracy of 0.5 percent of full-scale. A 0-20 inches H₂O device may be used, provided the equivalent accuracy is not less than 0.25 percent of full-scale.
- 3.3 The minimum total ullage, for each individual tank, shall be 1,000 gallons or 25% of the tank capacity, whichever is less. The maximum total ullage, for all manifolded tanks, shall not exceed 25,000 gallons. These values are exclusive of all vapor piping volumes.
- 3.4 The minimum and maximum nitrogen feed-rates, into the system, shall be one (1) and five (5) CFM, respectively.

4 INTERFERENCES

- 4.1 Introduction of nitrogen into the system at flowrates exceeding five (5) CFM may bias the results of the test toward non-compliance. Only gaseous nitrogen shall be used to conduct this test. Air, liquefied nitrogen, helium, or any gas other than nitrogen shall not be used for this test procedure.
- 4.2 For vacuum-assist Phase II systems which utilize an incinerator, power to the collection unit and the processor shall be turned off during testing.
- 4.3 For vacuum-assist systems, with positive displacement vacuum pumps, which locate the vacuum producing device in-line between the Phase II vapor riser and the storage tank, the following requirements shall apply:
- 4.3.1 A valve shall be installed at the vacuum producing device. When closed, this valve shall isolate the vapor passage downstream of the vacuum producing device.

- 4.3.2 The storage tank side of the vacuum producing device shall be tested in accordance with the procedures outlined in Section 7 of this method. Compliance shall be determined by comparing the final five-minute pressure with the allowable minimum five-minute final pressure from the first column (1-6 affected nozzles) in Table IB or use the corresponding equation in Section 9.2.
- 4.3.3 The upstream vapor passage (nozzle to vacuum producing device) shall also be tested. Methodology for this test shall be submitted to the California Air Resources Board (CARB) for approval prior to submission of test results or shall be conducted in accordance with the procedures set forth in the applicable CARB Executive Order.
- 4.4 The results of this static pressure integrity test shall not be used to verify compliance if an Air to Liquid Volumetric Ratio Test (TP-201.5 or equivalent) was conducted within 24 hours prior to this test.
- 4.5 Thermal Bias for Electronic Manometers
- Electronic manometers shall have a warm-up period of at least 15 minutes followed by a five minute drift check. If the drift exceeds 0.01 inches water column, the instrument should not be used.

5 APPARATUS

5.1 Nitrogen

Use commercial grade nitrogen in a high pressure cylinder, equipped with a two-stage pressure regulator and a one psig pressure relief valve.

5.2 Pressure Measuring Device

Use 0-2.0, 0-1.0, and 0-0.50 inches H₂O pressure gauges connected in parallel, a 0-2 inches H₂O manometer, or an electronic pressure measuring device to monitor the pressure decay in the vapor recovery system. The pressure measuring device shall, at a minimum, be readable to the nearest 0.05 inches H₂O.

5.3 "T" Connector Assembly

See Figure 1 for example.

5.4 Vapor Coupler Integrity Assembly

Assemble OPW 633-A, 633-B, and 634-A adapters, or equivalent, as shown in Figure 2. If the test is to be conducted at the storage tank Phase I vapor

coupler, this assembly shall be used prior to conducting the static leak test in order to verify the pressure integrity of the vapor poppet. The internal volume of this assembly shall not exceed 0.1 cubic feet.

5.5 Vapor Coupler Test Assembly

Use a compatible OPW 634-B cap, or equivalent, equipped with a center probe to open the poppet, a pressure measuring device to monitor the pressure decay, and a connection for the introduction of nitrogen into the system. See Figure 3 for an example.

5.6 Stopwatch

Use a stopwatch accurate to within 0.2 seconds.

5.7 Flow Meter

Use a Dwyer flowmeter, Model RMC-104, or equivalent, to determine the required pressure setting of the delivery pressure gauge on the nitrogen supply pressure regulator. This pressure shall be set such that the nitrogen flowrate is between 1.0 and 5.0 CFM.

5.8 Combustible Gas Detector

A Bacharach Instrument Company, Model 0023-7356, or equivalent, may be used to verify the pressure integrity of system components during this test.

5.9 Leak Detection Solution

Any liquid solution designed to detect vapor leaks may be used to verify the pressure integrity of system components during this test.

6 PRE-TEST PROCEDURES

6.1 The following safety precautions shall be followed:

6.1.1 Only nitrogen shall be used to pressurize the system.

6.1.2 A one psig relief valve shall be installed to prevent the possible over-pressurizing of the storage tank.

6.1.3 A ground strap should be employed during the introduction of nitrogen into the system.

6.2 Failure to adhere to any or all of the following time and activity restrictions shall

invalidate the test results:

- 6.2.1 There shall be no Phase I bulk product deliveries into or out of the storage tank(s) within the three (3) hours prior to the test or during performance of this test procedure.
- 6.2.2 There shall be no product dispensing within thirty (30) minutes prior to the test or during performance of this test procedure.
- 6.2.3 Upon commencement of the thirty minute “no dispensing” portion of this procedure, the headspace pressure in the tank shall be measured. If the pressure exceeds 0.50 inches H₂O, the pressure shall be carefully relieved in accordance with all applicable safety requirements. After the thirty minute “no dispensing” portion of this procedure, and prior to introduction of nitrogen, the headspace pressure shall again be lowered, if necessary, to less than 0.50 inches H₂O.
- 6.2.4 There shall be no Air to Liquid Volumetric Ratio Test (TP-201.5 or equivalent) conducted within the twenty-four (24) hour period immediately prior to this test.
- 6.2.5 The test shall be conducted with the station in normal operating mode. This includes all nozzles properly hung up in the dispenser boots and all dispenser cabinet covers in place. The exception to normal operating mode is that dispensing is disallowed as specified.
- 6.3 Measure the gallons of gasoline present in each underground storage tank and determine the actual capacity of each storage tank from facility records. Calculate the ullage space for each tank by subtracting the gasoline gallonage present from the actual tank capacity. The minimum ullage during the test, for all manifolded tanks, shall be 1,000 gallons or 25 percent of the tank capacity, whichever is less. The total ullage, for all manifolded tanks, shall not exceed 25,000 gallons.
- 6.4 For two-point Phase I systems, this test shall be conducted with the dust cap removed from both the product and the vapor coupler. This is necessary to determine the vapor tightness of the Phase I vapor poppet. See Section 6.7 if this test is to be conducted at the Phase I vapor coupler.
 - 6.4.1 For coaxial Phase I systems, this test shall be conducted with the dust cap removed from the Phase I coupler. This is necessary to insure the vapor tightness of the Phase I vapor poppet.
 - 6.4.2 Verify that the liquid level in the storage tank is at least four (4) inches above the highest opening at the bottom of the submerged drop tube.

- 6.5 If the Phase I containment box is equipped with a drain valve, this test shall be conducted with the drain valve installed and the manhole cover removed. If the drain valve is cover-actuated, the test shall be done once with the cover removed and repeated with the cover installed.
- 6.6 If the test is to be conducted at a Phase II vapor riser, disconnect the dispenser end of one vapor recovery hose and install the "T" connector assembly (see Figure 1). Connect the nitrogen gas supply (do not use air) and the pressure measuring device to the "T" connector.
- 6.6.1 For those Phase II vapor systems utilizing a dispenser mounted remote vapor check valve, the "T" connector assembly shall be installed on the vapor riser side of the check valve.
- 6.7 If this test is to be conducted at the Phase I vapor coupler on a two-point Phase I system, the procedures set forth in subsections 6.7.1 and 6.7.2 shall be successfully completed prior to testing. The static pressure integrity test shall not be conducted at the Phase I coupler at facilities equipped with coaxial Phase I systems.
- 6.7.1 Connect the Vapor Coupler Integrity Assembly to the Phase I vapor coupler. Connect the Vapor Coupler Test Assembly. Connect the nitrogen supply to the assembly and carefully pressurize the internal volume of the assembly to two (2.0) inches H₂O. Start the stopwatch. Record the final pressure after one minute.
- 6.7.2 If the pressure after one minute is less than 0.25 inches H₂O, the leak rate through the Phase I vapor poppet precludes conducting the static leak test at this location. If the pressure after one minute is greater than or equal to 0.25 inches H₂O, the static leak test may be conducted at this location. This criteria assures a maximum leak rate through the Phase I vapor poppet of less than 0.0004 cubic feet per minute.
- 6.7.3 Disconnect the Vapor Coupler Integrity Assembly to the Phase I vapor coupler. If the requirements of subsection 6.7.2 were met, connect the Vapor Coupler Test Assembly to the Phase I vapor coupler.
- 6.7.4 Product may be poured onto the Phase I vapor coupler to check for leaks. This diagnostic procedure shall not be substituted for the procedures set forth in subsections 6.7.1 and 6.7.2.
- 6.8 All pressure measuring device(s) shall be bench calibrated using either a reference gauge or incline manometer. Calibration shall be performed at 20, 50, and 80 percent of full scale. Accuracy shall be within two percent at each of these calibration points. Calibrations shall be conducted on a frequency not to exceed 90 days.

- 6.9 Use the flowmeter to determine the nitrogen regulator delivery pressures which correspond to nitrogen flowrates of 1.0 and 5.0 CFM. These pressures define the allowable range of delivery pressures acceptable for this test procedure. Also record the regulator delivery pressure setting, and the corresponding nitrogen flowrate that will be used during the test. As an alternative, the flowmeter may be connected, in-line between the nitrogen supply regulator and Vapor Coupler Test Assembly, during the test.
- 6.10 Use Equation 9.3 to calculate the approximate time required to pressurize the system ullage to the initial starting pressure of two (2.0) inches H₂O. This will allow the tester to minimize the quantity of nitrogen introduced into those systems which cannot comply with the static leak standards.
- 6.11 Attach the Vapor Coupler Test assembly to the Phase I poppet or the "T" connector assembly to the Phase II vapor riser. Read the initial pressure of the storage tank and underground piping. If the initial pressure is greater than 0.5 inches H₂O, carefully bleed off the pressure, in accordance with all applicable safety procedures, in the storage tank and underground piping to less than 0.5 inches H₂O column.
- 6.12 Any electronic manometers shall be subject to warm-up and drift check before use; see Section 4.5.

7 TESTING

- 7.1 Open the nitrogen gas supply valve and set the regulator delivery pressure within the allowable range determined in Section 6.9, and start the stopwatch. Pressurize the vapor system (or subsystem for individual vapor return line systems) to **at least 2.2 inches H₂O** initial pressure. It is critical to maintain the nitrogen flow until the pressure stabilizes, indicating temperature and vapor pressure stabilization in the tanks. Check the test equipment using leak detecting solution or a combustible gas detector to verify that all test equipment is leak tight. Note: if a combustible gas detector is used to search for leaks, components which were certified with an allowable leak rate, such as 0.38 CFH at a pressure of two (2) inches, cannot be determined to be faulty solely on the basis of the concentration registered on the instrument.
- 7.1.1 If the time required to achieve the initial pressure of two (2.0) inches H₂O exceeds twice the time derived from Equation 9.3, stop the test and use liquid leak detector, or a combustible gas detector, to find leak(s) in the system. Failure to achieve the initial starting pressure within twice the time derived from Equation 9.3 demonstrates the inability of the system to meet the performance criteria. Repair or replace the faulty component(s) and restart the test pursuant to Section 7.1.

- 7.2 Close and disconnect the nitrogen supply. Start the stopwatch when the pressure has decreased to the initial starting pressure of two (2.0) inches H₂O.
- 7.3 At one-minute intervals during the test, record the system pressure. After five minutes, record the final system pressure. See the applicable of Tables 1A (or Equation 9.1) or 1B (or equation 9.2) to determine the acceptability of the final system static pressure results. For intermediate values of ullage in Tables 1A and 1B, linear interpolation may be employed.
- 7.4 If the system failed to meet the criteria set forth in Table 1A or 1B (or the appropriate equation in Section 9), repressurize the system and check all accessible vapor connections using leak detector solution or a combustible gas detector. If vapor leaks in the system are encountered, repair or replace the defective component and repeat the test. Potential sources of leaks include nozzle check valves, nozzle vapor paths, pressure/vacuum relief valves, containment box drain valve assemblies, and plumbing connections at the risers.
- 7.4.1 If the facility fails to comply with the static leak test standards and the two point Phase I system utilizes overfill prevention devices in the drop tubes which were installed before July 1, 1993, and which are unable to pass the test with the dust caps removed from the product and vapor couplers (see Sec. 6.4), the test may be conducted with the caps on the couplers, as an exception.
- This exception is not intended to allow bleed holes in drop tubes.
- This exception expires on January 1, 2002, after which date all testing shall be conducted with the fill and vapor caps removed from two point systems. Under no circumstances may the test be conducted with the caps on coaxial Phase I couplers.
- 7.5 After the remaining system pressure has been relieved, remove the "T" connector assembly and reconnect the vapor recovery hose, if applicable.
- 7.6 If the vapor recovery system utilizes individual vapor return lines, repeat the leak test for each gasoline grade. Avoid leaving any vapor return line open longer than is necessary to install or remove the "T" connector assembly.
- 7.7 If the applicable CARB Executive Order requires the test to be conducted with and without the containment box cover in place, repeat the test with the cover in place. In these cases clearly specify, on Form 1, which results represent the pressure integrity with and without the cover in place.

8 POST-TEST PROCEDURES

- 8.1 Use the applicable of Table 1A or 1B, or the applicable of Equations 9.1 or 9.2, to determine the compliance status of the facility by comparing the final five-minute pressure with the minimum allowable final pressure.
- 8.1.1 For balance Phase II systems use Table 1A or the applicable of Equation 9.1 to determine compliance.
- 8.1.2 For vacuum-assist Phase II systems use Table 1B or the applicable of Equation 9.2 to determine compliance.

9 CALCULATIONS

- 9.1 For Phase II Balance Systems, the minimum allowable five-minute final pressure, with an initial pressure of two (2.0) inches H₂O, shall be calculated as follows:

$$P_f = 2e^{\left(\frac{-760.490}{V}\right)} \quad \text{if } N = 1 - 6 \quad \text{[Equation 9-1]}$$

$$P_f = 2e^{\left(\frac{-792.196}{V}\right)} \quad \text{if } N = 7 - 12$$

$$P_f = 2e^{\left(\frac{-824.023}{V}\right)} \quad \text{if } N = 13 - 18$$

$$P_f = 2e^{\left(\frac{-855.974}{V}\right)} \quad \text{if } N = 19 - 24$$

$$P_f = 2e^{\left(\frac{-888.047}{V}\right)} \quad \text{if } N > 24$$

where:

N = The number of affected nozzles. For manifolded systems, N equals the total number of nozzles. For dedicated plumbing configurations, N equals the number of nozzles serviced by the tank being tested.

P_f = The minimum allowable five-minute pressure, inches H₂O

V = The total ullage affected by the test, gallons

e = A dimensionless constant approximately equal to 2.718

2 = The initial starting pressure, inches H₂O

9.2 For Phase II Vacuum Assist Systems, the minimum allowable five-minute final pressure, with an initial pressure of two (2.0) inches H₂O, shall be calculated as follows:

$$P_f = 2e^{\left(\frac{-500.887}{V}\right)} \quad \text{if } N = 1 - 6 \quad \text{[Equation 9-2]}$$

$$P_f = 2e^{\left(\frac{-531.614}{V}\right)} \quad \text{if } N = 7 - 12$$

$$P_f = 2e^{\left(\frac{-562.455}{V}\right)} \quad \text{if } N = 13 - 18$$

$$P_f = 2e^{\left(\frac{-593.412}{V}\right)} \quad \text{if } N = 19 - 24$$

$$P_f = 2e^{\left(\frac{-624.483}{V}\right)} \quad \text{if } N > 24$$

where:

N = The number of affected nozzles. For manifolded systems, N equals the number of nozzles. For dedicated plumbing configurations, N equals the number of nozzles serviced by the tank being tested.

P_f = The minimum allowable five-minute final pressure, inches H₂O

V = The total ullage affected by the test, gallons

e = A dimensionless constant approximately equal to 2.718

2 = The initial starting pressure, inches H₂O

9.3 The minimum time required to pressurize the system ullage from zero (0) to two (2.0) inches H₂O gauge pressure shall be calculated as follows:

$$t_2 = \frac{V}{(1522)F} \quad \text{[Equation 9-3]}$$

where:

t_2 = The minimum time to pressurize the ullage to two inches H₂O, minutes

V = The total ullage affected by the test, gallons

F = The nitrogen flowrate into the system, CFM

1522 = The conversion factor for pressure and gallons

- 9.4 If the policy of the local District requires an allowable tolerance for testing error, the minimum allowable five-minute final pressure, including testing error, shall be calculated as follows:

$$P_{f-E} = 2 - \left[1 + \left(\frac{E}{100} \right) \right] [408.9 - (P_f + 406.9)] \quad \text{[Equation 9-4]}$$

where:

P_{f-E} = The minimum allowable five-minute final pressure including allowable testing error, inches H₂O

E = The allowable testing error, percent

P_f = The minimum allowable five-minute final pressure calculated in Equations 9-1 or 9-2, inches H₂O

2 = The initial starting pressure, inches H₂O

408.9 = Atmospheric pressure plus the initial starting pressure, inches H₂O

406.9 = Atmospheric pressure, inches H₂O

10 REPORTING

- 10.1 The calculated ullage and system pressures for each five-minute vapor recovery system test shall be reported as shown in Form 1. District may require the use of alternate forms, provided they include the same minimum parameters identified in Form 1. Be sure to include the Phase I system type (two-point or coaxial), the Phase II system type, whether the system is manifolded, and the one-minute pressures during the test.

TABLE 1A
PHASE II BALANCE SYSTEMS
PRESSURE DECAY CRITERIA
INITIAL PRESSURE OF 2 INCHES WATER COLUMN (WC)
MINIMUM PRESSURE AFTER 5 MINUTES, INCHES WC

ULLAGE, GALLONS	NUMBER OF AFFECTED NOZZLES				
	<u>01-06</u>	<u>07-12</u>	<u>13-18</u>	<u>19-24</u>	<u>>24</u>
500	0.44	0.41	0.38	0.36	0.34
550	0.50	0.47	0.45	0.42	0.40
600	0.56	0.53	0.51	0.48	0.46
650	0.62	0.59	0.56	0.54	0.51
700	0.67	0.64	0.62	0.59	0.56
750	0.73	0.70	0.67	0.64	0.61
800	0.77	0.74	0.71	0.69	0.66
850	0.82	0.79	0.76	0.73	0.70
900	0.86	0.83	0.80	0.77	0.75
950	0.90	0.87	0.84	0.81	0.79
1,000	0.93	0.91	0.88	0.85	0.82
1,200	1.06	1.03	1.01	0.98	0.95
1,400	1.16	1.14	1.11	1.09	1.06
1,600	1.24	1.22	1.19	1.17	1.15
1,800	1.31	1.29	1.27	1.24	1.22
2,000	1.37	1.35	1.32	1.30	1.28
2,200	1.42	1.40	1.38	1.36	1.34
2,400	1.46	1.44	1.42	1.40	1.38
2,600	1.49	1.47	1.46	1.44	1.42
2,800	1.52	1.51	1.49	1.47	1.46
3,000	1.55	1.54	1.52	1.50	1.49
3,500	1.61	1.59	1.58	1.57	1.55
4,000	1.65	1.64	1.63	1.61	1.60
4,500	1.69	1.68	1.67	1.65	1.64
5,000	1.72	1.71	1.70	1.69	1.67
6,000	1.76	1.75	1.74	1.73	1.72
7,000	1.79	1.79	1.78	1.77	1.76
8,000	1.82	1.81	1.80	1.80	1.79
9,000	1.84	1.83	1.83	1.82	1.81
10,000	1.85	1.85	1.84	1.84	1.83
15,000	1.90	1.90	1.89	1.89	1.89
20,000	1.93	1.91	1.92	1.92	1.91
25,000	1.94	1.94	1.94	1.93	1.93

Note: For manifolded Phase II Balance Systems, the “Number of Affected Nozzles” shall be the total of all gasoline nozzles. For dedicated return configurations, the “Number of Affected Nozzles” shall be the total of those nozzles served by the tank being tested.

TABLE 1B
PHASE II ASSIST SYSTEMS
PRESSURE DECAY CRITERIA
INITIAL PRESSURE OF 2 INCHES WATER COLUMN (WC)
MINIMUM PRESSURE AFTER 5 MINUTES, INCHES WC

ULLAGE, GALLONS	NUMBER OF AFFECTED NOZZLES				
	<u>01-06</u>	<u>07-12</u>	<u>13-18</u>	<u>19-24</u>	<u>>24</u>
500	0.73	0.69	0.65	0.61	0.57
550	0.80	0.76	0.72	0.68	0.64
600	0.87	0.82	0.78	0.74	0.71
650	0.93	0.88	0.84	0.80	0.77
700	0.98	0.94	0.90	0.86	0.82
750	1.03	0.98	0.94	0.91	0.87
800	1.07	1.03	0.99	0.95	0.92
850	1.11	1.07	1.03	1.00	0.96
900	1.15	1.11	1.07	1.03	1.00
950	1.18	1.14	1.11	1.07	1.04
1,000	1.21	1.18	1.14	1.10	1.07
1,200	1.32	1.28	1.25	1.22	1.19
1,400	1.40	1.37	1.34	1.31	1.28
1,600	1.46	1.43	1.41	1.38	1.35
1,800	1.51	1.49	1.46	1.44	1.41
2,000	1.56	1.53	1.51	1.49	1.46
2,200	1.59	1.57	1.55	1.53	1.51
2,400	1.62	1.60	1.58	1.56	1.54
2,600	1.65	1.63	1.61	1.59	1.57
2,800	1.67	1.65	1.64	1.62	1.60
3,000	1.69	1.68	1.66	1.64	1.62
3,500	1.73	1.72	1.70	1.69	1.67
4,000	1.76	1.75	1.74	1.72	1.71
4,500	1.79	1.78	1.77	1.75	1.74
5,000	1.81	1.80	1.79	1.78	1.77
6,000	1.84	1.83	1.82	1.81	1.80
7,000	1.86	1.85	1.85	1.84	1.83
8,000	1.88	1.87	1.86	1.86	1.85
9,000	1.89	1.89	1.88	1.87	1.87
10,000	1.90	1.90	1.89	1.88	1.88
15,000	1.93	1.93	1.93	1.92	1.92
20,000	1.95	1.95	1.94	1.94	1.94
25,000	1.96	1.96	1.96	1.95	1.95

Note: For manifolded Phase II Assist Systems, the “Number of Affected Nozzles” shall be the total of all gasoline nozzles. For dedicated return configurations, the “Number of Affected Nozzles” shall be the total of those nozzles served by the tank being tested.

FORM 1

SUMMARY OF SOURCE TEST DATA

SOURCE INFORMATION		FACILITY PARAMETERS																																																													
GDF Name and address _____ _____ _____	GDF Representative and Title _____ _____ GDF Phone No. (____) _____	PHASE II SYSTEM TYPE (Check One)																																																													
Permit Conditions	Source: GDF Vapor Recovery System GDF # _____ A/C # _____	Balance _____ Hirt _____ Red Jacket _____ Hasstech _____ Healy _____ Other _____	_____ _____ _____ _____ _____																																																												
	Operating Parameters Number of Nozzles Served by Tank #1 _____ Number of Nozzles Served by Tank #3 _____ Number of Nozzles Served by Tank #2 _____ Number of Nozzles Served by Tank #4 _____		Manifoldded? Y or N																																																												
Applicable Regulations:		VN Recommended																																																													
Source Test Results and Comments <u>Tank #:</u>																																																															
<table style="width: 100%; border-collapse: collapse;"> <thead> <tr> <th style="width: 60%;"></th> <th style="width: 10%; text-align: center;">1</th> <th style="width: 10%; text-align: center;">2</th> <th style="width: 10%; text-align: center;">3</th> <th style="width: 10%; text-align: center;">4</th> </tr> </thead> <tbody> <tr> <td>1. Product Grade</td> <td style="text-align: center;">_____</td> <td style="text-align: center;">_____</td> <td style="text-align: center;">_____</td> <td style="text-align: center;">_____</td> </tr> <tr> <td>2. Actual Tank Capacity, gallons</td> <td style="text-align: center;">_____</td> <td style="text-align: center;">_____</td> <td style="text-align: center;">_____</td> <td style="text-align: center;">_____</td> </tr> <tr> <td>3. Gasoline Volume</td> <td style="text-align: center;">_____</td> <td style="text-align: center;">_____</td> <td style="text-align: center;">_____</td> <td style="text-align: center;">_____</td> </tr> <tr> <td>4. Ullage, gallons (#2-#3)</td> <td style="text-align: center;">_____</td> <td style="text-align: center;">_____</td> <td style="text-align: center;">_____</td> <td style="text-align: center;">_____</td> </tr> <tr> <td>5. Initial Pressure, inches H₂O</td> <td style="text-align: center;">_____</td> <td style="text-align: center;">_____</td> <td style="text-align: center;">_____</td> <td style="text-align: center;">_____</td> </tr> <tr> <td>6. Pressure After 1 Minute, inches H₂O</td> <td style="text-align: center;">_____</td> <td style="text-align: center;">_____</td> <td style="text-align: center;">_____</td> <td style="text-align: center;">_____</td> </tr> <tr> <td>7. Pressure After 2 Minutes, inches H₂O</td> <td style="text-align: center;">_____</td> <td style="text-align: center;">_____</td> <td style="text-align: center;">_____</td> <td style="text-align: center;">_____</td> </tr> <tr> <td>8. Pressure After 3 Minutes, inches H₂O</td> <td style="text-align: center;">_____</td> <td style="text-align: center;">_____</td> <td style="text-align: center;">_____</td> <td style="text-align: center;">_____</td> </tr> <tr> <td>9. Pressure After 4 Minutes, inches H₂O</td> <td style="text-align: center;">_____</td> <td style="text-align: center;">_____</td> <td style="text-align: center;">_____</td> <td style="text-align: center;">_____</td> </tr> <tr> <td>10. Final Pressure After 5 Minutes, inches H₂O</td> <td style="text-align: center;">_____</td> <td style="text-align: center;">_____</td> <td style="text-align: center;">_____</td> <td style="text-align: center;">_____</td> </tr> <tr> <td>11. Allowable Final Pressure</td> <td style="text-align: center;">_____</td> <td style="text-align: center;">_____</td> <td style="text-align: center;">_____</td> <td style="text-align: center;">_____</td> </tr> </tbody> </table>					1	2	3	4	1. Product Grade	_____	_____	_____	_____	2. Actual Tank Capacity, gallons	_____	_____	_____	_____	3. Gasoline Volume	_____	_____	_____	_____	4. Ullage, gallons (#2-#3)	_____	_____	_____	_____	5. Initial Pressure, inches H ₂ O	_____	_____	_____	_____	6. Pressure After 1 Minute, inches H ₂ O	_____	_____	_____	_____	7. Pressure After 2 Minutes, inches H ₂ O	_____	_____	_____	_____	8. Pressure After 3 Minutes, inches H ₂ O	_____	_____	_____	_____	9. Pressure After 4 Minutes, inches H ₂ O	_____	_____	_____	_____	10. Final Pressure After 5 Minutes, inches H ₂ O	_____	_____	_____	_____	11. Allowable Final Pressure	_____	_____	_____	_____
	1	2	3	4																																																											
1. Product Grade	_____	_____	_____	_____																																																											
2. Actual Tank Capacity, gallons	_____	_____	_____	_____																																																											
3. Gasoline Volume	_____	_____	_____	_____																																																											
4. Ullage, gallons (#2-#3)	_____	_____	_____	_____																																																											
5. Initial Pressure, inches H ₂ O	_____	_____	_____	_____																																																											
6. Pressure After 1 Minute, inches H ₂ O	_____	_____	_____	_____																																																											
7. Pressure After 2 Minutes, inches H ₂ O	_____	_____	_____	_____																																																											
8. Pressure After 3 Minutes, inches H ₂ O	_____	_____	_____	_____																																																											
9. Pressure After 4 Minutes, inches H ₂ O	_____	_____	_____	_____																																																											
10. Final Pressure After 5 Minutes, inches H ₂ O	_____	_____	_____	_____																																																											
11. Allowable Final Pressure	_____	_____	_____	_____																																																											
Test Conducted by:	Test Company:	Date of Test:																																																													

Figure 1
"T" Connector Assembly

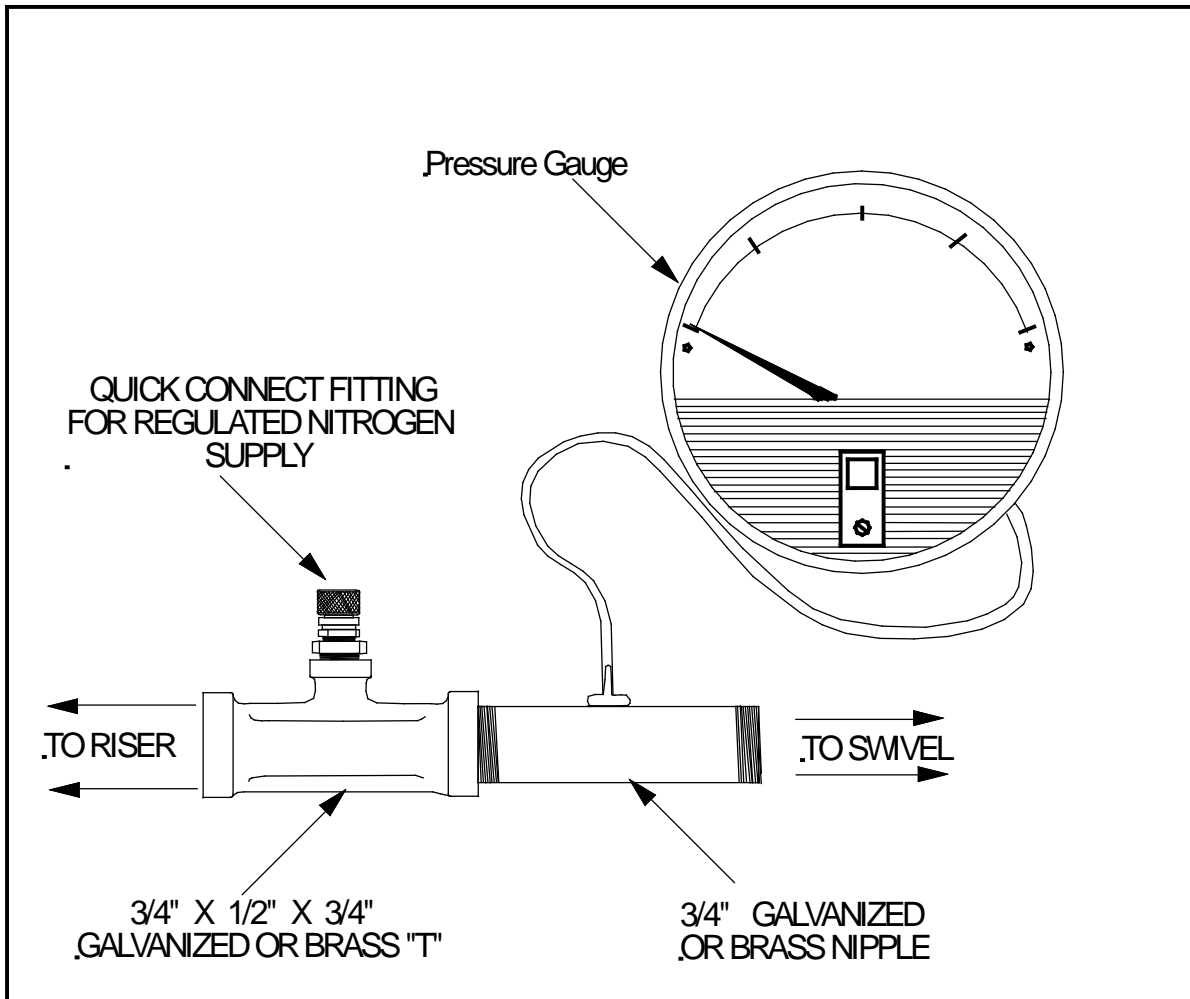

Figure 2

Vapor Coupler Integrity Assembly

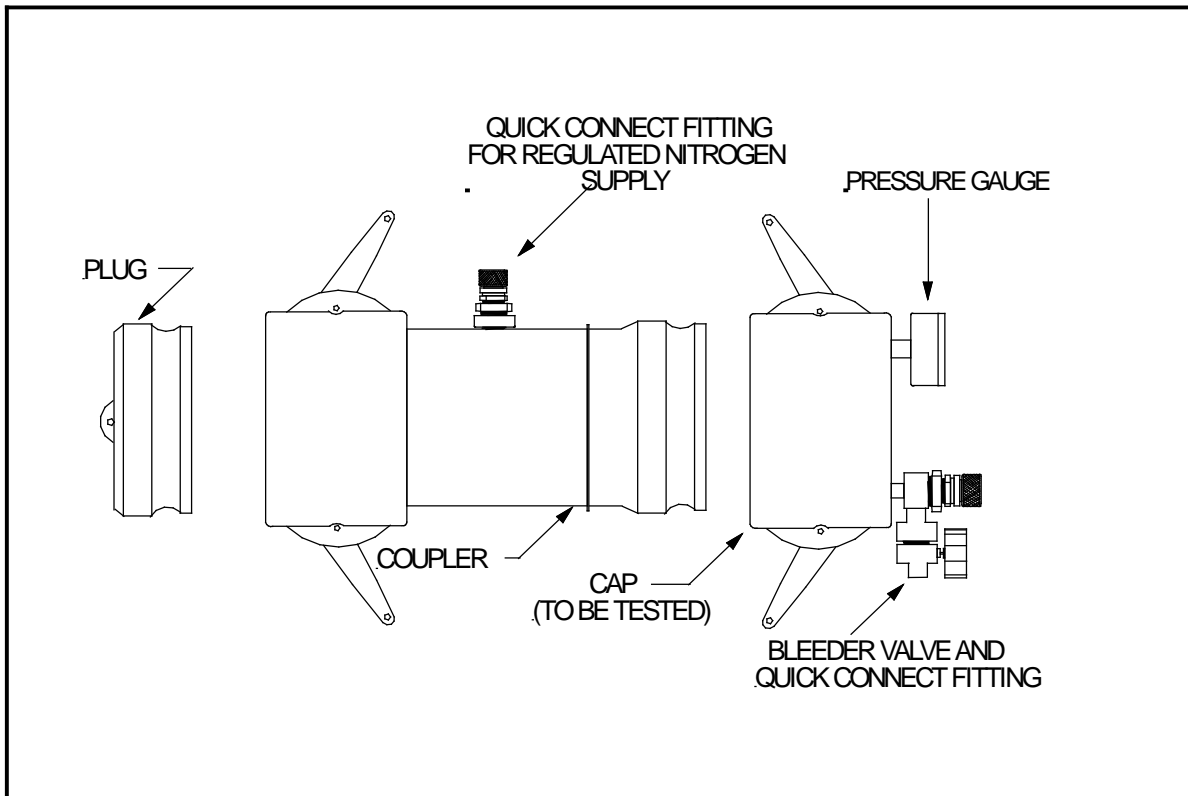

Figure 3

Vapor Coupler Test Assembly

