

California Environmental Protection Agency



ARB Approved

Installation, Operation and Maintenance Manual

For

Executive Order

VR-101-Q

Franklin Fueling Systems, Inc.

Phil-Tite/EBW/FFS Phase I Vapor Recovery System

NOTICE:

The **ARB Approved Installation, Operation and Maintenance Manual for the Franklin Fueling System Phase I EVR System** describes the tools and methods required to install the FFS Phase I EVR System. Unless specified otherwise, only technicians that are trained and certified by FFS (i.e. FFS Certified Technicians) are able to perform installation, maintenance or repairs of components manufactured by FFS or the warranty will be void. A list of FFS Certified Technicians can be viewed at <http://www.franklinfueling.com/service/>.

To schedule a training class, FFS can be contacted at the following:

Enhanced Vapor Recovery Systems
Franklin Fueling Systems
Phone: 800-225-9787
Email: techserve@franklinfueling.com

It is the responsibility of each FFS Certified Technician to be familiar with the current requirements of state, federal and local codes for installation and repair of gasoline dispensing equipment. It is also the responsibility of the FFS Certified Technician to be aware of all necessary safety precautions and site safety requirements to assure a safe and trouble free installation.

In addition to the requirements included in this manual, the contractor is responsible for providing the warranty tag, included with each component, to the service station owner/operator at the time of installation.

Summary of Maintenance Activities Required of the FFS Phase I Vapor Recovery System¹		
Component	Interval	Maintenance To Be Performed
Spill Container Drain Valve Phil-Tite “All Models with Drain Valves”	Every 3 years following startup or following Spill Container Installation	<ul style="list-style-type: none"> • Inspect the black spill container and remove any standing liquid, grit, sand, debris or dirt from inside the spill container. • Perform ARB test procedure TP-201.1C – Leak Rate of Drop Tube/Spill Drain Valve Assemblies. • If the drain valve assembly, drop tube and spill container passes testing, no further maintenance is necessary. If the drop tube, or the drain valve assembly, or the spill container fails testing perform the steps listed below. <p>Spill Container with Drain Valve Maintenance Instructions</p> <ul style="list-style-type: none"> • Check the product swivel adaptor for any leakage. Replace the ¼” flat seal (85039) if suspected of leaking; see product and vapor swivel adaptor maintenance. Any leakage from the swivel adaptor seal or thru the swivel adaptor will mask the test results toward failure. Eliminate any leakage thru the product swivel adaptor. • If the spill container drain valve is suspected of leaking perform steps 1 thru 5. • If the spill container to riser adaptor/tank riser flat seal and/or the drop tube seal are suspected of leaking, perform steps 6 thru 10. <p><i>Note: For ARB FFS EVR Phil-Tite Spill Container Installations the drop tube must be installed under the spill container. If not this could possibly be the source of any leaks. Install the drop tube under the spill container.</i></p> <ol style="list-style-type: none"> 1. Remove the stainless retainer-ring from the inside of the spill container. Ensure the gray foam filter (602026001) is free of any debris, grit, sand, dirt, and liquid. The purpose of the foam filter is to trap and hold any debris (grit, dirt, sand, etc.) from reaching the drain valve and drain holes, blocking them from draining properly. This filter greatly improves the longevity and proper operation of the drain valve assembly. Replace the foam filter (602026001) if it is torn, has tears, and/or is damaged. 2. With the retainer ring removed, loosen and remove the drain valve top hex screw from the top clamp. With the drain valve handle position in the middle of the spill container remove the drain valve and handle assembly by pulling up on the drain valve handle.
(Spill Container Drain Valve continued next page) Spill Container Drain	Every 3	<ol style="list-style-type: none"> 3. Inspect the drain valve-screen assembly and ensure

¹ These maintenance requirements shall not circumvent use of the manufacturer’s installation and maintenance instructions. Maintenance contractors or owner/operators shall refer to the manufacturers complete installation and maintenance instructions found herein to ensure that all maintenance and torque requirements are met. Maintenance must be conducted within the interval specified from the date of installation and at least within the specified interval thereafter.

Summary of Maintenance Activities Required of the FFS Phase I Vapor Recovery System¹		
Component	Interval	Maintenance To Be Performed
Valve (continued) Phil-Tite “All Models with Drain Valves”	years following startup or following Spill Container Installation	there are no cracks or cuts. Inspect the shut-off collar for nicks, cuts, wrapped, etc. If the above are damage, replace the drain valve assembly (85400). 4. Remove any liquid and debris (sand, grit, dirt, dust, etc.) that may be under the drain valve assembly. Check the drain valve “O”-Ring (85035) for any wear, cuts, tears and debris. Clean and/or replace if necessary. 5. Reinstall the drain valve and handle assembly (85400) using the Installation and Adjustment instructions found within IOM. Check the drain valve handle for proper operation. NOTE: The drain valve handle must snap into place when moved to the closed position! Re-adjust if necessary. 6. Remove the black spill container using an approved installation/extraction tool (T-7101 or T-7002, Black) from Phil-Tite T-7043 Tool Kit. 7. Inspect the ¼” flat seal (85039) (black spill container to M/F 4X4 riser adaptor seal) for cuts or damage, replace if necessary. 8. If there is no M/F 4X4 riser adaptor installed on top of the tank riser this could be the reason for failing TP-201.1C performance test. Install a Phil-Tite M/F 4X4 Riser Adaptor. Note: Install only one (1) M/F 4X4 Riser adaptor per tank riser. Two or more on top of a single tank riser will cause test failures. 9. Inspect the drop tube round seal for correct installation, cuts or damage, replace if necessary (85039-DT). Note: The drop tube seal must be Phil-Tite’s special round seal (85039-DT), Do Not use a standard ‘O’-Ring. 10. Reinstall the black spill container using the installation instructions provided, and perform ARB test procedure TP-201.1C – Leak Rate of Drop Tube/ Drain Valve Assembly.
(Spill Container Drain Valve continued next page) (Spill Container Drain	Every 3	1. Perform ARB test procedure TP-201.1C – Leak

Summary of Maintenance Activities Required of the FFS Phase I Vapor Recovery System¹		
Component	Interval	Maintenance To Be Performed
Valve continued) Defender Series with EBW 70533729 EBW Series with 70533719 Drain Valve	years following startup or following spill container installation	Rate of Drop Tube/Drain Valve assembly. 2. Clean any sand, gravel, or dirt from the snow plow ring. Buildup of material will prevent the manhole lid from sitting flat and diverting rain water. In addition to water infiltration, this can lead to premature lid failures and tripping hazards. 3. Inspect the cover gasket and replace if necessary. 4. Inspect the spill container for the presence of liquid. If any is present, identify the material (water or fuel) and dispose of it using your preferred acceptable method (pump it out or drain it into the tank). 5. Inspect the primary spill container and drain valve screen for any foreign material collecting in the area. Remove any large objects, (leaves, rags, etc.) and wipe the bottom of the tank with a disposable rag. <i>Note: For Defender EVR installations, the Defender Spill Container is installed first on the UST Fill Riser. The Drop Tube is installed through the installed spill container before installing the Drop Tube Riser Clamp inside the spill container.</i> 6. Inspect the entire spill container assembly and any components for obvious damage. Verify that all components are functioning properly. 7. Record inspection results per local codes.

1

¹ These maintenance requirements shall not circumvent use of the manufacturer's installation and maintenance instructions. Maintenance contractors or owner/operators shall refer to the manufacturers complete installation and maintenance instructions found herein to ensure that all maintenance and torque requirements are met. Maintenance must be conducted within the interval specified from the date of installation and at least within the specified interval thereafter.

Summary of Maintenance Activities Required of the FFS Phase I Vapor Recovery System ¹ (continued)		
Component	Interval	Maintenance To Be Performed
Pressure/Vacuum Vent Valve FFS Model 407215901 PV-Zero (Gas/E85)	Annual	<ol style="list-style-type: none"> 1. Visual inspect housing, pipe, fittings and rain cap for obvious signs of damage, missing parts or fluid leaks. 2. Visually inspect the rain cap, from ground level, for signs of bird nests or insect activity. 3. Every year, drain and inspect the fill fluid per the Fluid Inspection Procedure.
Pressure/Vacuum Vent Valve Husky Model 5885 (Gasoline Blends Only)	Annual	<ol style="list-style-type: none"> 1. Remove screws that hold top cover on. 2. Remove any debris that might be sitting inside the lower cover. 3. Check the drain holes in the lower cover for blockage. 4. Do not remove the two (2) screens. 5. Reinstall the top cover and retaining screws. 6. Tighten the screws firmly.
Pressure/Vacuum Vent Valve OPW Model 723V (Gasoline Blends Only)	Annual	<p>Upper Screen Maintenance</p> <ol style="list-style-type: none"> 1. Remove vent top by depressing tabs and lift top upwards. 2. Clean and replace filter screen as necessary. 3. Reinstall vent top by inserting into the body. <p>Lower Screen Maintenance</p> <ol style="list-style-type: none"> 1. Remove valve assembly from pipe adaptor. Grip assembly at the flats just above the pipe adaptor and unscrew. 2. Lift the filter screen out and clean or replace as necessary. 3. Reinstall filter screen in the pipe adaptor. 4. Reinstall valve assembly on pipe adaptor and tighten.
Dust Caps	Annual	Visually inspect the seal in cap and replace if damaged or missing.
Drop Tubes OPW 61T EBW 782-204-1 EBW 782-204-3	Annual	<ul style="list-style-type: none"> • Visually inspect Drop Tube to see if it is installed and ensure that the bottom of tube is within 6 inches of the bottom of tank. • Test the drop tube seal with ARB procedure TP-201.1C. If the drop tube seal passes testing, no further maintenance is required. If the drop tube seal fails testing, replace the drop tube seal with Phil-Tite 85039-DT "O"-ring. • Re-test the drop tube seal with ARB procedure TP-201.1C.
Overfill Prevention Devices	Annual	<ul style="list-style-type: none"> • Annually, inspect the valve for any noticeable damage by looking down the drop tube opening. If any damage is observed, the valve must be replaced. • Test the seals with ARB procedure TP-201.1D. If the drop tube passes testing, no further maintenance is required. If the drop tube fails testing, replace the drop tube seal with Phil-Tite 85039-DT. • Re-test the valve with ARB procedure TP-201.1D. If this does not correct the leak the valve needs to be replaced.

¹ These maintenance requirements shall not circumvent use of the manufacturer's installation and maintenance instructions. Maintenance contractors or owner/operators shall refer to the manufacturers complete installation and maintenance instructions found herein to ensure that all maintenance and torque requirements are met. Maintenance must be conducted within the interval specified from the date of installation and at least within the specified interval thereafter.

Summary of Maintenance Activities Required of the FFS Phase I Vapor Recovery System ¹ (continued)		
Component	Interval	Maintenance To Be Performed
Vapor Recovery Adaptor Phil-Tite SWV-101-B and SWV-101-SS	Annual	<p><i>The Phil-Tite rotatable adaptors are not field serviceable, with the exception of the vapor swivel poppet 'O'-Ring found on the Vapor swivel adaptor (SWV-101-B and SWV-101-SS).</i></p> <p>The swivel tops should rotate 360 degrees by hand. If you can rotate the swivel tops by hand you are applying less than 108 in. lbs. of static torque.</p> <p>If a leak is found in the vapor top poppet, inspect the brass/stainless steel vapor top for 'out of round' condition. Check the poppet 'O'-Ring seal for sand, dirt, dust, grit and abrasions between the poppet 'O'-Ring and the brass/stainless steel sealing surface. (These conditions are not covered by the warranty.)</p> <p>To check and/or replace the vapor swivel poppet 'O'-Ring:</p> <ol style="list-style-type: none"> 1. Remove the vapor swivel adaptor (SWV-101-B or SWV-101-SS) from the black spill container riser using the special tool adaptor (T-7102, orange) from the Phil-Tite Tool Kit (T-7043). 2. Using a small blade common screwdriver remove the ¼ inch flat seal gasket from the bottom of the vapor adaptor. 3. Push down on the brass/stainless steel spider a ½ inch or so, using a small blade common screwdriver, remove the retainer ring. (Warning: The spider and spring assembly are spring loaded.) This will release the spider assembly, spring, and poppet assembly. By hand, carefully remove these parts. 4. With the vapor poppet assembly removed, inspect the poppet and poppet 'O'-Ring for cuts, tears or damage. Replace the 'O'-Ring if necessary. Before re-assembly spray a small amount of Silicone Spray on the poppet 'O'-Ring. NOTE: DO NOT USE ANY TYPE OF OIL OR GREASE. 5. Re-assemble the vapor poppet, spring and brass/stainless steel spider in the reverse order from which they were removed. 6. Install the retainer ring and actuate the poppet by hand,
(Vapor Recovery Adaptor) continued next page)		

¹ These maintenance requirements shall not circumvent use of the manufacturer's installation and maintenance instructions. Maintenance contractors or owner/operators shall refer to the manufacturers complete installation and maintenance instructions found herein to ensure that all maintenance and torque requirements are met. Maintenance must be conducted within the interval specified from the date of installation and at least within the specified interval thereafter.

Summary of Maintenance Activities Required of the FFS Phase I Vapor Recovery System ¹ (continued)		
Component	Interval	Maintenance To Be Performed
Vapor Recovery Adaptor Phil-Tite SWV-101-B and SWV-101-SS (continued)		<p>making sure the assembly is secure and actuates properly.</p> <p>7. Using a very small screwdriver, Install a new ¼ inch flat seal (85039). Make sure the ¼ inch flat seal is seated against the sealing surface below the swivel adaptor threads.</p> <p>8. Reinstall the SWV-101-B or SWV-101-SS vapor swivel on the black spill container riser as described in the “Installation Instructions” and properly torque the swivel adaptor on the spill container riser between 50 and 75 ft. lbs.</p> <p>Important: Apply an even coating of silicone based spray or a light coating of anti-seize compound to the male threads of the spill container riser and/or the swivel adaptor female threads. This will reduce the friction between these threads during installation and aid in removal of the swivel adaptor at a later date.</p>
Tank Gauge Components Morrison Brothers 305 series Veeder-Root 312020-952 EBW 90037 E	Annual	<p>Visually inspect cap to see that it is not missing any seals and is properly installed.</p> <p>Whenever probe service is necessary, also inspect the service cap seal for damage and replace, if necessary, at that time.</p>

¹ These maintenance requirements shall not circumvent use of the manufacturer’s installation and maintenance instructions. Maintenance contractors or owner/operators shall refer to the manufacturers complete installation and maintenance instructions found herein to ensure that all maintenance and torque requirements are met. Maintenance must be conducted within the interval specified from the date of installation and at least within the specified interval thereafter.

Summary of Maintenance Activities Required of the FFS Phase I Vapor Recovery System ¹ (continued)		
Component	Interval	Maintenance To Be Performed
Spill Container Lid Phil-Tite 85011	Monthly	<p>NOTE: DO NOT USE ANY PETROLEUM PRODUCTS ON THE WIPER SEAL, CAST IRON LID, OR THE STAINLESS STEEL SLEEVE.</p> <ul style="list-style-type: none"> • Clean the wiper seal using a clean rag and silicone spray. The Wiper Seal must be free of any dirt, dust and/or film build up. If unable to properly clean, replace the wiper seal (SC-1513V).
	Monthly	<p>Check the Wiper Seal for Flexibility:</p> <ol style="list-style-type: none"> 1. Place your thumbs on the outer surface of the seal approximately 4-6 inches apart. Push your thumbs toward each other. The wiper seal should have some movement between your thumbs. If there is no movement or flexibility, the wiper seal must be replaced and/or removed, cleaned, and rechecked. 2. Remove the wiper seal and clean the groove in the cast iron lid of any dirt or dust build up by using a clean rag and silicone spray. The use of a blunt tool may be required to remove any build up. 3. Clean all surfaces of the wiper seal using a clean rag and silicone spray. Any dirt or dust build up in the "U" section of the seal must be removed. The use of a wooden or plastic tipped instrument along with silicone spray may be required. If unable to properly clean, replace the wiper seal (SC-1513V). <p>Installing the Wiper Seal (SC-1513V) into the Groove of the Cast Iron Lid</p> <ol style="list-style-type: none"> 1. Install the wiper seal in the cast iron lid groove with the small (wiper) bulge facing outward and pointing upwards. Check the circumference of the installed seal for any twists or incorrect alignment of the seal in the groove.
(Spill Container Lid continued next page)		

¹ These maintenance requirements shall not circumvent use of the manufacturer's installation and maintenance instructions. Maintenance contractors or owner/operators shall refer to the manufacturers complete installation and maintenance instructions found herein to ensure that all maintenance and torque requirements are met. Maintenance must be conducted within the interval specified from the date of installation and at least within the specified interval thereafter..

Summary of Maintenance Activities Required of the FFS Phase I Vapor Recovery System ¹ (continued)		
Component	Interval	Maintenance To Be Performed
Spill Container Lid Phil-Tite 85011	Monthly	<p>Check the Stainless Steel Sleeve for Cleanliness</p> <ol style="list-style-type: none"> 1. Clean the area of the stainless steel sleeve where the wiper seal makes contact with the sleeve. Using a clean rag and silicone spray, wipe this area free of any dirt, dust and/or film build up. <p>Reinsert the Lid with Wiper Seal over the Spill Container and into the Stainless Steel Sleeve.</p> <p><i>Note: To ease installation use <u>silicone spray on the exposed surface of the wiper seal and on the lip of the stainless steel sleeve where the wiper seal makes contact. Do not use any petroleum products.</u></i></p> <ul style="list-style-type: none"> • Push down on the cast iron lid until it seats into the stainless steel sleeve. • Hold the cast iron lid until it seats into the stainless steel sleeve. • If the cast iron lid does not stay seated, wait five (5) seconds then push down on the cast iron lid again. You will feel the cast iron lid go down and seat into the stainless steel sleeve. • Repeat this process until the cast iron lid stays seated in the stainless steel sleeve.
EBW/Defender Lids 7054401X		<ul style="list-style-type: none"> • Wipe lid seal and spill container sealing surface with a rag to remove any dirt/debris. • Inspect the lid seal for any damage and replace if necessary. • Inspect the spill container sealing surface for any damage and replace if necessary. • • • (End of maintenance table.)

These maintenance requirements shall not circumvent use of the manufacturer’s installation and maintenance instructions. Maintenance contractors or owner/operators shall refer to the manufacturers complete installation and maintenance instructions found herein to ensure that all maintenance and torque requirements are met. Maintenance must be conducted within the interval specified from the date of installation and at least within the specified interval thereafter

**Franklin Fueling Systems
Phase I EVR Equipment Installation Check List
Installing Components per ARB Executive Order VR-101**

Date: _____

Site Location:(name) _____ Installing Contractor:(name

Address _____ Address

City/State

City/State _____

Contact/Phone _____ Contact/Phone

Tank Number: _____ Product: _____ Capacity: _____

Yes/No	Initials

Tank Number: _____ Product: _____

Capacity: _____

Tank Number: _____ Product: _____

Capacity: _____

Installing Technician: (name): _____

Technician Certification Number: _____ Signature: _____

1. Is all of the installed equipment for Phase I EVR listed in ARB Executive Order (E.O.) VR-101-O?

Note: All Phase I installed equipment must be listed in E.O. VR-101-O. See attached Exhibit 1 Listing Checklist, and mark/check off each item installed.

Yes/No	Initials

2. Have all tank risers been cut to the correct lengths and correctly installed into the tank bungs using an approved pipe dope?

Yes/No	Initials

3. For sites equipped with Phil-Tite series spill containers, and Defender Series spill containers with straight (NPSM) threads, do all tank risers that have a gasket/seal cap and/or spill containers have an M/F 4X4 Riser Adaptor installed?

Yes/No	Initials

a. Are all M/F 4X4 Riser Adaptors installed onto tank risers using approved pipe dope and torque to _____ ft. lbs.?

Yes/No	Initials

4. If a mechanical overfill prevention drop tube is installed, has the sealant (epoxy) been allowed to cure a minimum of 4 hours before installation? (EBW 70849X-1Y & 70849X-3Yonly)

5. For sites equipped with Phil-Tite series spill containers, on the fill

riser – Is the Drop Tube installed (under the spill container) using Phil-Tite Special 'O' Ring (85039-DT) with the flared end on top of the M/F 4X4 Riser Adaptor?

6. For sites equipped with Defender spill containers, on the fill riser, is the Drop Tube installed inside the spill container and under the Drop Tube Riser Clamp.

Note: EBW 70849X1Y and EBW 70849X-3Y drop tubes with mechanical overfill prevention valves must be cut to the correct length and the upper end flared using Flaring Tool T-6100-FT before installing into the tank riser.

**Franklin Fueling Systems
Phase I EVR Equipment Installation Check List (con't.)
Installing Products per ARB Executive Order VR-101-O**

Yes/No	Initials
--------	----------

7. For sites equipped with Phil-Tite series spill containers, are they installed onto the M/F 4X4 riser adaptors using approved anti- seize compound or silicone spray and torque to _____ ft. lbs.?

Yes/No	Initials
--------	----------

8. Are the Fill and Vapor Swivel Adaptors installed onto the spill container risers using an approved anti-seizing compound or spray silicone and torque to _____ ft. lbs.?

Yes/No	Initials
--------	----------

8. Pressure Vacuum Vent Valve – Is there a P/V Vent valve installed on the top of each (Gas or Gas/E85) vent pipe (a maximum of three EVR P/V valves per GDF) or manifold?

Yes/No	Initials
--------	----------

a. P/V vent valve(s) torque to _____ ft. lbs.

Yes/No	Initials
--------	----------

9. Tank Gauge Port Cap and Adaptor – If installed,

Yes/No	Initials
--------	----------

a. Has an M/F 4X4 Riser Adaptor been installed onto the tank gauge riser using an approved pipe dope and torque to _____ ft. lbs.

Yes/No	Initials
--------	----------

b. Is the Tank Gauge Adaptor installed onto the M/F/ 4X4 riser adaptor using an approved anti-seize compound and torque to _____ ft. lbs.?

FFS Phase I Vapor Recovery System Exhibit 1 Equipment Checklist

On line below, write out what configuration you used. Follow the legend below for each series spill container.

Configuration used: _____

(Gas/E85) = Identifies equipment approved for use with standard gasoline fuel blends and E85

(Gas) = Identifies equipment approved for use only with standard gasoline fuel blends

Equipment
Spill Container
(Phil-Tite Series)

Manufacturer/Model Number
 Phil-Tite 85100-1 and 85100 Series (Gas/E85)
 (Replacement only for existing installations)

8510X-1 and 8510X legend:

X represented by:

0 = product spill container

0-EXT = product spill container w extension collar

1 = vapor spill container

1-EXT = vapor spill container w extension collar

Spill Container
(Defender Series)

EBW Defender 705 Series* (Gas/E85)

Defender 705 Series Legend* (Gas/E85)

7055XYZAB where XYZAB is represented by:

X = containment

4 = single wall

5 = double wall

Y = installation

2 = multiport bucket

5 = direct bury

Z = interstitial monitoring method

0 = no sensor/gauge (i.e. single wall)

1 = I2 monitor (float gauge, visual)

2 = TSP-ULS (electronic sensor)

A = spill container base thread**

0 = NPSM (straight thread)

1 = NPT (taper thread)

B = drain valve

1 = with drain valve (typical on product/fill side)

2 = without drain valve (typical on vapor side)

EBW Series

EBW 7XX49Y0Z
 EBW Series Legend

XX indicates spill bucket size:

05 = 5 gallon

15 = 15 gallon

Equipment

Manufacturer/Model Number

Y indicates level:

0 = grade level with cast iron base (5 gal only)

2 = below grade level with cast iron base (5 & 15 gal)

Z indicates drain valve:

1 = drain valve

2 = no drain valve

*May be installed in direct bury or multi-port configurations including single fill or double tank riser orientations.

**NPSM base thread spill containers (straight thread) are designed for use with the Phil-Tite M/F 4X4 Riser Adaptor at sites where the NPT threads of the tank riser are not cut flat or square. NPT base spill containers (taper thread) do not require use of Phil Tite M/F Riser Adaptor at sites where the NPT threads of the tank riser are flat and cut square.

**Spill Container Lid
(Phil-Tite Series Spill
Containers)**

Phil-Tite 85011 (Gas/E85)

**Spill Container Lid
(Defender and EBW
Series)**

EBW 7054401X (Gas/E85)

X = Lid Color

**Replacement
Drain Valve
(Phil-Tite Series
Spill Containers)**

Phil-Tite 85400 (Gas/E85)

**Replacement
Drain Valve
(Defender Series Spill
Containers)**

EBW 70533729 (Gas/E85)

**Replacement
Drain Valve (EBW
Series Spill Container)**

EBW 70533719 (Gas)

**Drain Valve Blank Kit
EBW Series Spill
Container**

EBW 90022

**Drain Valve Blank Kit
(Defender Series Spill
Container)**

EBW 9002201

**Drain Valve Isolation
Kit (EBW Series Spill
Containers)**

EBW 70825501

**Drain Valve Isolation
Test Kit (EBW Series
Spill Containers)**

EBW 90079

<u>Equipment</u>	<u>Manufacturer/Model Number</u>
Product Adaptor	Phil-Tite SWF-100-B (Gas)
	Phil-Tite SWF-100-SS (Gas/E85)
Vapor Adaptor	Phil-Tite SWV-101-B (Gas)
	Phil-Tite SWV-101-SS (Gas/E85)
Riser Adaptor	Phil-Tite M/F 4X4* (Gas/E85)
	Phil-Tite M/F 4X4-R* (Gas/E85)
Riser Support Bracket	Phil Tite M 1600 (Gas/E85)
Drop Tube Riser Clamp (Defender Series Spill Containers)	FFS 70550901EC (Gas/E85)
Dust Cap	Morrison Brothers 323C-0100ACEVR (vapor) (Gas/E85)
	Morrison Brothers 305C-0100ACEVR (product)(Gas/E85)
	OPW 1711T-EVR (vapor) (Gas/E85)
	OPW 634TT-EVR (product) (Gas/E85)
	OPW 634LPC (product) (Gas)
	OPW 1711LPC (vapor) (Gas)
	CompXCSP1-634LPC (product) (Gas)
	CompXCSP3-1711LPC (vapor) (Gas)
	CompXCSP2-634LPC (product) (Gas)
	CompXCSP4-1711LPC (vapor) (Gas)
	EBW 77720102 (product) (Gas/E85)
	EBW 77720202 (product) (Gas/E85)
	EBW 30420006 (vapor) (Gas/E85)
	EBW 30430103 (vapor) (Gas/E85)
	Pressure/Vacuum Vent Valve
Husky 5885 (Gas)	
OPW 723V (Gas)	
Tank Gauge Port Components	Veeder-Root 312020-952 (cap and adaptor kit) (Gas/E85)
	Morrison Brothers 305XPA1100AKEVR (cap and adaptor kit) (Gas/E85)
	Morrison Brothers 305-0200AAEVR (replacement adaptor) (Gas/E85)
	Morrison Brothers 305XP-110ACEVR (replacement cap) (Gas/E85)
	EBW 90037-E (In Tank Probe Cap and Adapter Kit) (Gas/E85)
Drop Tube Overfill Prevention Device¹	Defender Series OPV 70859X9YZ (Gas/E85)
	Defender Series OPV legend

X = upper drop tube length:

1 = 5 feet

2 = 10 feet

Y = Tube compatibility:

Equipment

Manufacturer/Model Number

0 = Gas

2 = Gas/E85

Z = lower drop tube length:

1 = 8 feet

2 = 10 feet

EBW 70849X1Y (Gas)

EBW 70849X3Y (Gas/E85)

X represented by:

1 = 5 foot length upper drop tube section

2 = 10 foot length upper drop tube section

Y represented by:

1 = 8 foot length bottom thread on section drop tube

2 = 10 foot length bottom thread on section drop tube

Drop Tube¹

OPW 61-T (various lengths) (Gas)

EBW 7822041X-2 (X = various lengths) (Gas)

EBW 7822043X-2 (X = various lengths) (Gas/E85)

Riser Offset¹

Phil-Tite M-6050-X (x = various offsets) (Gas/E85)

**Double Fill¹
Tank Riser
Configuration**

Phil Tite (configuration only) (Gas/E85)

Defender (configuration only) (Gas/E85)

**Tank Bottom
Protector¹**

Phil-Tite TBP-3516-E (Gas/E85)

Fuel Lock¹

McGard FL1 – Stick Only Fuel Lock (125007) (Gas)

McGard FL2 – Stick/Sampling Fuel Lock (125008) (Gas)

Bladder Plug

McGard PSI104 (Gas)

¹ If these components are installed or required by regulations of other agencies, only those components and model numbers specified above shall be installed or used.

NOTE:

(Gas/E85) = Identifies that these components are approved for standard gasoline and E85 fuel blends.

(Gas) = Identifies that these components are only approved for standard gasoline fuel blends.

Table 1
Components Exempt from Identification Requirements

Component Name	Manufacturer	Model Number
Drop Tube	OPW EBW EBW	61-T Straight Drop Tube (Gas) 7822041X-2 (X = various lengths) (Gas) 7822043X-2 (X = various lengths) (Gas)
Dust Caps	Morrison Brothers	323C-0100ACEVR (vapor)* (Gas/E85) 305C-0100ACEVR (product)* (Gas/E85)
Tank Gauge Port Components	Veeder-Root	312020-952 (cap & adaptor) (Gas/E85)
	Morrison Brothers	305XPA1100AKEVR (cap and adaptor kit) (Gas/E85) 305-0200AAEVR (replacement adaptor) (Gas/E85) 305XP-1100ACEVR (replacement cap) (Gas/E85)
	EBW	90037-E (In Tank Probe Cap and Adaptor Kit) (Gas/E85)
Riser Adaptor	Phil-Tite	M/F 4X4 (Gas/E85) M/F 4X4-R (Gas/E85)
Riser Offset	Phil-Tite	M-6050-X (X = various offsets) (Gas/E85)
Riser Support Bracket	Phil-Tite	M-1600 (Gas/E85)
Spill Container Lid	Phil-Tite EBW	85011 (Gas/E85) 7054401X (Gas/E85)
Sump/Sump Lids	Varies	Varies (Gas/E85)
Drop Tube Riser Clamp	FFS	70550901EC (Gas/E85)
Replacement Drain Valve	EBW	EBW 70533729 EBW 70533719
Fuel Lock	McGard	FL1, FL2

* Morrison Brothers dust caps identified as 323C EVR and 305C EVR respectively.

Torque Values for Phil-Tite 85000-1 Series Spill Containers¹

PHASE I EVR TORQUE SETTINGS

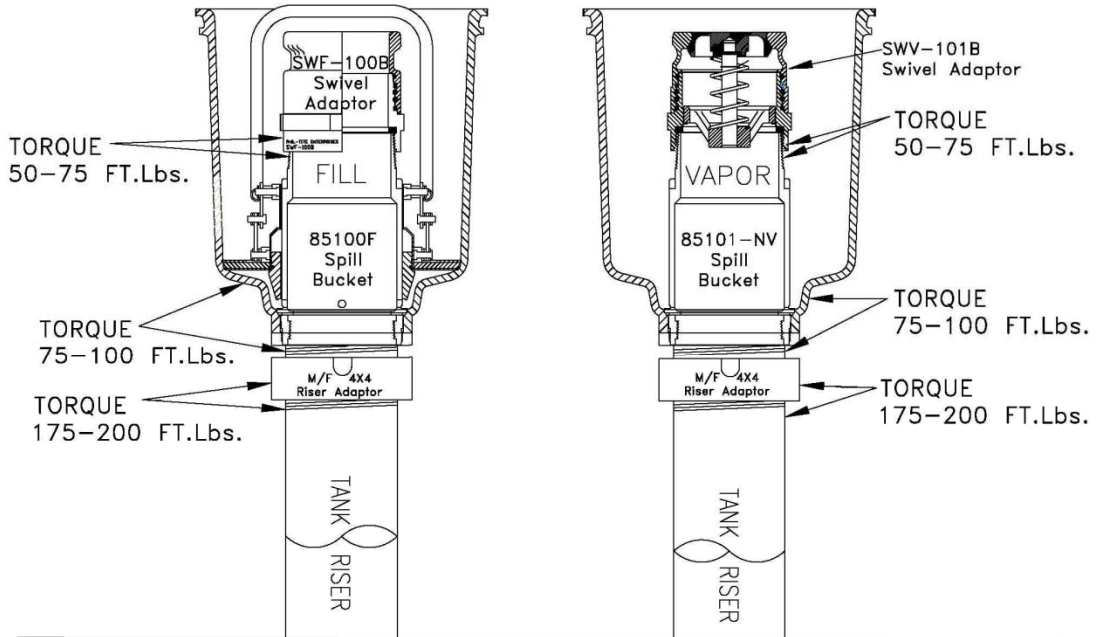

PHIL-TITE ENTERPRISES

Torque Values for EBW Defender Series Spill Containers (705 Series)

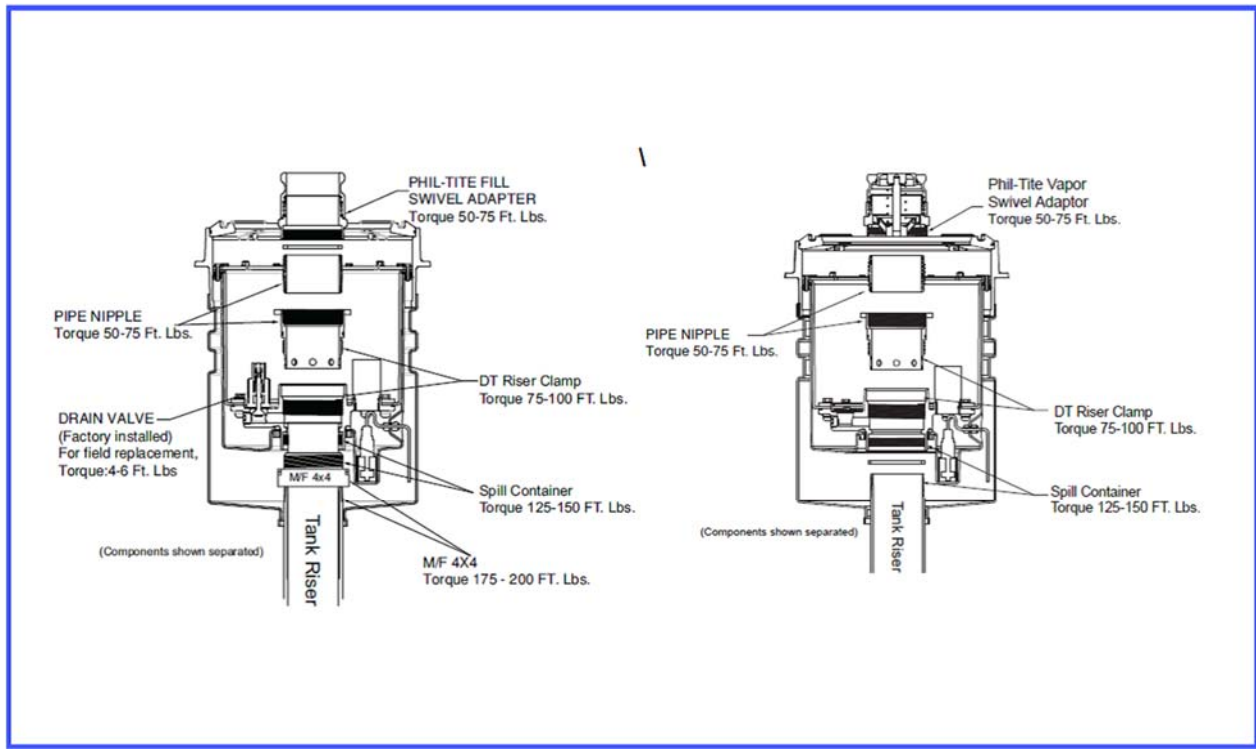

See applicable installation instructions for further information regarding the use of riser adaptors with EBW Defender Series spill containers. Riser adaptor is only required with spill container base cut with straight threads.

**FFS Phase I Vapor Recovery System
Installation, Operation and Maintenance Manual**

Table of Contents

<u>Equipment</u>	<u>Manufacturer/Model Number</u>	<u>Figure</u>	<u>Page</u>
Summary of Maintenance Activities Required of the			
FFS Phase I Vapor Recovery System			2
Installation Check List			10
Exhibit 1 Equipment Checklist			13
Components Exempt from Identification Requirements			17
Torque Values for Phil-Tite 85000-1 Series Spill Containers			18
Torque Values for Defender 705 Series Spill Containers			19
Table of Contents			20
Typical Installation (Product) with EBW Autolimiter II® 708-49X-1Y or Defender 70859X9YZ		A-1	23
Typical Vapor Recovery Side Installation Vapor Using Phil-Tite System		A-2	24
Phil-Tite 85000-1 Series Spill Container Installation Instructions		B-1	25
Spill Collector 5 Gallon Capacity and Height Spacer Instruction		B-2	33
Phil-Tite 85000-EXT Series Spill Container Installation Guide		B-3	34
Phil-Tite 85011 Cast Iron Spill Container Lid		B-4	41
Product Adaptor			
Phil-Tite SWF-100-series Installation Instructions		C-1	43
Phil-Tite SWF-100-series Maintenance Instructions		C-1	43
Vapor Adaptor			
Phil-Tite SWV-101-series Installation Instructions		C-2	44
Phil-Tite SWV-101-series Maintenance Instructions.....		C-2	44
Riser Adaptor			
Phil-Tite M/F 4X4 and M/F 4X4R Installation Instructions.....		D-1	45
Diagram of M/F 4x4 for use with 85000-1 Series Spill Container		D-2	46

Dust Caps

Morrison Brothers 323C-0100ACEVR (vapor).....	E-1	47
Morrison Brothers 305C-0100ACEVR (product).....	E-1	47
OPW 1711T-EVR (vapor).....	E-2	48
OPW 634TT-EVR (product).....	E-2	48
EBW 30420006 or 30430103 (vapor).....	E-3	49
EBW 77720102 or 77720202 (product).....	E-3	49
OPW 634LPC (product).....	E-4	50
OPW 1711LPC (vapor).....	E-4	50
CompX CSP1-634LPC or CSP3-634LPC (product).....	E-5	51
CompX CSP2-1711LPC or CSP4-1711LPC (vapor).....	E-5	51

Pressure/Vacuum Vent Valve

FFS PV-Zero.....	F-1	53
Husky 5885.....	F-2	65
VST 723V.....	F-3	68

Tank Gauge Port Components

Veeder-Root 312020-952 (cap & adaptor).....	G-1	72
Morrison Brothers 305XPA1100AKEVR (cap and adaptor kit).....	G-2	73
Morrison Brothers 305-0200AAEVR (replacement adaptor).....	G-2	73
Morrison Brothers 305XP-110ACEVR (replacement cap).....	G-2	73
EBW 90037-E In-Tank Probe Cap and Adaptor Kit.....	G-3	74

Drop Tube¹

OPW 61-T Straight Drop Tube.....	H-1	75
EBW 782 Straight Drop Tube.....	H-2	76

Drop Tube Overfill Prevention Device¹

EBW Autolimiter II® 708-49X- series.....	I-1	77
Phil-Tite Spill Container Measurement Work Sheet to Determine the Drop Tube Lengths for EBW Autolimiter II® 708-49X- series.....		80
Defender 708-59X-9YZ.....		88
Defender Spill Container Measurement Work Sheet to Determine the Drop Tube Lengths for EBW Autolimiter II 708-49X-a series.....		91

Tank Bottom Protector

Phil-Tite TBP-3516 series.....	J-1	99
--------------------------------	-----	----

Riser Offset¹

Phil-Tite M-6050 Examples.....	K-1	100
--------------------------------	-----	-----

Riser Support Bracket

Phil-Tite M-1600.....	K-2	101
-----------------------	-----	-----

Double Fill¹

Phil-Tite (configuration only).....	L-1	104
Defender Series (configuration only)		

FFS/Phil-Tite Phase I Installation & Removal Tool Kit

T-7043 / T-7043-1	L-2.....	105
Figure of T-7043 Toolkit.....	L-3.....	106
Defender Series Spill Container: Single Wall Configuration		
Installation, Operation, and Maintenance Instructions	M-1	107
Defender Series Spill Container: Double Wall Configuration		
Installation, Operation, and Maintenance Instructions	M-2.....	118
Defender Series Spill Container: Single Wall Fiberglass Configuration		
Installation, Operation, and Maintenance Instructions	M-3.....	130
Defender Series Spill Container: Multiport New		
Installation, Operation, and Maintenance Instructions	M-4.....	138
Defender Series Spill Container: Multiport Retrofit		
Installation, Operation, and Maintenance Instructions	M-5.....	150
EBW Spill Container Manholes: Below Grade		
Installation, Operation, and Maintenance Instructions	M-6.....	158
EBW Spill Container Manholes: Grade Level		
Installation, Operation, and Maintenance Instructions	M-7	166
EBW Drain Valve (for use with Defender Series)		
Installation, Operation, and Maintenance Instructions	M-8.....	174
Defender Series Typical Product Side Installation		
Single Wall Direct Bury Configuration	N-1	175
Defender Series Typical Product Side Installation		
Double Wall Direct Bury Configuration with I2 Monitor	N-2	176
Defender Series Typical Product Side Installation		
Double Wall Direct Bury Configuration with TSP-ULS Liquid Sensor..	N-3	177
Defender Series Typical Vapor Side Installation		
Single Wall Direct Bury Configuration	N-4	178
Defender Series Typical Vapor Side Installation		
Double Wall Direct Bury Configuration with I2 Monitor	N-5	179
Defender Series Typical Vapor Side Installation		
Double Wall Direct Bury Configuration with TSP-ULS Liquid Sensor..	N-6	180
McGard Fuel Lock.....	O-1	181

Figure A-1
Typical Product Side Installation of Phil-Tite System Using
FFS Autolimiter II® 708-49X- Series or Defender 70859X9YZ series OPV

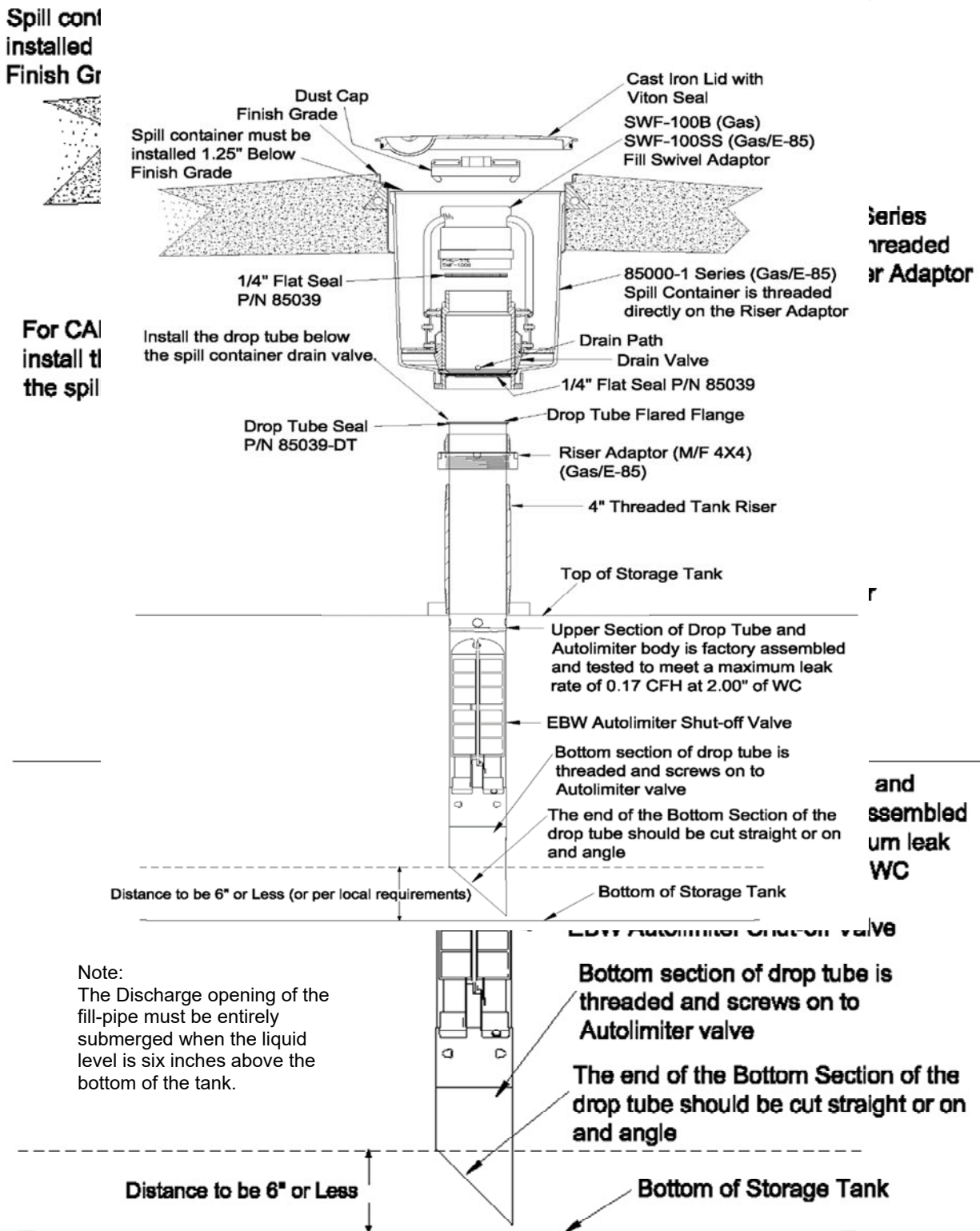

Figure A-2
Typical Vapor Recovery Side Installation Using Phil-Tite System

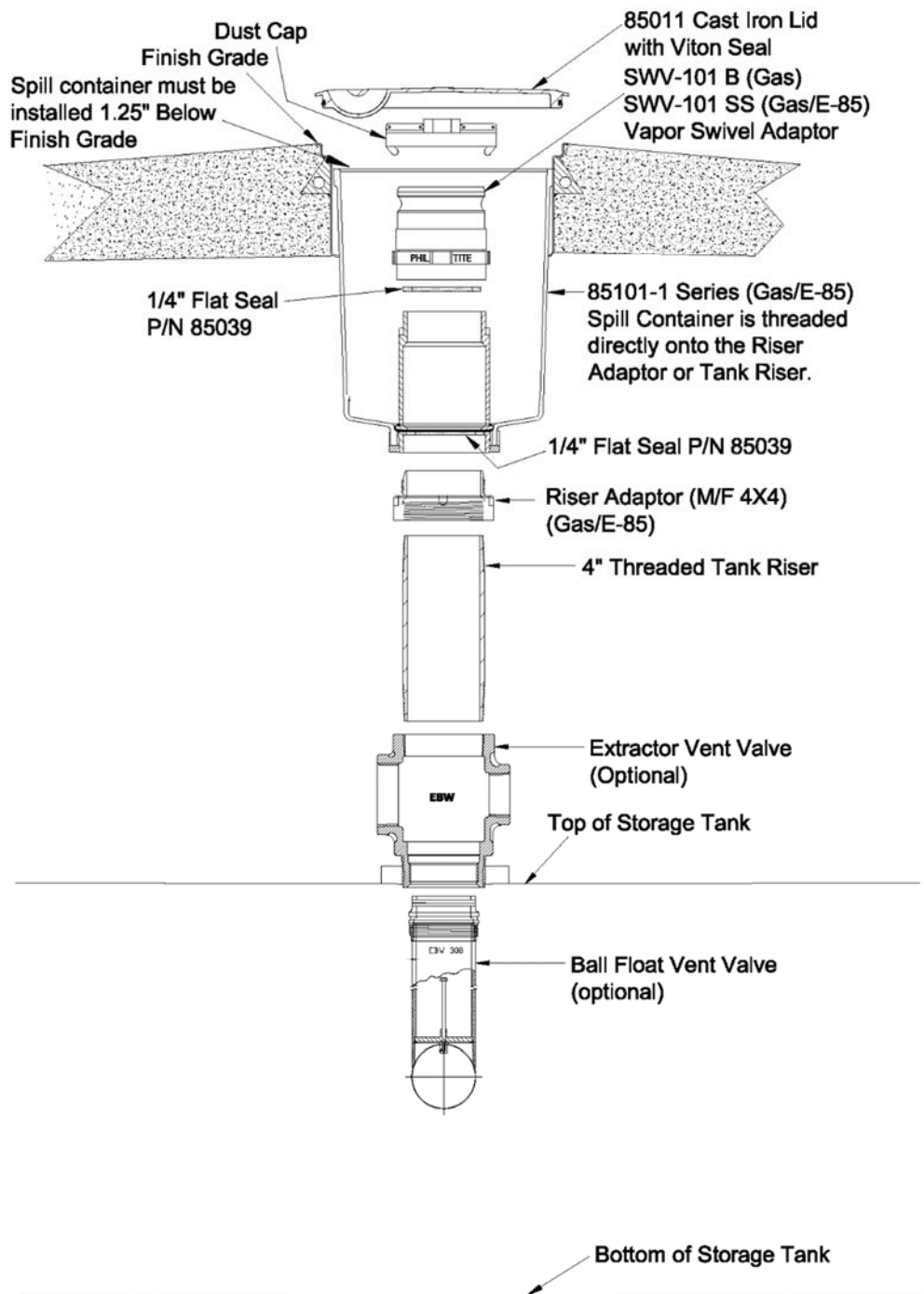

Figure-B1

PHIL-TITE

Franklin Fueling Systems

85000-1 Series Spill Containers – Fill and Vapor Installation Instructions

Introduction

Phil Tite Spill Containers (Fill and Vapor) are designed to provide easy installation and/or removal of the spill container without the need for timely excavation, cutting concrete or disassembly of secondary containment covers. Phil-Tite's drain valves drain directly into the tank, providing a fast and complete removal of excess liquid spilled during a product delivery operation while maintaining a reliable seal that is vapor and liquid tight, eliminating leaks into the environment. All Phil-Tite's Spill Containers have straight machined threads (female threads where the spill container screws onto the riser adaptor.) All Spill Containers are shipped completely assembled and CARB Phase I EVR Tested and Certified. No field assembly is required. The new 85000-1 Series Spill Container can be used as a direct replacement for a correctly installed 85000 series EVR Spill Container without cutting concrete or changing the tank riser. *Note: On EVR certified systems the drop tube is installed under the fill spill container.*

INSTALLATION:

For New UST Installation and/or UST's being Upgraded

Step 1 – Determining The Correct Riser Length for Spill Container Installation

1. Method 1 - Cut and thread your steel tank riser to allow approximately **18 1/8"** (Fill riser), and/or **18"** (Vapor riser) from top of the tank riser to finish grade. This measurement assumes an M/F 4X4 Riser Adaptor will be installed. Also this measurement will allow the water tight cast iron lid to seat properly into the stainless steel sleeve when the spill container is installed. See Figure 1.
2. Method 2 - With the M/F 4X4 Riser Adaptor installed onto the Tank Riser you should have **16 3/8"** (Fill), and **16 1/4"** (Vapor) measured from the top of the M/F 4X4 riser adapt and/or to finish grade and/or top of the diamond plate manway cover. This measurement will allow the water tight cast iron lid to seat properly into the stainless steel sleeve. See Figure 1.
3. Method 3 - Using a tape measurer, measure from top of the tank to finish grade and/or top of the manway cover. This is measurement "A". For 85000-1 Fill Spill Container subtract **18 1/8"** from measurement "A" to equal **XXX"**. **"A" – 18 1/8" = xxx"**. For the 85000-1 vapor spill container subtract **18"** from "A". The results are the length of your risers measured from the top of the tank. Cut and thread one end of your 4" riser and dry fit it into the tank bung. Measure your riser (installed into the tank bung) from top of tank to the dimension above, mark your riser. Cut this riser on the mark made above and thread this end. See Figure 1.

Step 2 – Dry Fit All Components

- A. Dry fit your tank riser to verify your measurements. After you have dry fitted all components and are satisfied with your measurements, apply an approved fuel resistant, non hardening thread sealant (pipe dope) to the NPT threads on both ends of the tank risers.

Step 3 – Install Tank Risers

- A. Install and torque the tank risers into the tank bungs.

For Replacing Existing Phil-Tite 85000 series Spill Containers with 85000-1 series Spill Containers

Step 1 - Determining The Correct Tank Riser length for Spill Container Installation

- A. Existing tank risers with NO M/F 4X4 riser adaptor installed. – Using a tape measure, measure from the top of your riser to finish grade and/or top of the manway cover. Record this measurement. For Fill spill containers this measurement should be **18-1/8"** from the top of the riser to finish grade. For Vapor Spill Containers this measurement should be **18"** from top of riser to finish grade. If these measurements are less than the above measurements you must shorten your riser to meet these measurements. These measurements allow for an M/F 4X4 Riser Adaptor to be installed on top of the tank riser before the spill container is installed. If you are not installing an M/F 4X4, add **1-3/4"** to your riser length.

*Remember, from finish grade to the top of the M/F 4X4 adaptor installed on the riser should be **16-3/8"** for Fill spill containers. See Figure 1.*

- B. Existing tank risers with M/F 4X4 riser adaptor installed – Using a tape measurer, measure from the top of the M/F 4X4 riser adaptor to finish grade and/or to the top of the stainless steel sleeve. Record this measurement. For Fill Spill Containers this measure must be greater than or equal to **16-3/8"** (**16 3/8"** – **20 1/8"**), and for Vapor Spill Containers this measurement must be greater than or equal to **16 1/4"** (**16 1/4"** – **20"**).
- C. If your existing riser is to long, there are several possible ways you can shorten them. Some possible methods are:
 - 1) Remove the nipple that would have been installed prior to 2001 under the pre-EVR Installation Instructions and install a shorter nipple. Especially helpful for direct buried spill containers.
 - 2) For multi-port systems, remove the existing riser(s) and install the correct length riser(s). Use an M-1600 riser support bracket to maintain alignment 16" on center between the fill and vapor riser.
 - 3) For direct buried risers with no nipple and coupler you maybe able to excavate down to tank top using a 10" to 11" OD PVC pipe placed over the 4" riser. Then remove the backfill material as you lower the pipe down over the riser. When you have reached tank top remove the 4" riser and install the correct length 4" riser per following Steps 2 & 3. After you have installed the tank riser gradually remove the 10" – 11" OD PVC pipe as you back fill the space between the 4" riser and the 10 – 11" OD PVC pipe.

Step 2 - Dry fit your riser to verify your measurements.

- A. After you have dry fitted all components and are satisfied with your measurements, apply an approved fuel resistant, non hardening thread sealant (pipe dope) to the NPT threads on both ends of the tank risers.

Step 3 - Install the correct length tank risers

- A. Install and torque the 4" tank risers into the tank bungs.

85000-1 Series Spill Container Installation

Step 1 – Preparing the Black Spill Container for Installation

- A. Inspect the black spill containers ensuring that the ¼" flat seal is in place and properly oriented for sealing onto the flared top of the drop tube (Fill) or on the M/F 4X4 Riser Adaptor (vapor). On Fill spill containers ensure the drop tube has the special Phil-Tite "O" Ring (85039-DT) installed under the upper drop tube flare and is seated on top of and inside the M/F 4X4 riser adaptor installed on top of the tank riser. If you are using a straight drop tube from a different manufacturer, discard the "O" Ring that may have been shipped with this drop tube and use the special Phil-Tite "O" Ring (85039-DT) that is shipped with each Fill Spill Containers.
- B. 85000-1 Fill Only. Inspect the foam filter located inside the container. The filter should be lying flat and secured by the stainless steel snap ring. Move the drain valve handle back and forth making sure that the lower screen assembly rises (compresses) when moved to the open position and extends when closed. The drain valve handle should move freely with no binding and must snap into place when moved to the closed position.
- C. **ALL SPILL CONTAINERS - NOTE: DO NOT USE ANY TYPE OF THREAD SEALING COMPOUND (PIPE DOPE) FOR SPILL CONTAINERS INSTALLATION!** Apply an even coat of Anti-seize compound to the black spill container female threads and/or to the M/F 4X4 riser adaptor male threads or apply a light Silicon based spray. This will reduce the friction between these threads during installation and aid in removal of the spill containers at a later date.

Phil-Tite Spill Containers create an optimum, leak free seal when properly tightened (torque) to the M/F 4X4 riser adaptor.

When installing the black spill containers in a direct bury application apply an even coat of Silicon based spray to the large outer "O" Ring seal of the black spill container and to the inside of the stainless steel sleeve to ease insertion.

Note: For multi-port installations - Apply an even coat of Silicon based spray to the large outer "O" Ring seal of the black spill containers(s) and to the inside of the stainless steel sleeve(s) just prior to installing the manway cover with stainless steel sleeves. This will aid in installing the manway cover over the installed spill containers.

Step 2 - Installing the Black Spill Container onto the M/F 4X4 Riser Adaptor

- A. By hand, thread the black spill container onto the male threads of the M/F 4X4 riser adapter taking care not to cross thread the spill container riser. These threads are straight threads not NPT pipe threads. The spill container must screw down and seat on the top of the drop tube flare (Fill) or on the top of the M/F 4X4 riser adaptor sealing surface (Vapor).

Step 3 – Tightening the Spill Container

Using a ½” drive torque wrench and the Black tool adapter (T-7101 or T-7002, Black) from Phil-Tite T-7043 Tool Kit, tighten the Spill Container onto the M/F 4X4 Riser Adaptor threads to a torque value between **75 and 100 ft. lbs.**

Step 4 – Final Installation

Check the measurement from the top of the black spill container to the top of the stainless steel sleeve at finish grade. Ensure there is at least **1 1/4”** inches of clearance (more is OK) from the top of the black spill container to the top of the stainless steel sleeve at finish grade. This will allow for the water tight cast iron lid to fit properly and ensure that the spill container and tank riser are not in direct contact with the cast iron lid. This ensures the concrete with manway cover are not load bearing onto the tank fill and vapor risers.

Step 5 – Drain Valve Testing

Test the drain valve assembly as described in CARB procedure TP-201.1D.

Step 6 – After Spill Container Installation

The spill container is now ready for the installation of the rotatable (swivel) adaptor and dust cap. Install the fill and/or vapor swivel adaptor using the SWF-100B/SWV-101B Installation Instructions.

Figure 1

85000-1 EVR SPILL CONTAINER INSTALLATION GUIDE

For the Cast Iron Lid to seat properly the Black Spill Container must be a min. of 1 1/4" below the top of the stainless steel sleeve

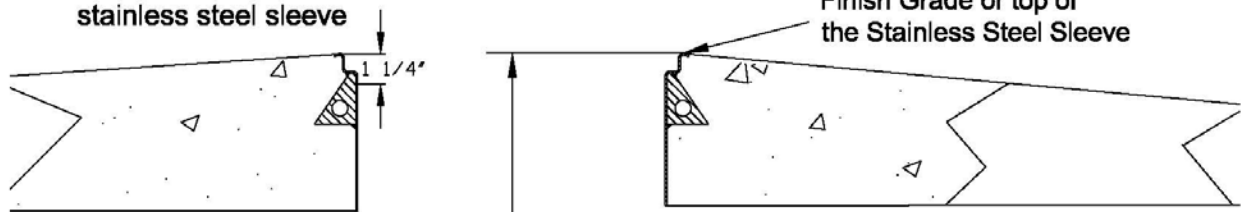

Allow Approximately 16 3/8" From the Top of The Riser Adaptor (M/F 4X4) To Finish Grade

Or allow 18 1/8" from top of tank riser to finish grade. This deminsion will allow for the M/F 4X4 Riser Adaptor and 85000-1 Spill Container to be correctly installed.

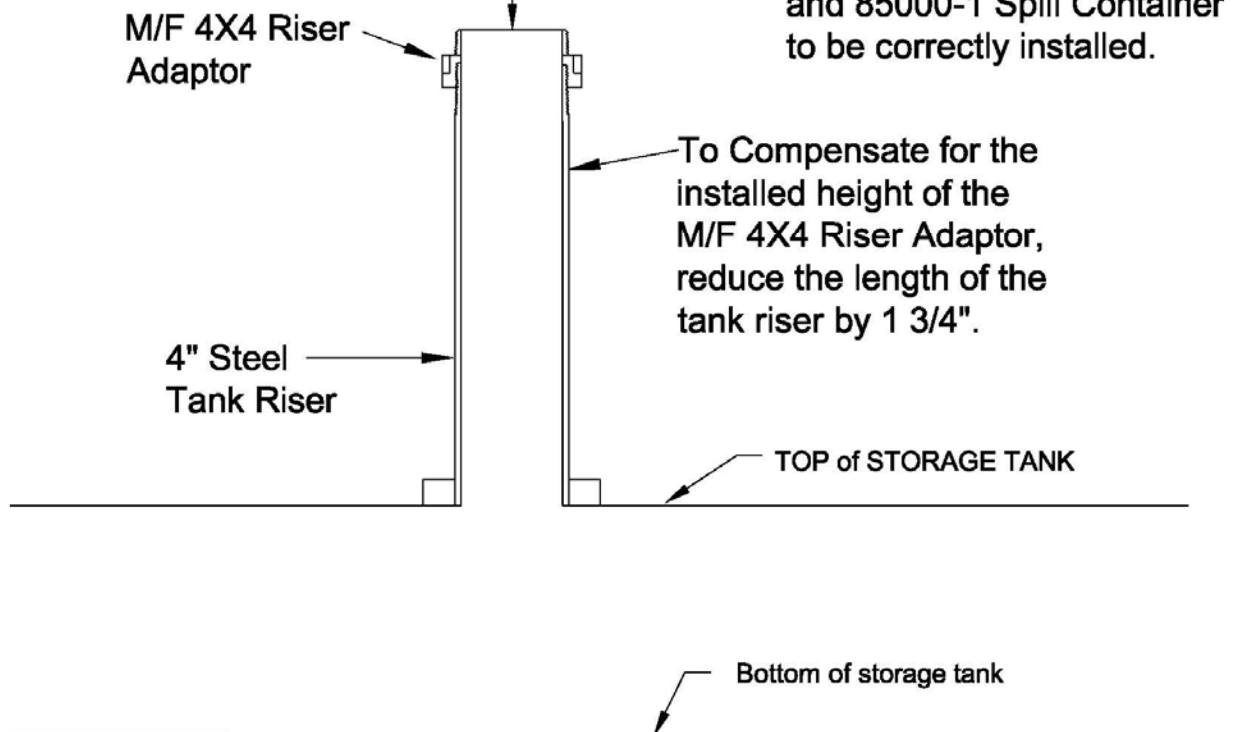

To Compensate for the installed height of the M/F 4X4 Riser Adaptor, reduce the length of the tank riser by 1 3/4".

Figure 2 (Direct Bury)
5 GALLON SPILL CONTAINER

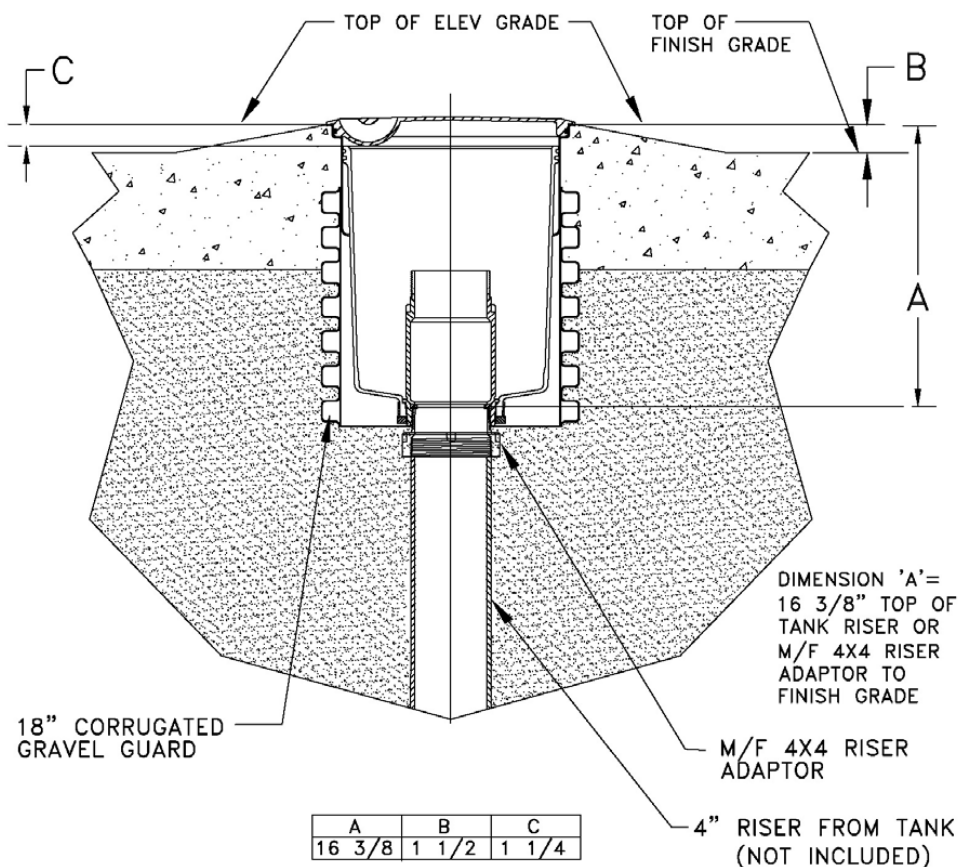

NOTES:

- 1- FOR VAPOR TIGHT INSTALLATION AND EVR APPLICATIONS USE AN M/F 4X4 RISER ADAPTOR ON ALL TANK RISERS (REDUCE THE LENGTH OF THE TANK RISER BY 1 3/4")
- 2- ALL DIMENSIONS SHOWN ARE SUGGESTED BY THE MANUFACTURER AND ARE APPROXIMATE. ACTUAL INSTALLATION CONDITIONS MAY VARY.

Unused Page



PHIL-TITE
Franklin Fueling Systems

3760 Marsh Road
Madison, WI 53718, U.S.A.
Tel: +1 608 838 8786
Tel: USA & Canada 1 800 225 9787
Tel: Mexico 001 800 738 7610
www.franklinfueling.com

Figure-B2**“Spill Collector 5 Gallon Capacity and Height Spacer”**

1. Insert the Styrofoam Spacer into the stainless steel sleeve on top of the Black Spill Bucket.



2. With the Styrofoam Spacer on top of the black spill bucket, the top of the spacer should be at or below the rim under the Cast Iron Lid. See Arrow in Photo.
3. During Construction, the Spacer should be left in place with the cast iron lid installed to provide the correct height with finish grade until concrete has been poured and set.

 **Franklin Fueling Systems**
www.franklinfueling.com
3760 Marsh Road • Madison, WI 53718, U.S.A.
Tel: +1 608 838 8786 • Fax: +1 608 838 6433
Tel: USA & Canada 1 800 225 9787 • Tel: México 001 800 738 7610

Figure-B3



85000-EXT Series Spill Containers Installation Instructions

Introduction

Many Gasoline Dispensing Facilities (GDF's) desire a single solid light weight manway cover over the location where the UST's fuel delivery/transfer spill and overflow protection equipment is installed inside a UST sump. This concept uses a single exterior cover to help keep water intrusion and dirt out and provide higher security in accessing the UST's. The manway covers that are used for this configuration are Composite manway covers that are removed by using a single tool without having to bend over. There are rain tight models and watertight models. The manway cover is removed (using a single point removal tool) to access the spill containers during bulk fuel deliveries. Below the manway cover is a fiberglass refueling platform that is installed either above the spill containers or under the spill containers and on top of the UST sump reducer/corbel. During bulk fuel transfers the driver removes the manway cover and connects the tanker truck fuel hoses with adaptors to the appropriate spill container while standing on the refueling platform. In the event of a spill during delivery, the spill container and the UST Sump are available to contain the spill.

Phil-Tite's 85000 EXT series 5 gallon capacity Spill Containers (Fill and Vapor) were designed for this type of application using one of three Phil-Tite fiberglass platforms designed for this application. These spill containers and fiberglass platforms were first certified and listed in ARB Executive Order VR-101-C dated September 16, 2003.

The components of the 85000-EXT (extended) series spill containers are the same as the 85000 series spill containers. A 3 X 15 inches diameter extension has been added to the 85000 series spill container in order for it to contain 5 gallons of liquid without the use of the stainless steel sleeve and is installed as a stand alone spill container without a cover. The Phil-Tite's drain valve drains liquid directly into the tank, providing a fast and complete removal of excess liquids spilled during a product delivery operation while maintaining a reliable seal that is vapor and liquid tight, eliminating leaks into the environment. Phil-Tite's Spill Containers have straight machined threads (female threads where the spill container screws onto the tank riser adaptor.) All Spill Containers are shipped completely assembled and ARB EVR Certified. No assembly is required. Note: On EVR certified systems, the drop tube is installed below the drain valve and under the fill spill container.

Figure B-5
Diagram of Measurements for 85000-EXT series installation

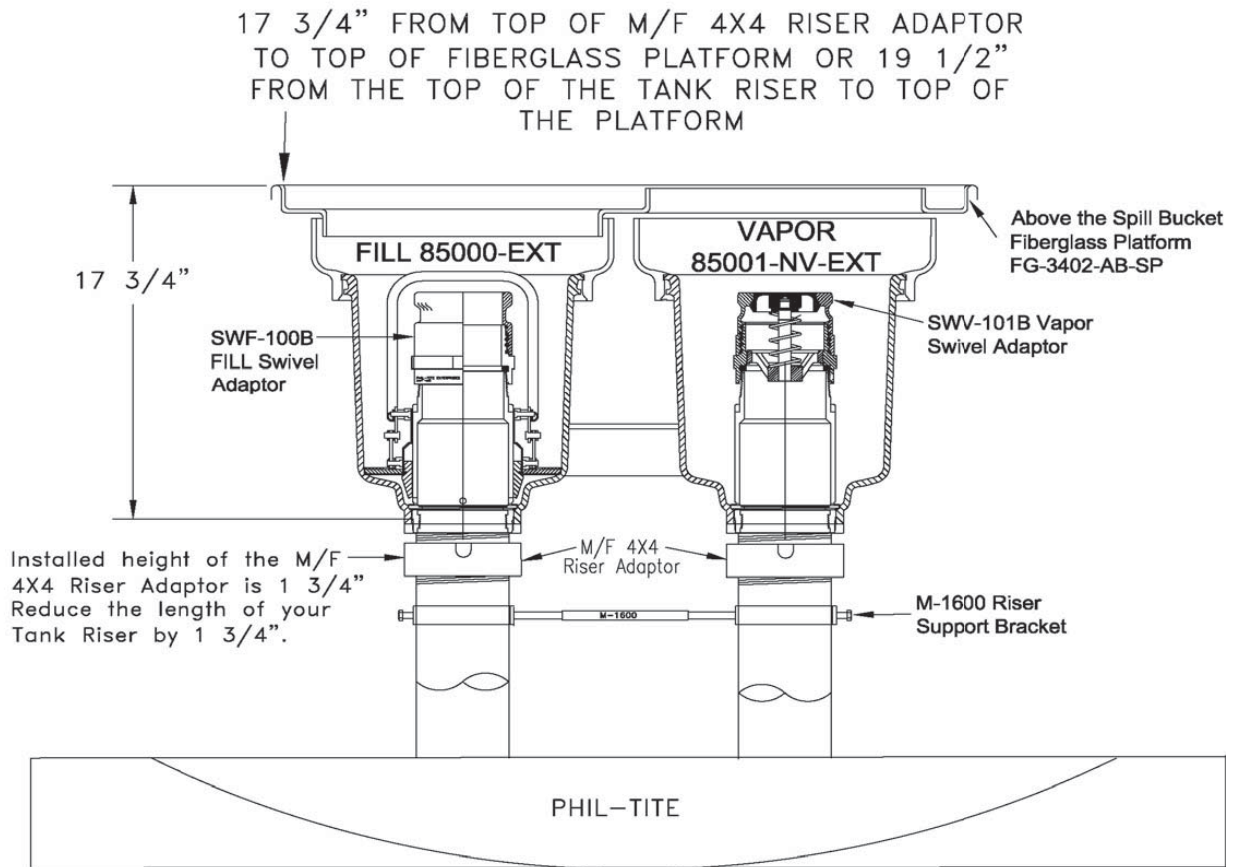

D. **Alternate Measuring Method 2** – Above the Spill Containers Platform – This Platform is installed just below (approx. 1 1/2 inches) the bottom of the composite manway cover. See Diagram of 'Typical Manway Cover Dimensions' for the dimensions for a typical 36 inch composite manway cover. From finish grade and/or top of lip in the manway cover frame to top of the corbel the fiberglass platform seats on should measure approximately 4 1/2 to 5 1/2 inches. (Continued on next page)

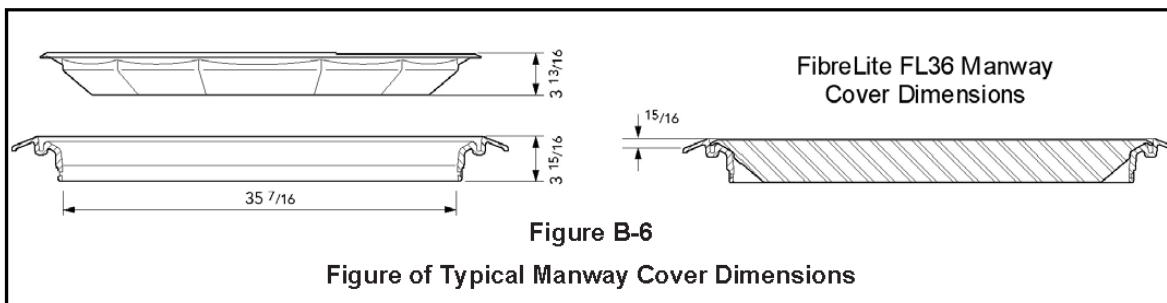

Step 2 – New Installation for an Above the Spill Containers Fiberglass Platform

- A. Using a tape measure, measure from top of the tank to finish grade. This is measurement “A”. Subtract 24 to 25 inches from measurement “A” to equal “XXX”. “A” – 24 inches = “XXX”. The result is the length of your riser measured from the top of the tank. Cut and thread one end of your 4 inch tank riser and dry fit it into the tank bung. Measure your riser (installed into the tank bung) from top of tank to the dimension found above, mark your risers. Cut your tank risers (fill & vapor) on the marks made above and thread this end.

Step 3 – Dry Fit All Components

Dry fit your riser to verify your measurements. After you have dry fit all components and are satisfied with your measurements, apply an approved fuel resistant, non hardening thread sealant (pipe dope) to the NPT threads on tank end of the risers.

Step 4 – Install Tank Risers

Install and torque the tank risers into the tank bungs.

Step 5 – Install the M-1600 Riser Support Bracket before you install the M/F 4X4 Riser Adaptors

Install the M-1600 Riser Support bracket between the two 4 inch (Fill and Vapor) tank risers just below the top of the tank riser threads for the M/F 4X4 riser adaptors. Tighten and/or set the turn buckles to maintain the space between the two tank risers at 16 inches on center.

Step 6 – Check your dimensions

With the M/F 4X4 riser adaptors and spill containers dry fitted, check the dimension from the top of the spill container to finish grade or top of composite manway cover. You should have 4 ½ to 5 inches clearance. Verify the height of the fiber glass platform. Check for 1 ½ inches of clearance between the top of the platform and the bottom of the composite manway cover.

Step 7 – Install the M/F 4X4 riser adaptors

Using the M/F 4X4 Riser Adaptor Installation Instructions install and torque the M/F 4X4 riser adaptors.

You are now ready to install the 85000-EXT Spill Containers. Refer to the 85000-EXT Series Spill Container Installation Instructions in this document.

Step 2 – Dry Fit All Components

Dry fit your riser to verify your measurements. After you have dry fit all components and are satisfied with your measurements, apply an approved fuel resistant, non hardening thread sealant (pipe dope) to the NPT threads on tank end of the risers.

Step 3 – Install Tank Risers

Install and torque the tank risers into the tank bungs per tank manufacture instructions.

Step 4 – Install the M-1600 Riser Support Bracket before you install the M/F 4X4 Riser Adaptors

Install the M-1600 Riser Support bracket between the two 4 inch (Fill and Vapor) tank risers just below the top of the tank riser threads for the M/F 4X4 riser adaptors. Tighten and/or set the turn buckles to maintain the space between the two tank risers at 16 inches on center.

Step 5 – Check your dimensions

With the M/F 4X4 riser adaptors and spill containers dry fitted, check the dimension from the top of the spill container to finish grade. You should have 4- ½ inches to 5 inch clearance. Verify the height of the fiberglass platform. Check for 1 -½ inches of clearance between the top of the platform and the bottom of the composite manway cover.

Step 6 - Install the M/F 4X4 riser adaptors

Using the M/F 4X4 Riser Adaptor Installation Instructions install and torque the M/F 4X4 riser adaptors.

Step 7 – Install the fiberglass platform before installing the 85000-EXT Spill Containers.

The Watertight Fiberglass Platform must be installed and latched down before the 85000-EXT Spill Containers can be installed.

You are now ready to install the 85000-EXT Spill Containers. Refer to the 85000-EXT Series Spill Container Installation Instructions on the following pages.

85000-EXT Series Spill Container Installation

Step 1 – Preparing the Black Spill Container for Installation

- A. Inspect the black spill container ensuring that the ¼ inch flat seal is in place and properly oriented for sealing onto the flared top of drop tube (Fill) or on the M/F 4X4 Riser Adaptor (vapor). On Fill spill containers ensure the drop tube has the special Phil-Tite seal (85039-DT) installed under the upper drop tube flare and is seated on top of and inside the M/F 4X4 riser adaptor installed on top of the tank riser. If you are using a straight drop tube from a different manufacturer, discard the "O"-Ring that may have been shipped with this drop tube and use the special Phil-Tite seal (85039-DT) that is shipped with each Fill Spill Container.
- B. 85000-EXT Fill Spill Containers. Inspect the foam filter located inside the container. The filter should be lying flat and secured by the stainless steel retainer ring. Move the drain valve handle back and forth making sure that the lower screen assembly rises (compresses) when moved to the open position and extends when closed. The drain valve handle should move freely with no binding and snap into place when moved to the closed position.
- C. NOTE DO NOT USE ANY TYPE OF THREAD SEALING COMPOUND (Pipe Dope) FOR SPILL CONTAINER INSTALLATION! Apply an even coat of Silicon based Spray or Lubrisilk Marine Boron CLS Bond Spray to the black spill container female threads and to the M/F 4X4 riser adaptor male threads or apply a light coating of anti-seize compound. This will reduce the friction between these threads during installation and aid in removal of the spill container at a later date.

Step 2 - Install the Black Spill Container onto the M/F 4X4 Riser Adaptor

By hand, thread the black spill container onto the male threads of the M/F 4X4 riser adapter, taking care not to cross thread the spill container riser threads. These threads are straight threads, not NPT pipe threads. The spill container must screw down and seat on the top of the drop tube flare (Fill) or on the top of the M/F 4X4 riser adaptor sealing surface (Vapor).

Step 3 – Tightening the Spill Containers

Using a ½ inch drive torque wrench and the special tool adapter (T-7101 or T-7002A, Black) from Phil-Tite Tool Kit (T-7043), tighten the Spill Container onto the M/F 4X4 Riser Adaptor threads to a torque value between **75 and 100 ft. lbs.**

Step 4 – Final Installation Check

Watertight Platform - ensure that the top of the spill containers are even with or just below the top of the platform and the watertight boots are installed (small end around the platform openings, large end around the spill container(s)). Check to insure that the watertight latches are closed.

Step 5 – Drain Valve Testing

Test the drain valve assembly as described in ARB test procedure TP-201.1D.

The spill container is now ready for the installation of the rotatable (swivel) adaptor and dust cap. Install the fill and/or vapor swivel adaptor using the SWF-100-B and SWV-101-B Installation Instructions. Torque the swivel adaptor to a value between **50 and 75 ft. lbs.**



PHIL-TITE
Franklin Fueling Systems

3760 Marsh Road
Madison, WI 53718, U.S.A.
Tel: +1 608 838 8786
Tel: USA & Canada 1 800 225 9787
Tel: Mexico 001 800 738 7610
www.frankinfueling.com

Figure B-4
Phil-Tite 85011 Spill Container Lid with Wiper Seal
(Installation and maintenance are on the following Page)

14" CAST LID (ONE OPENING)

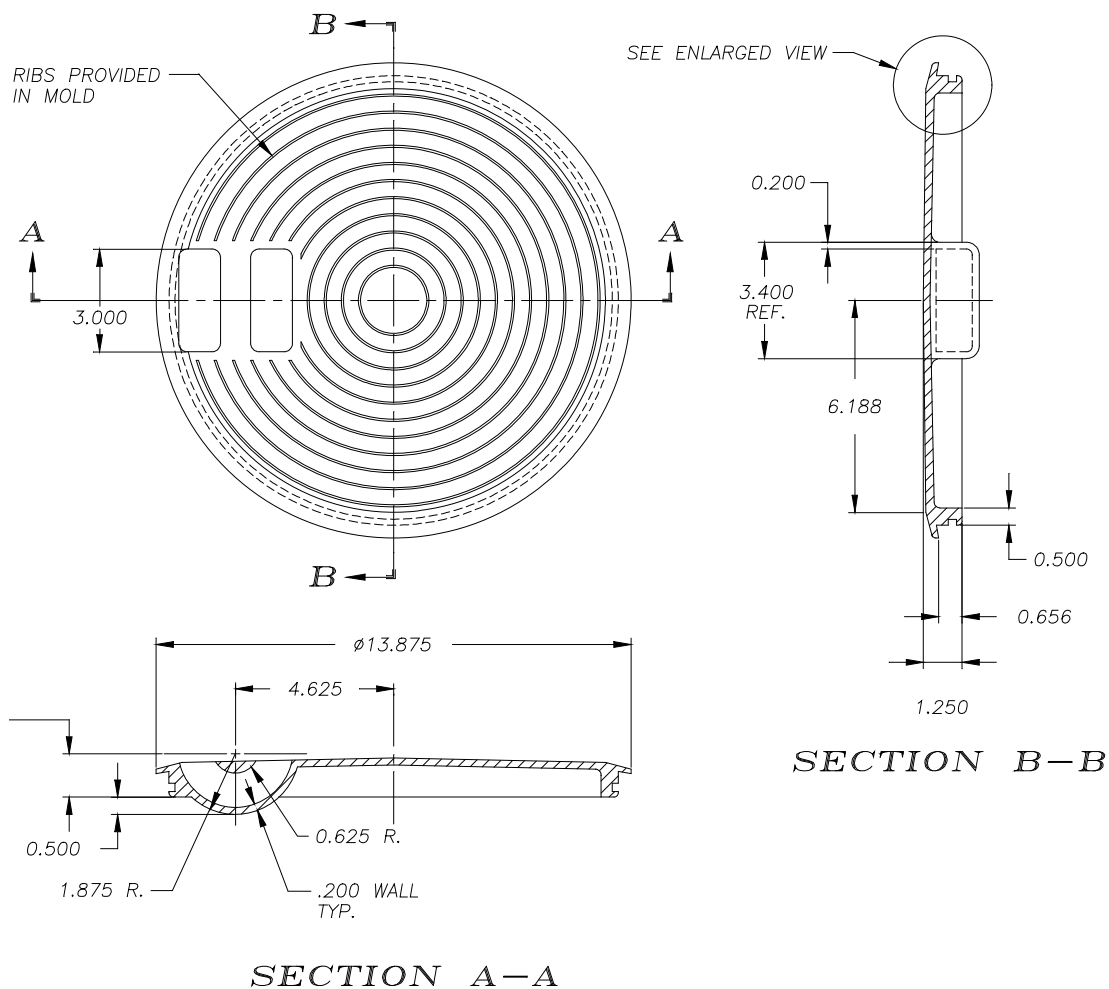

CAST IRON LID WITH WIPER SEAL - ROUTINE INSPECTION AND MAINTENANCE

PERIODICALLY INSPECT THE CAST IRON LID WIPER SEAL FOR WEAR, CUTS, TEARS, ABRASIONS AND SWELLING.

- If any discrepancies are noted replace the wiper seal (SC-1513V).

CHECK THE WIPER SEAL FOR CLEANLINESS

Note: DO NOT USE ANY PETROLEUM PRODUCTS ON THE WIPER SEAL, CAST IRON LID, OR THE STAINLESS STEEL SLEEVE.

- Clean the wiper seal using a clean rag and silicon spray. The Wiper Seal must be free of any dirt, dust and/or film build up. If unable to properly clean, replace the wiper seal (SC-1513V).

CHECK THE WIPER SEAL FOR FLEXIBILITY

- Place your thumbs on the outer surface of the seal approximately 4" – 6" apart. Push your thumbs toward each other. The wiper seal should have some movement between your thumbs. If there is no movement or flexibility the wiper seal must be replaced and/or removed, cleaned, and rechecked.
- Remove the wiper seal and clean the groove in the cast iron lid of any dirt or dust build up by using a clean rag and silicon spray. The use of a blunt tool may be required to remove any build up of dirt or dust.
- Clean all surfaces of the wiper seal using a clean rag and silicon spray. Any dirt or dust build up in the "U" section of the seal must be removed. The use of a wood or plastic tip instrument along with silicon spray may be required. If unable to properly clean, replace the wiper seal (SC-1513V).

CAST IRON LID WIPER SEAL INSTALLATION INSTRUCTIONS

Install the Wiper Seal (SC-1513V) in the groove of the cast iron lid with the 'U'-shape pointing upward, with the small bulge facing outward and pointing upward. Check the circumference of the installed seal for any twists or incorrect alignment of the seal in the cast iron lid groove. See Below.

INSERT THE CAST IRON LID INTO THE SS SLEEVE IN THIS DIRECTION

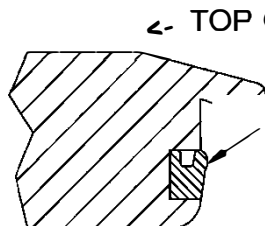

RIGHT

Install the Wiper Seal (SC-1513V) in the groove of the cast iron lid with the 'U'-shape pointing upwards and the small bulge facing outward

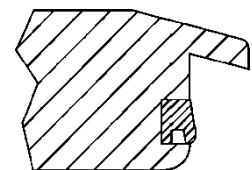

WRONG

60219016 09/16

CHECK THE STAINLESS STEEL SLEEVE FOR CLEANLINESS

- Clean the area of the stainless steel sleeve where the wiper seal makes contact with the sleeve. Using a clean rag and silicon spray, wipe this area free of any dirt, dust and/or film build up.

REINSERT THE CAST IRON LID WITH WIPER SEAL OVER THE SPILL CONTAINER AND INTO THE STAINLESS STEEL SLEEVE.

Note: To ease installation use silicon spray on the exposed surface of the wiper seal and on the lip of the stainless steel sleeve where the wiper seal makes contact. Do not use any petroleum products.

- PUSH DOWN ON THE CAST IRON LID UNTIL IT SEATS INTO THE STAINLESS STEEL SLEEVE.
- HOLD THE CAST IRON LID DOWN FOR A FEW SECONDS TO ALLOW FOR THE DISPLACED AIR TO ESCAPE.

Figure C-1
Phil-Tite SWF-100- series Rotatable Product Adaptor and
Phil-Tite SWV-101- series Rotatable Vapor Adaptor

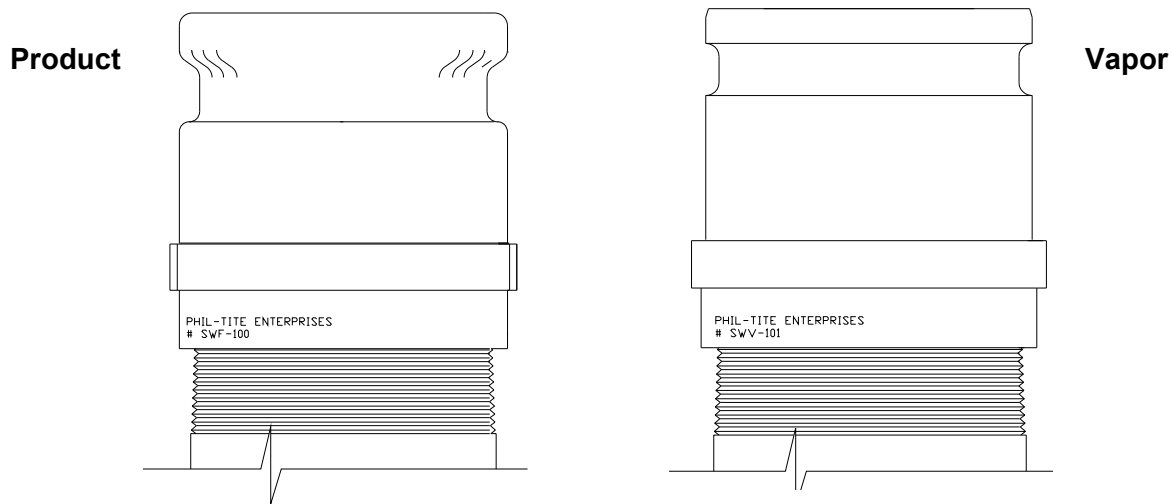

Franklin Fueling Systems - Phil-Tite
SWF-100-B/SWF-100-SS (Fill) & SWV-101-B/SWV-101-SS (Vapor) Swivel Adaptors
Installation Instructions

Swivel Adaptors are designed to be rotatable by hand from the factory and easy to install or remove. They are vapor tight and liquid tight.

INSTALLATION:

1. Remove the swivel adaptor from the box, remove foam inserts and inspect for shipping damage. Ensure that the flat seal is in place and free from damage or defects. Ensure that the vapor poppet opens and closes freely by actuating the poppet by hand. The poppet valve is designed so you can not cock it under the vapor top.
2. **IMPORTANT: Do Not Use Any Type of Thread Sealant (Pipe Dope) For Installation.**
 Phil-Tite adaptors are designed to create an optimum, vapor and liquid leak free seal when properly tightened. ***Apply an even coating of silicone based spray or a light coating of anti-seize compound to the male threads of the spill container riser and/or the swivel adaptor female threads. This will reduce the friction between these threads during installation and aid in removal of the swivel adaptor at a later date.***
3. By hand, thread the swivel adaptor onto the spill container riser, taking care not to cross thread. Turn the swivel adaptor until the ¼" flat seal makes contact with the spill container riser.
4. Using a ½ inch drive torque wrench and the special tool adaptor (T-7102, orange) from Phil-Tite Tool Kit (T-7043), tighten the adaptor to a torque value between **50 and 75 ft. lbs.**
5. Once properly tightened, install a compatible EVR dust cap listed in EO VR-101.
6. Final Check - Check the operation of the swivel adaptors.
 Phil-Tite's Fill and Vapor swivel adaptors are ARB Phase I EVR certified, as well as tested at the factory and set for a static torque of 40 inch-pounds. Using your hand, turn the top portion of the swivel adaptor; it will rotate 360 degrees by hand. The amount of torque required to turn the swivel by hand is less than the maximum allowed static torque of 108 inch pounds.

Phil-Tite's Fill and Vapor swivel adaptors are warranted against defective materials and workmanship for 1 (one) year of installation or 18 months from date of shipment, with the exception of the poppet 'O' Rings and physical damage or abuse to the adaptors. Failure to follow the above instructions can void this warranty.

Figure C-2
Franklin Fueling Systems - Phil-Tite
SWF-100- series & SWV-101- series Swivel Adaptors
Maintenance Instructions

The swivel tops should rotate 360 degrees by hand. If you can rotate the swivel tops by hand you are applying less than the maximum torque allowed of 108 in. lbs. of static torque.

The Phil-Tite rotatable adaptors are not field serviceable, with the exception of the vapor swivel poppet 'O'-Ring found on the Vapor swivel adaptor (SWV-101-B and SWV-101-SS).

If a leak is found in the vapor top poppet, inspect the brass vapor top for out of round condition. Check the poppet 'O'-Ring seal for sand, dirt, dust, grit and abrasions between the poppet 'O'-Ring and the brass sealing surface. These conditions are not covered by the warranty.

To check and/or replace the vapor swivel poppet 'O'-Ring:

1. Remove the vapor swivel adaptor (SWV-101-B or SWV-101-SS) from the black spill container riser using the special tool adaptor (T-7102, orange) from the Phil-Tite Tool Kit (T-7043).
2. Using a small blade common screwdriver remove the ¼ inch flat seal gasket from the bottom of the vapor adaptor.
3. Push down on the brass spider a ½ inch or so, using a small blade common screwdriver, remove the retainer ring. (Warning: The spider and spring assembly are spring loaded.) This will release the spider assembly, spring, and poppet assembly. By hand, carefully remove these parts.
4. With the vapor poppet assembly removed, inspect the poppet and poppet 'O'-Ring for cuts, tears or damage. Replace the 'O'-Ring if necessary. Before re-assembly, spray a small amount of Silicone Spray on the poppet 'O'- Ring. **NOTE: DO NOT USE ANY TYPE OF OIL OR GREASE.**
5. Re-assemble the vapor poppet, spring and brass spider in the reverse order from which they were removed.
6. Install the retainer ring and actuate the poppet by hand, making sure the assembly is secure and actuates properly.
7. Using a very small screwdriver, Install a new ¼ inch flat seal. Make sure the ¼ inch flat seal is seated against the sealing surface below the swivel adaptor threads.
8. Reinstall the SWV-101-B or SWV-101-SS vapor swivel on the black spill container riser as described in the "Installation Instructions" and properly torque the swivel adaptor on the spill containment container riser between **50 and 75 ft. lbs.**

Important: Apply an even coating of silicone based spray or a light coating of anti-seize compound to the male threads of the spill container riser and/or the swivel adaptor female threads. This will reduce the friction between these threads during installation and aid in removal of the swivel adaptor at a later date.

Figure D-1
Franklin Fueling Systems - Phil-Tite
M/F 4x4 Riser Adaptor Installation Instructions

M/F 4X4 RISER ADAPTOR FOR TANK RISERS
Provides A Square Cut, Flat Sealing Surface For
ALL Gasket Threaded Components To Seal Against.
Creates a Vapor and Liquid Tight Seal. Manufactured
from 5.50 X .750 X 2.75" Round Carbon Steel Tubing,
Grade 1026, Hot Finished Seamless per ASTM
A-519.

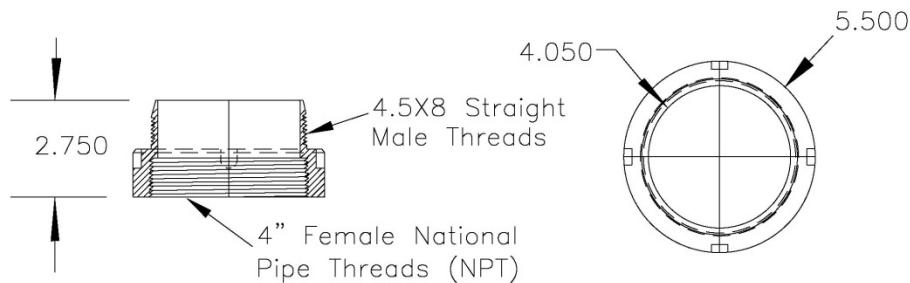

Patent No. 6,840,549 B1

Introduction

M/F 4X4 Riser Adaptors are CNC machined from Grade 1026, Round Carbon Steel Tubing, 5 ½ X ¾ inch. The female threads are NPT and a cavity is machined above these threads to provide additional room for those tank risers whose threads are tapered more than ASTM standards or the end is not cut square. The male threads are straight machine threads with the top providing a machined surface on which a gasket can seal and ensures that the seal is not compromised by improperly cut or improperly finished tank risers. This riser adaptor is to be installed on product and vapor spill containers and tank gauging risers. As an option, this riser adaptor can be installed on other connections.

1. When installing Spill Containers - When you will be installing a spill container onto the M/F 4X4 riser adaptor it is important to cut and thread the tank riser to the correct height. See the figures below or the spill container installation instructions for tank riser measurements.
2. Dry fit all components to ensure correct measurements and height adjustments before final assembly. See the two following diagrams or the spill container instructions.
3. All Other Tank Risers - For tank riser, other than spill container risers determine your required riser height, and then subtract 1 ¾ inches from your tank riser to allow for the M/F 4X4 riser adaptor.
4. Pre-Assemble – Dry fit ALL components to ensure correct measurements and height adjustments before final assembly.
5. All Tank Risers - After you have dry fit all components and are satisfied with your measurements, apply an approved fuel resistant, non hardening thread sealant (pipe dope) to the NPT threads on the male threads of the tank riser.

By hand, thread the M/F 4X4 riser adaptors onto the steel tank riser pipes. Using the approved installation tool adaptor (T-7102, Orange) and Tee handle from the Phil-Tite T-7043 Tool Kit with the appropriate ½ inch drive torque wrench; tighten the M/F 4X4 riser adaptors female NPT threads to a torque value of 175 to 200 foot-pounds.

July 2005

Figure D-2
Diagram of M/F 4x4 for use with 85000-1 Series Spill Container

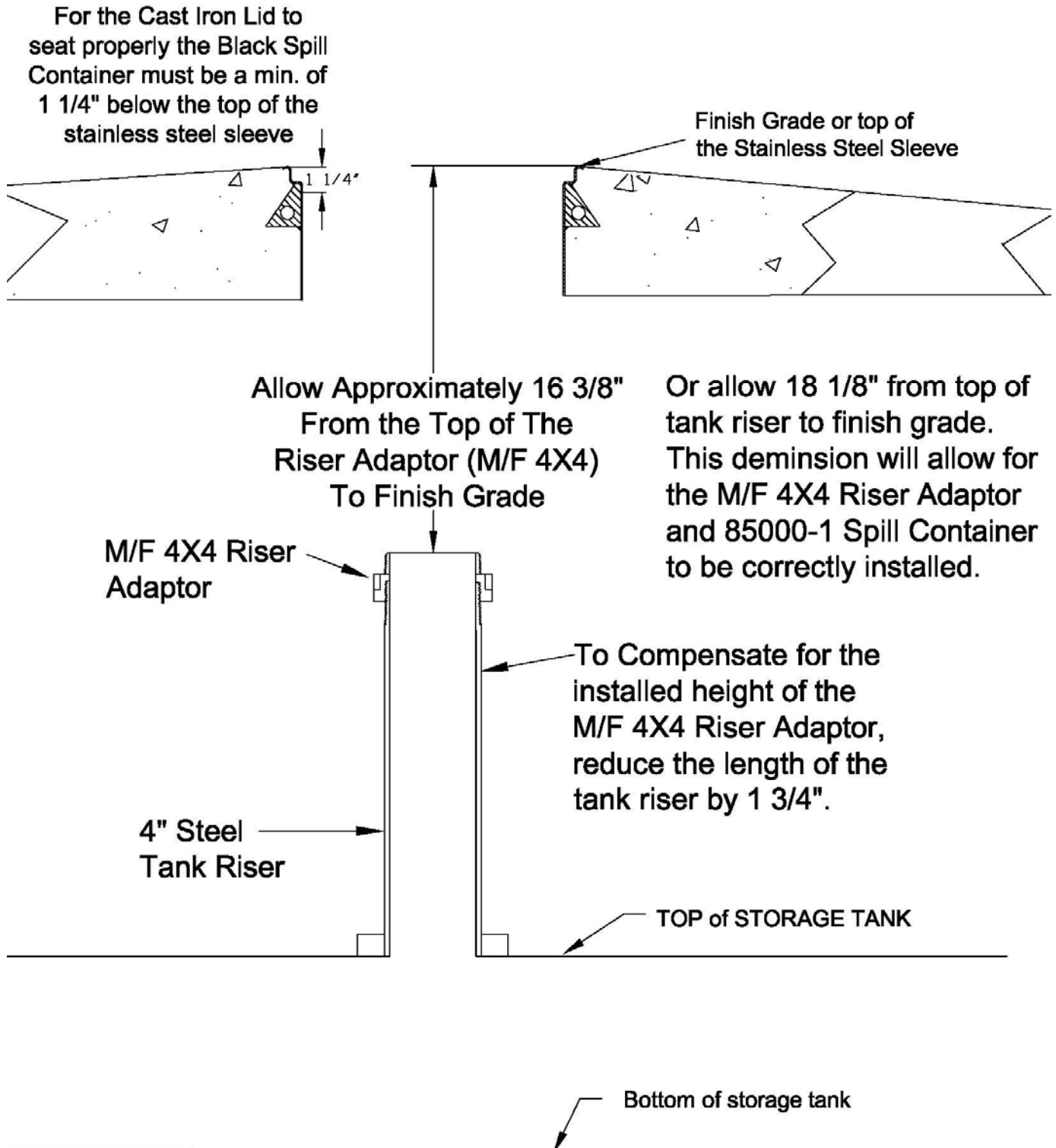

Figure E-1
Morrison Brothers Adaptor Dust Caps
323C-0100ACEVR (vapor adaptor dust cap)

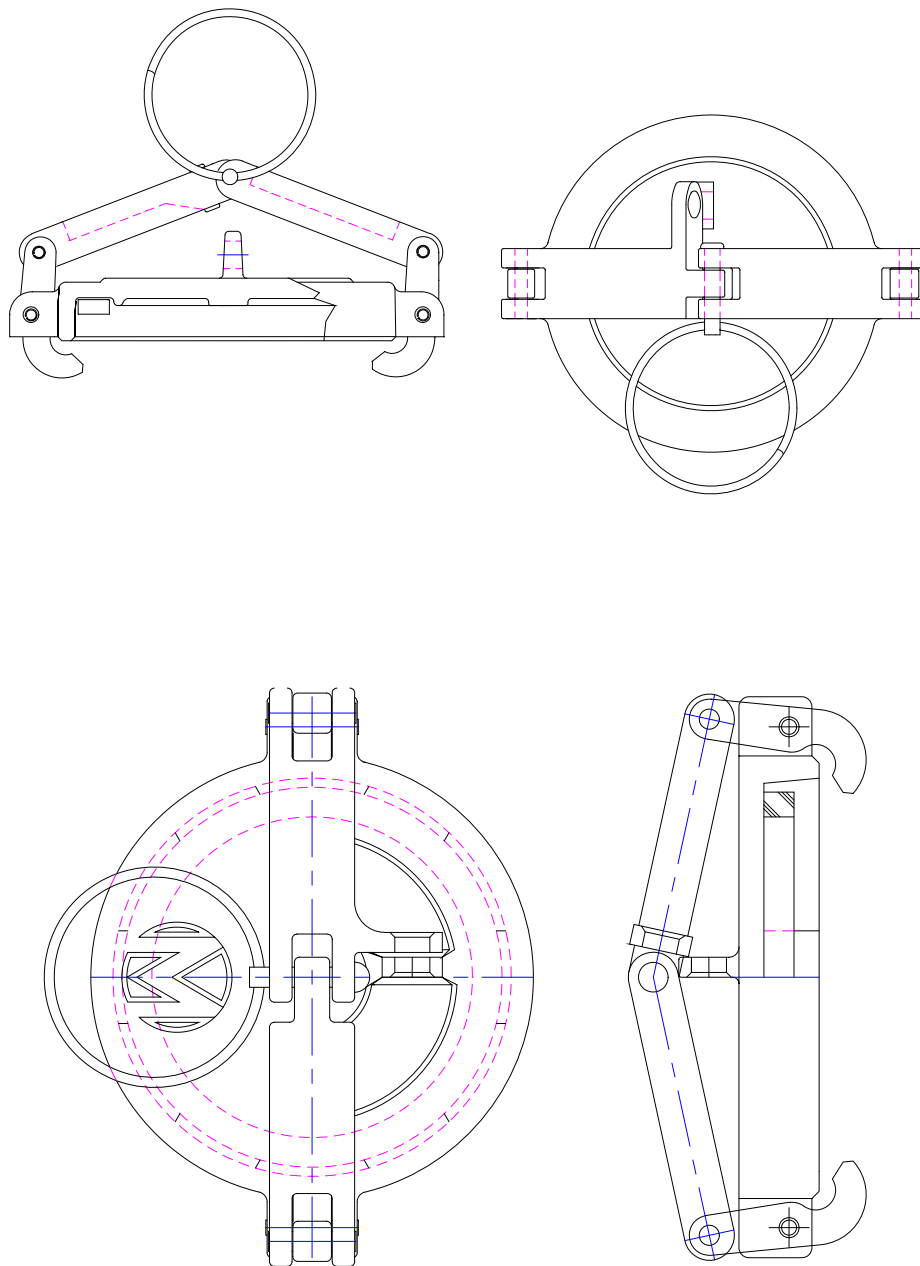
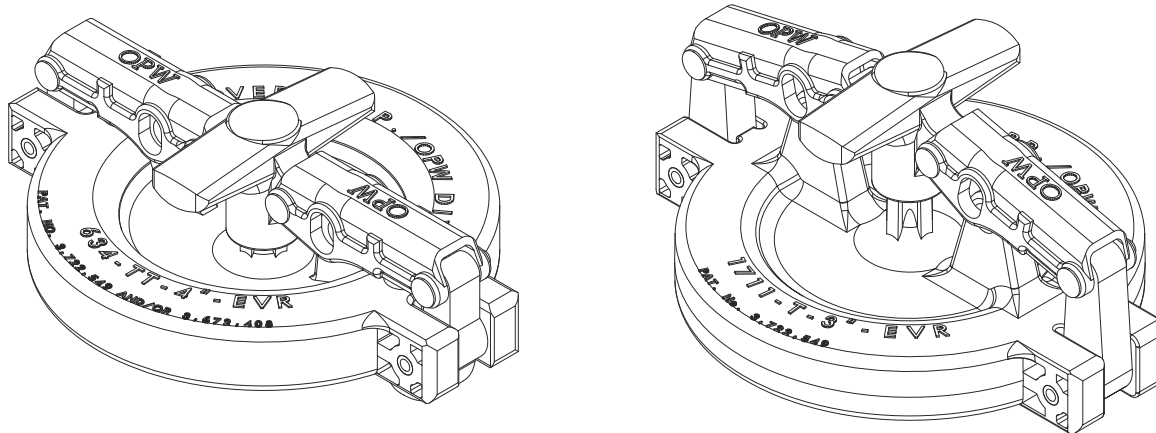

Figure E-2
OPW 634TT-EVR and 1711T-EVR Dust Caps



Operation and Maintenance:

Annually inspect seal for nicks, tears or deformations. If required replace with OPW P/N: H15005M for 634TT and H10886M for 1711T.



P.O. Box 405003 * Cincinnati, Ohio 45240-5003
1-800-422-2525 Domestically
513-870-3315 Internationally
www.opw-fc.com

Figure E-3

EBW 304 (vapor) and EBW 777 (product) Dust Caps

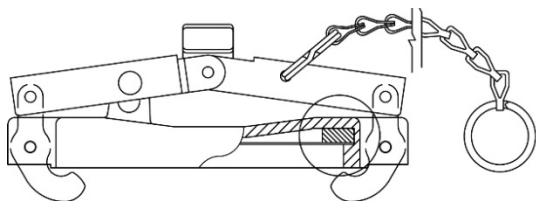

**EBW 304-301-03 Vapor (Gas/E85)
EBW 304-200-06 Vapor (Gas/E85)**

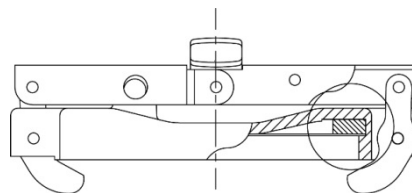

**EBW 777-201-02 Product (Gas/E85)
EBW 777-202-02 Product (Gas/E85)**

Visually inspect the seal in cap and replace if damaged or missing.

Use replacement parts:

Vapor and Product Caps (Gas/E85): (950-215-01)

Figure E-4
OPW 634LPC (product) and 1711LPC (vapor) Dust Caps

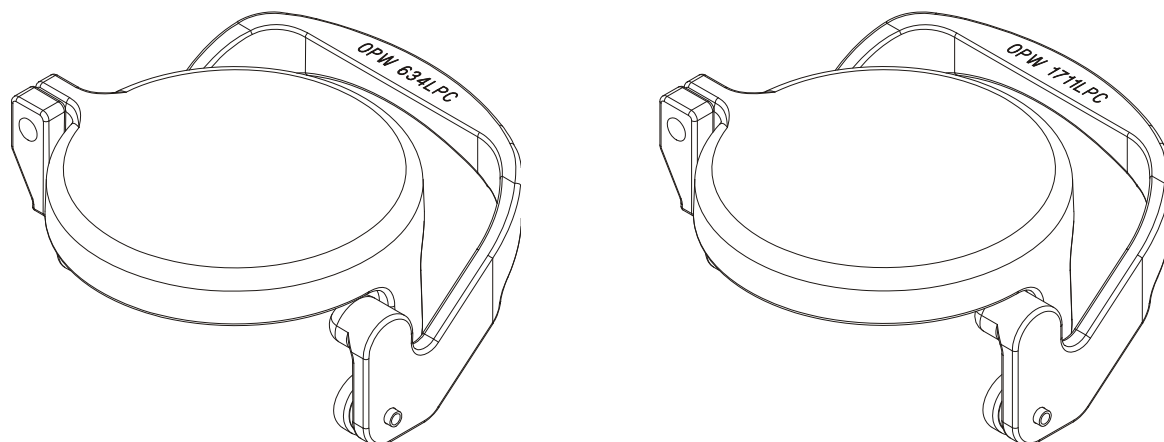

Operation and Maintenance:

Annually inspect seal for nicks, tears or deformations. If required replace with OPW P/N: H15005M.



P.O. Box 405003 * Cincinnati, Ohio 45240-5003

1-800-422-2525 Domestically

513-870-3315 Internationally

www.opw-fc.com

Figure E-5
CompX Security Products (CSP)
CSP1-634LPC (product), CSP2-634LPC (product),
CSP3-1711LPC (vapor) and CSP4-1711LPC (vapor)
Tank Commander Dust Caps

TANK Commander – Warranty

Seller warrants to the initial and subsequent purchasers, for a period of one year from date of installation, that the Products sold hereunder will, at the time of delivery: (a) comply with the ARB CP-201 standards and specifications for the duration of the warranty period for such Products in effect at the time of shipment or such other specifications as are expressly agreed upon by Seller and Buyer in writing; (b) be adequately contained, packaged, and labeled; and (c) conform to any promises and affirmations of fact made on the container and label. In the event that any such Products fail to conform to the foregoing warranty, Seller will, at its option, repair or replace such nonconforming Products, or credit Buyer for an amount not to exceed the original sales price of such Products. Shipping costs incurred in returning such nonconforming Products to Seller shall be borne by Seller, but Seller shall in no event be liable for any inspection, handling, or packaging costs incurred by Buyer in connection with such Products. Buyer's negligence, misuse, improper installation, or unauthorized repair or alteration, shall void this warranty.

The TANK Commander Warranty tag is located on the inside cover of the product.

Tank Commander features:

Tank Commander fits all certified Phase 1 Vapor Recovery Systems: Phil-Tite, OPW, EBW, CNI and EMCO Wheaton

- ♦ Stainless steel construction
- ♦ Vapor recovery seal remains intact
- ♦ Low profile fill cap included
- ♦ Fits common bronze adapters
- ♦ 24/7 protection for diesel and gas

TuBAR Tank Commander

- ♦ TuBAR® lock for maximum key control
 - No key blanks available except from factory
 - Key series registered to your store(s)
- ♦ Keyed alike available – use the same key for both Tank Commander and dispenser

Padlock Tank Commander

- ♦ Available with heavy duty four number changeable combination padlock
- ♦ Or use existing padlock

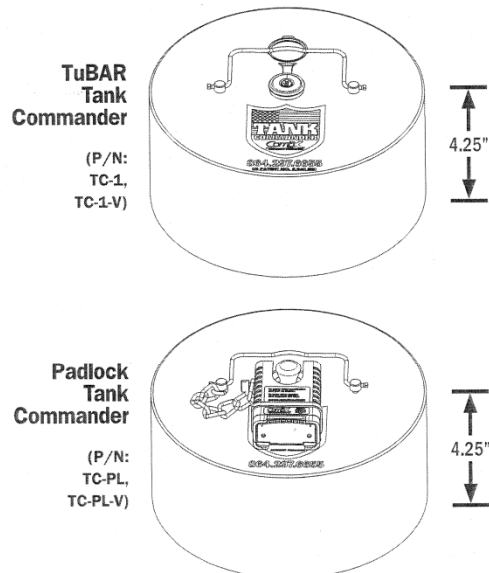

ISO 9001 certified.

Copyright 2012 © CompX Security Products / 864.297.6655 / compx.com / PO Box 200, Mauldin, SC 29662
 Any companies and/or products referred to herein are either registered trademarks of their respective companies, owners and/or mark holders.

TANK Commander – Instructions

Product Instructions

Remove existing dust cap OPW 634LPC, OPW 634IT-EVR, Morrison Brothers 305C 0100ACEVR, EBW 777-201-01, EBW 777-201-02, CNI Mfg. 64, OR EMC Wheaton Retail A0097-005 and replace with appropriate TANK Commander dust cap, CSP1-634LPC, CSP2- 634LPC, CSP3- 1711LPC or CSP4-1711LPC. Make sure the handle lever is fully locked and the dust cap seal is engaged.

Annually inspect dust cap seal for nicks, tears or deformations and replace if necessary. Installation of TANK Commander should not violate any (height) limitations exhibited in California Air Resources Board Executive Orders VR101-VR105. If the original Vapor Recovery System installation will not allow correct installation of TANK Commander then modification to the vapor recovery system is required (i.e. fill pipe height reduction) to maintain installation requirements.

TuBAR TANK Commander (P/N: TC-1, TC-1-V)

Insert key into the keyway of the lock on top of the stainless steel TANK Commander and rotate clockwise to retract locking bolt. Install stainless steel TANK Commander over the CSP1-634LPC product dust cap or CSP3-1711LPC vapor dust cap ensuring the lock body mounted in the sleeve fully engages the brass boss on top of the dust cap. Return the key to the 12 o'clock position and remove. The TANK Commander is now secured to the dust cap and should rotate freely.

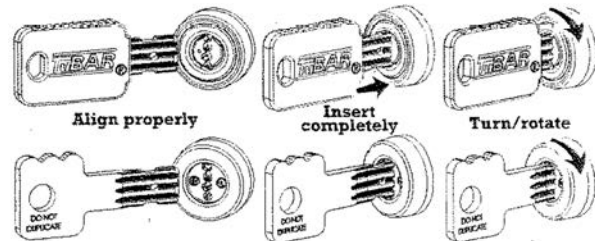

Padlock TANK Commander (P/N: TC-PL, TC-PL-V)

Install stainless steel TANK Commander over dust cap spindle on CSP2-634LPC or CSP4-1711LPC; install padlock shackle through the spindle hole. Secure TANK Commander by locking the padlock; product should rotate freely.

To Change the Combination: Open the lock using the proper combination and pull the shackle up to unlock. Turn the shackle 90° then press down completely. Now rotate another 90° to the left.

The factory combination is 0-0-0-0. Be sure to record new combination. Warranty does not cover lost, stolen or incorrectly set combinations.

To Open: Spin the dials so the proper numbers align on top with the black hash marks. Pull the shackle up to unlock.

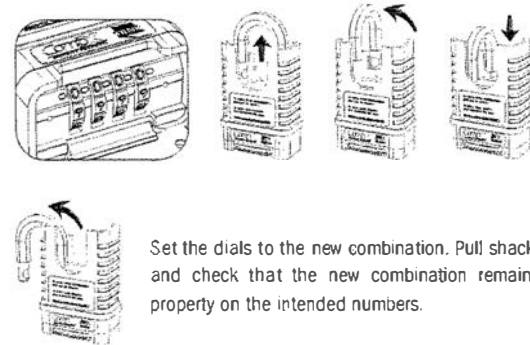
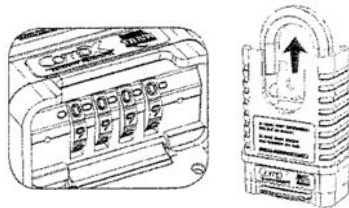

Set the dials to the new combination. Pull shackle up and check that the new combination remains set properly on the intended numbers.

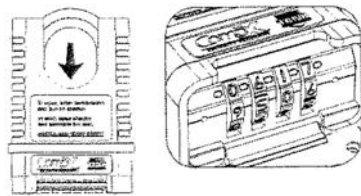

To Close: Push the shackle down to close. Scramble dials to lock the shackle. The dials will only spin when the shackle is in the locked position.

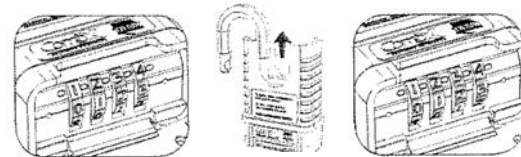

See previous instructions (on left) to close and lock



copyright 2012 © CompX Security Products / #64.297.6655 / c

Standard Product Warranty on back.

ISO 9001 certified.

Figure F-1
Franklin Fueling Systems (FFS) PV-Zero Pressure/Vacuum Vent Valve





PV-ZEROTM
Liquid-Filled Pressure/Vacuum Vent Valve
FFS P/N 407215901

**Installation, Testing
and Maintenance Manual**

Warning  This symbol identifies a warning. A warning sign will appear in the text of this document when a potentially hazardous situation may arise if the instructions that follow are not adhered to closely. A potentially hazardous situation may involve the possibility of severe bodily harm or even death.

Caution  This is a caution symbol. A caution sign will appear in the text of this document when a potentially hazardous environmental situation may arise if the instructions that follow are not adhered to closely. A potentially hazardous environmental situation may involve the leakage of fuel from equipment that could severely harm the environment.

Danger  This symbol identifies an electrical danger. An electrical danger sign will appear in the text of this document when a potentially hazardous situation involving large amounts of electricity may arise if the instructions that follow are not adhered to closely. A potentially hazardous situation may involve the possibility of electrocution, severe bodily harm, or even death.

Warning  **Follow all federal, state and local laws governing the installation of this product and its associated systems. When no other regulations apply, follow NFPA codes 30, 30A and 70 from the National Fire Protection Association. Failure to follow these codes could result in severe injury, death, serious property damage and/or environmental contamination.**

Warning  **Always secure the work area from moving vehicles. To help eliminate unsafe conditions, secure the area by using a service truck to block access to the work environment, or by using any other reasonable means available to ensure the safety of service personnel.**

Warning  **The PV-ZERO is used with tanks containing gasoline or other flammable substances, you may create an explosion hazard if you do not follow the requirements in this manual carefully.**

Description of the FFS PV-ZERO Liquid Filled P/V Vent Valve

The PV ZERO operates using a similar concept to a common P Trap used in plumbing drain applications to create a liquid air seal. The liquid seals the UST ullage vapors from the atmosphere while still maintaining the proper differential pressure set points. After the differential pressure has been exceeded, air or vapor bubbles through the liquid media until the pressure returns to the operational pressure settings. Figures 1-3 illustrate the operation of the PV ZERO.

The PV ZERO has no moving parts and the only maintenance required is periodic inspection of the liquid.

Because the PV ZERO does not use seals or gaskets to seal off the UST ullage from atmosphere, the unit will not allow vapor or air to pass through at pressure less than the cracking set point. As long as the valve is filled with 1.6 liters (54 ozs) of PV ZERO fluid, the stainless steel valve housing is not damaged, and the pipe fittings are correctly installed, the unit should be leak free.

The liquid used for the PV ZERO unit is silicone based and has a very low vapor pressure and low toxicity.

The PV ZERO can be mounted either at the top of the vent rack or in-line (mid-mount at working level). To avoid the risk of climbing a ladder and to maximize the simplicity of inspection and service, the preferred installation of the PV ZERO is to be mounted in-line. It can be mounted on a single riser pipe or many riser pipes manifolded to a single line. The PV ZERO is designed to mount on 3" riser piping, but can also be installed on 2" riser piping.

See drawings on pages 9-11 for mounting options.

*** Refer to CARB EVR documents regarding equipment rules for manifold systems.***

A support frame should be used for mounting all vent riser piping and must be used to stabilize the piping above the PV ZERO if it is to be mounted in-line.

If the PV ZERO is to be top mounted, the support frame must stabilize the piping below the unit (and the unit itself). Check local agencies for support frame requirements and consult a licensed structural engineer in doubt of the structural integrity of the vent rack support system.

Note: Do not mount the PV ZERO unit on a free standing vent piping system without a support frame!

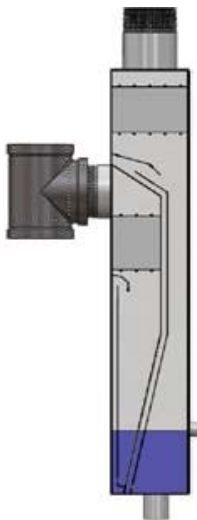

Figure 1: No Differential

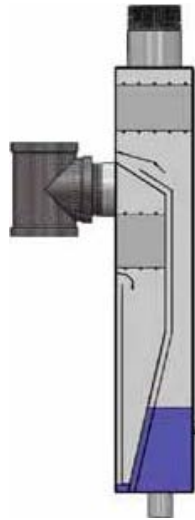

Figure 2: Positive Cracking

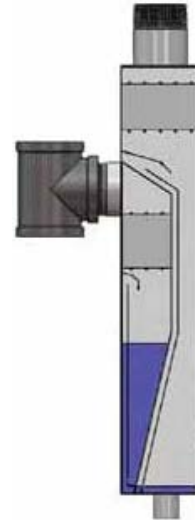

Figure 3: Negative Cracking

Installation

Note: Use a thread sealant that is approved for gasoline and gasoline-ethanol blends such as Gasoil Soft Set or Jomar Heavy Weight for all threaded pipe fittings and plugs. The 3" side tee and 1" bottom drain plug are factory installed. Tighten all fittings per recognized industry installation standards.

1. Thread the bottom of the 3" side tee onto the vent riser piping. The PVZERO may be mounted mid-line or top mounted on a single riser or a manifolded system (see drawings, pages 9 & 10). For 2" riser piping systems, use a 3x2" NPT reducing coupling with a 3" pipe nipple at least 6" long (see drawing, page 11)
2. Make sure the PVZERO unit is plumb within $\pm 3^\circ$ and not set at an angle. Failure to set in the vertical position may cause improper operation.
3. For mid-line mounting installations, install and secure the rest of the 3" discharge piping on the vent rack (refer to NFPA 30 for specific fuel system vent piping requirements). **Be sure to use a pipe wrench to counteract the tightening force to the valve!**
4. Fill the PV-ZERO unit through the side port with 1.6 liters (54 oz.) of PVZERO fluid (FFS p/n 407220001) provided with the unit. It may also be filled through the discharge outlet fitting (top). **Do not pour into the 3" side tee fitting!**

Note: To fill the fluid in the PVZERO, the UST (Underground Storage Tank) must be open to the atmosphere OR the inflatable test plug needs to be installed to reach the correct level. If the tank is under pressure or vacuum, the correct fill level cannot be obtained.

5. Install the side plug.
6. Perform the **Field Testing Procedure**.
7. Install the 3" pipe plug on top of the tee.
8. Attach the 3" upward-venting rain cap provided. Attach to the top of the vent pipe (mid-mount installation) or directly to the top of the PVZERO (top mount) **Keep the rain cap installed to minimize water intrusion, and to ensure proper operation.**

The PVZERO may be painted, however, do not paint over or cover the nameplate placards decals.

Field Testing

Note: Compliance testing of the PVZERO, if required by the local air quality district, shall be conducted in accordance with California Air Resources Board (CARB) test procedure TP-201.1E and Exhibit 2 of the Executive Order. This test shall be conducted using the PV ZERO test cap assembly (FFS p/n 407225901) with the valve in its installed condition. The PV ZERO can be tested without removing the unit from the vent rack.

There are (3) ports on the PVZERO test cap assembly (see page 8):

- 1 – Schrader valve connection for the inflatable plug
- 1 – 1/4" hose barb (for pressure/vacuum supply)
- 1 – 1/8" hose barb (for manometer)

Remove 3" pipe plug from top of tee (if necessary)

2. Install the test cap assembly through the top of the 3" tee, allowing the inflatable plug to extend into the vent riser pipe - tighten fully.
3. Inflate the inflatable plug to 35 PSI.
4. Test per CARB TP-201 1E
5. Deflate the inflatable plug.
6. Remove test cap assembly from 3" tee.

Recommended Maintenance Intervals

- o**Every year:** Visually inspect the housing, pipe, fittings, and rain cap for obvious signs of damage, missing parts, or fluid leaks.
- o**Every year:** Visually inspect the rain cap, from ground level, for signs of bird nests or insect activity.
- o**Every year:** Drain and inspect the fill fluid per the **Fluid Inspection Procedure.**

Fluid Handling

The PV-ZERO is filled with a silicone based fluid, p/n 407220001 (contact FFS for MSDS sheet). The PV-ZERO fill fluid is resistant to UV exposure, does not support bioactivity and is resistant to oxidation.

Since the PV-ZERO is exposed to tank ullage vapors, used PV-ZERO fill fluid may contain trace amounts of ethanol and gasoline. The maintenance technician servicing the PV-ZERO should wear appropriate eye protection and nitrile gloves when inspecting or servicing the fill fluid. Check with local and state regulations regarding handling, transportation, recycling and disposal of silicone based fluids.

Fluid Inspection Procedure

1. Remove the 3" NPT plug from the top of the side tee.
2. Remove the 3/8" NPT side plug.
3. Remove the 1" NPT bottom plug and drain the fluid into a clean, transparent container.
4. Visually inspect the fill fluid for debris or water contamination. Since the specific gravity of the fluid is slightly less than water, any water in the fluid will settle to the bottom. The fluid can be reused indefinitely as long as it is free of sediment and water.

Note: Clean fluid can be refilled into the valve and topped off with new fluid, or it can be completely replaced with new fluid.

5. Reinstall the 1" NPT bottom plug.
6. Refill the PV-ZERO valve with fluid through the side-port until it spills out of the port. This is the correct fill level of 1.6 liters (54 oz.).
7. Reinstall the 3/8" NPT side plug.
8. Perform the **Field Testing Procedure**
9. Reinstall the 3" NPT plug in the top of the side tee.

Only use the approved PV-ZERO fluid (P/N 407220001). Substitution of other fluids voids the warranty and can cause vapor leaks!

PV-ZERO Specifications

Height:	33.5"
Width:	5.0"
Length:	12.3"
Dry weight:	20#
Inlet piping connection	3" NPT
Discharge piping connection	3" NPT
Fill port	3/8" NPT
Drain port	1" NPT
Construction material	304 stainless steel
Fuel Compatibility	Gas & E85
Pressure leak rate	<< 0.05CFH at +2.0 W.C.
Vacuum leak rate	<< 0.21 CFH at -4.0 W.C.
Pressure drop at 60 cfm flow rate with tank positive pressure	14" W.C.
Pressure drop at 90 cfm flow rate with tank positive pressure	28" W.C.
Minimum operating temperature	-40° F (-40° C)
Maximum operating temperature	130° F (54° C)
Maximum test pressure	5 PSI
Maximum mounting angle deviation from vertical	3°

Drawing List:

Page	Drawing Description
6	PV-ZERO Operating Assembly
7	PV-ZERO Overall Dimensions
8	Test Cap Description
9	3" Manifoldded Mid Mount
10	3" Mounting Assembly
11	2" Mounting Assembly

The drawings are on the following pages

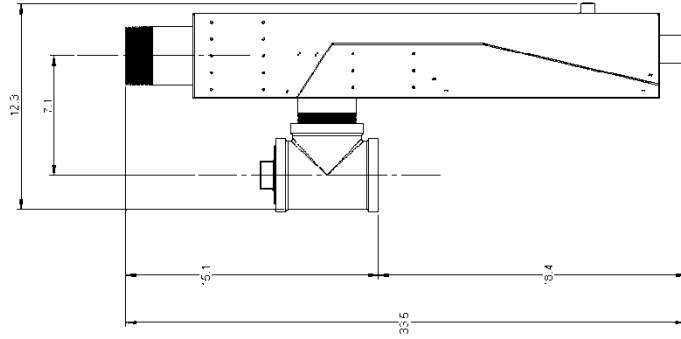
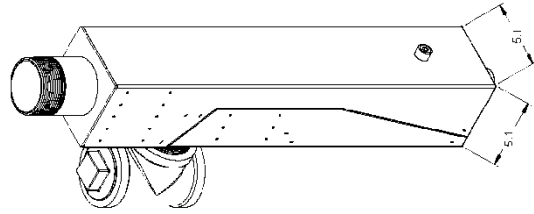

This information is the property of Franklin Fueling Systems, Inc. Neither this drawing nor the information disclosed hereon may be reproduced, stored in a retrieval system, or transmitted in any form or by any means, electronic, mechanical, photocopying, recording, or by any information storage and retrieval system, without the prior written permission of Franklin Fueling Systems, Inc. This drawing must be returned to Franklin Fueling Systems, Inc. upon request.

MATERIAL:
SEE BOM

DO NOT SCALE DRAWING: XX, ± .02
STANDARD INCH TOLERANCES: XXX, ± .005
(UNLESS OTHERWISE SPECIFIED) ANGULAR: ± .12°
SPEC'IA_D ST

Franklin Fueling Systems
4600 W. WI 23718

TITLE: PV-ZERO OVERALL DIMENSIONS

DESIGNER KV	DATE 11/14/08	DRAWN DERWIC	SUFFIX
APPROVAL DATE	SCALE 1:1	SHEET 1	OF 1

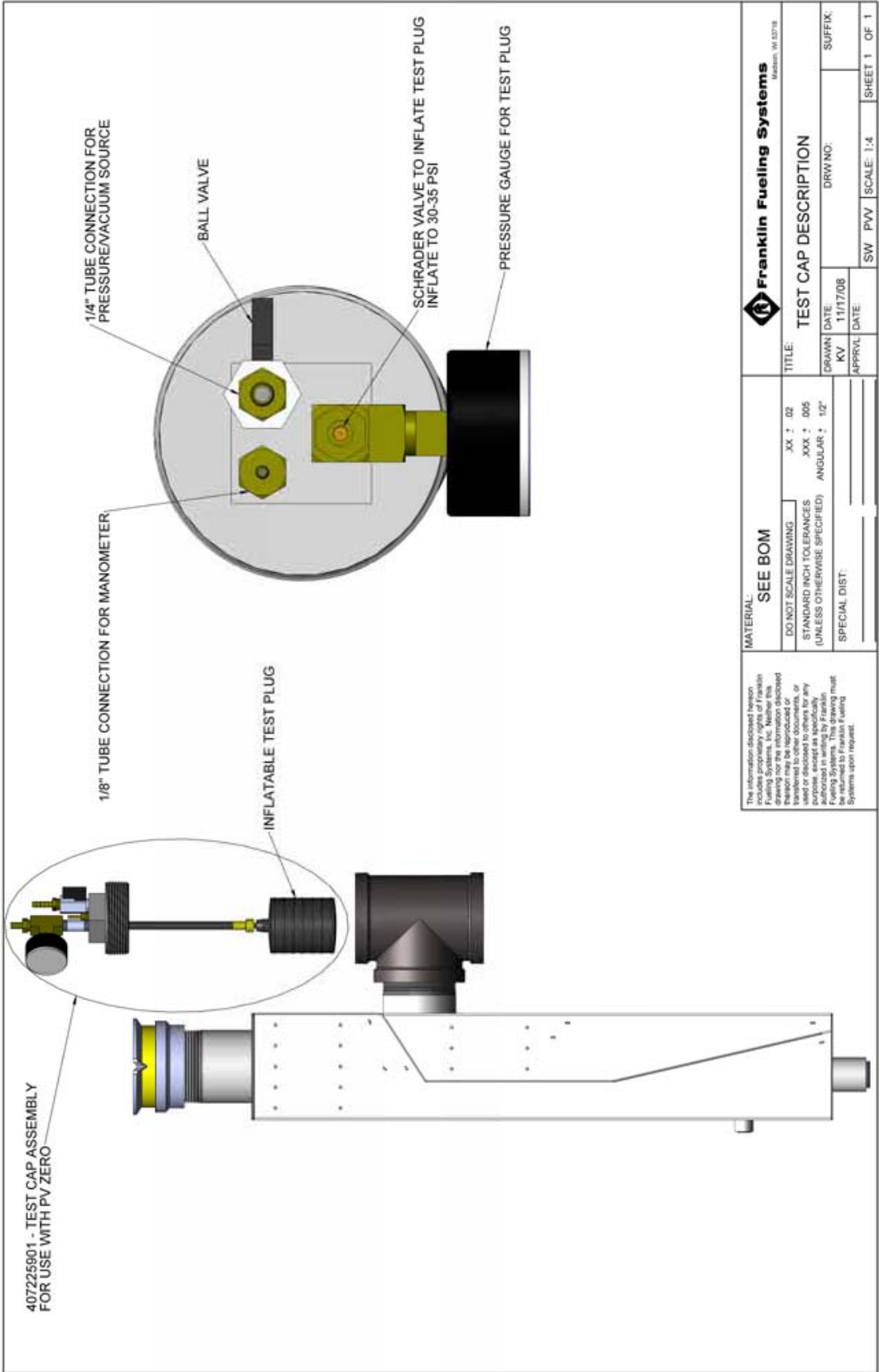

<p>Franklin Fueling Systems <small>Franklin Fueling Systems, Inc. 10000 W. 137th St. Overland Park, MO 66204</small></p>	
<p>MATERIAL: SEE BOM</p>	
<p><small>The information disclosed herein is the property of Franklin Fueling Systems, Inc. Neither this drawing nor the information disclosed hereon is to be reproduced, stored in a retrieval system, or transmitted in any form or by any means, electronic, mechanical, photocopying, recording, or by any information storage and retrieval system, without the prior written permission of Franklin Fueling Systems, Inc. This drawing must be returned to Franklin Fueling Systems upon request.</small></p>	
<p>TITLE: TEST CAP DESCRIPTION</p>	
<p>DO NOT SCALE DRAWING</p>	<p>XX : 02</p>
<p>STANDARD INCH TOLERANCES (UNLESS OTHERWISE SPECIFIED)</p>	<p>XXX : + .005</p>
<p>SPECIAL DIST:</p>	<p>ANGULAR : 1/2°</p>
<p>DRAWN DATE: 11/17/08</p>	<p>DRW/NO:</p>
<p>APPRVL DATE:</p>	<p>SUFFIX:</p>
<p>SW PV SCALE: 1:4</p>	<p>SHEET 1 OF 1</p>

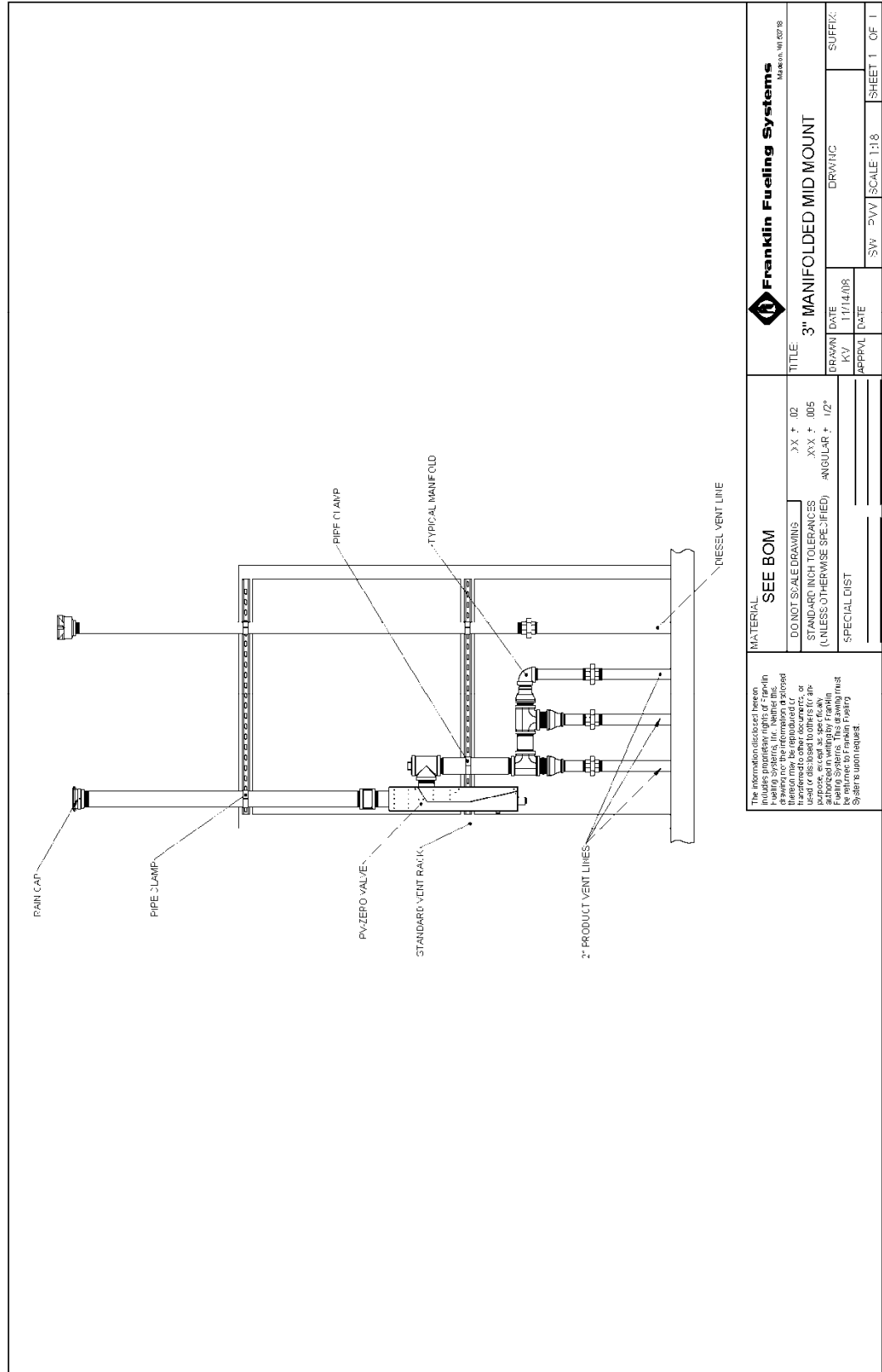

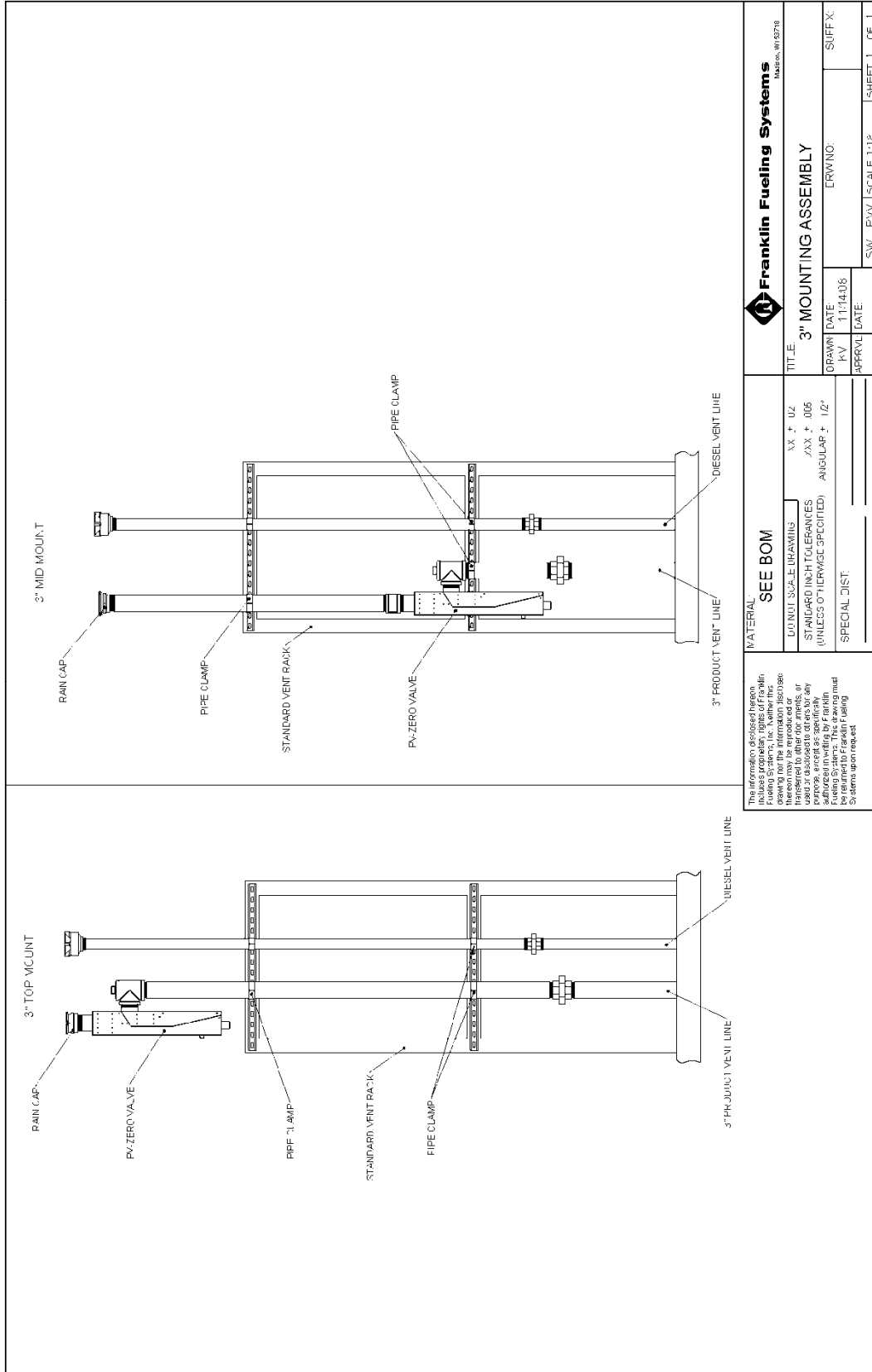

<p>Franklin Fueling Systems <small>Franklin, WI 53128</small></p>		<p>TITLE: 3" MANIFOLDED MID MOUNT</p>		<p>SCALE: 1:18</p>	<p>SHEET 1 OF 1</p>
<p>MATERIAL: SEE BOM</p>		<p>DO NOT SCALE DRAWING: .XX + .02</p>	<p>STANDARD INCH TOLERANCES (UNLESS OTHERWISE SPECIFIED): .XX + .005</p>	<p>DATE: 11/14/08</p>	<p>DRWING: DRWING</p>
<p>DO NOT SCALE DRAWING: .XX + .02</p>		<p>STANDARD INCH TOLERANCES (UNLESS OTHERWISE SPECIFIED): .XX + .005</p>		<p>DATE: 11/14/08</p>	<p>SUFFIX:</p>
<p>SPECIAL DIST:</p>		<p>APPROVAL DATE:</p>		<p>SCALE: 1:18</p>	<p>SHEET 1 OF 1</p>
<p><small>The information on this sheet is for informational purposes only. It is not intended to be used as a substitute for the information contained in the original drawing. The information is not to be used or disclosed to other parties without the written consent of Franklin Fueling Systems. This drawing must be used in conjunction with the original drawing. Special requests must be made in writing.</small></p>					

10

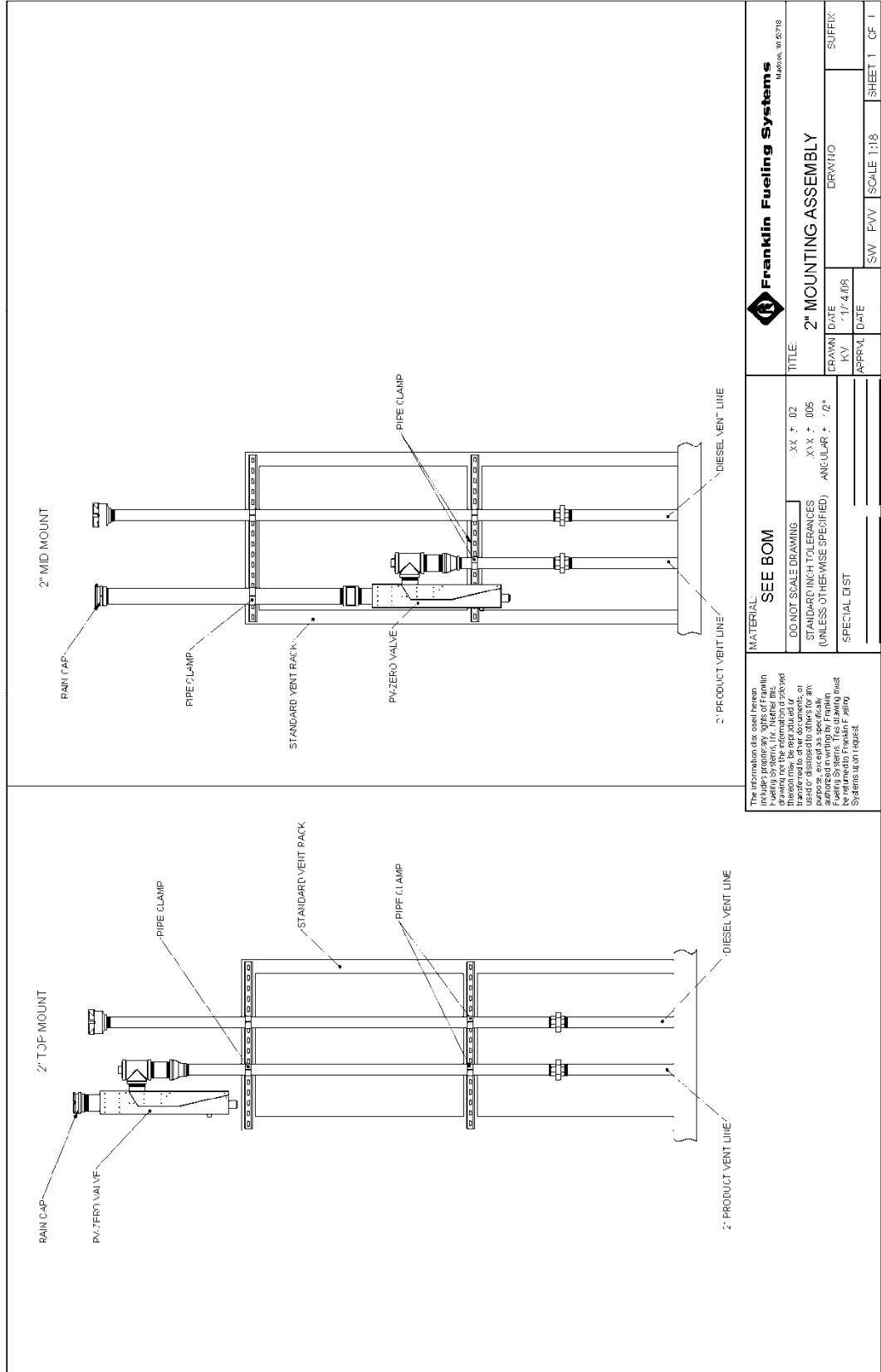

<p>The information disclosed herein includes proprietary rights of Franklin Fueling Systems, Inc. and may be used for informational purposes only. It is not to be reproduced or transmitted in any form or by any means, electronic or mechanical, including photocopying, recording, or by any information storage and retrieval system, without the prior written permission of Franklin Fueling Systems, Inc. All rights reserved. This document is the property of Franklin Fueling Systems, Inc. and must be returned to Franklin Fueling Systems upon request.</p>		<p>Franklin Fueling Systems MADISON, WI 53718</p>
<p>SEE BOM</p> <p>DO NOT SCALE DRAWINGS</p> <p>STANDARD INCH TOLERANCES (UNLESS OTHERWISE SPECIFIED)</p> <p>SPECIAL DIST.</p>		<p>TITLE: 3" MOUNTING ASSEMBLY</p> <p>DATE: 11/14/08</p> <p>SCALE: 1:18</p> <p>SHEET 1 OF 1</p>
<p>XX * UZ</p> <p>XX * 005</p> <p>ANGULAR * 1/2"</p>	<p>DATE: 11/14/08</p> <p>SCALE: 1:18</p>	<p>DATE: 11/14/08</p> <p>SCALE: 1:18</p>



 Franklin Fueling Systems <small>Madison, WI 53718</small>	
TITLE: 2" MOUNTING ASSEMBLY	
DRAWN: KV	DATE: 11/4/08
APPROVAL: _____	DATE: _____
MATERIAL: SEE BOM	.XX ± .02 .XX ± .005 (UNLESS OTHERWISE SPECIFIED) ANGULAR ± .2° SPECIAL LIST
DO NOT SCALE DRAWING	.XX ± .02
STANDARD INCH TOLERANCES	.XX ± .005
(UNLESS OTHERWISE SPECIFIED)	ANGULAR ± .2°
SPECIAL LIST	SPECIAL LIST

This drawing is the intellectual property of Franklin Fueling Systems, Inc. No part of this drawing may be reproduced, stored in a retrieval system, or transmitted in any form or by any means, electronic, mechanical, photocopying, recording, or by any information storage and retrieval system, without the prior written permission of Franklin Fueling Systems, Inc. This drawing is the property of Franklin Fueling Systems, Inc. and is loaned to you for your use only. It is not to be distributed, copied, or otherwise used without the prior written permission of Franklin Fueling Systems, Inc. If you have any questions, please contact your account manager.



Franklin Fueling Systems

www.franklinfueling.com

3760 Marsh Road • Madison, WI 53718, U.S.A.

Tel: +1 608 838 8786 • Fax: +1 608 838 6433

Tel: USA & Canada 1 800 225 9787 • Tel: México 001 800 738 7610

Franklin Fueling Systems GmbH

Rudolf-Diesel-Strasse 20 • 54516 Wittlich, GERMANY

Tel: +49-6571-105-380 • Fax: +49-6571-105-510

Figure F-2 Husky Model 5885 Pressure/Vacuum Vent Valve



IMPORTANT SAFETY INSTRUCTIONS - SAVE THESE INSTRUCTIONS IN A READILY ACCESSIBLE LOCATION.

WARNING Designed for use at motor fuel dispensing facilities only.

INSTALLATION INSTRUCTIONS

NOTE: Always adhere to installation / usage instructions and warnings. Improper use may result in injury, damage or hazardous spill.

1. Remove the Pressure Vacuum (PV) vent from the carton and visually inspect for any shipping damage. Shipping damage would include loose components in the carton or noticeable dents in the housing or rain hat. Do not touch the internal components. If concerned about shipping damage, perform the California Air Resources Board (CARB) TP-201.1E bench test before installing.
2. Remove the old PV vent and use a wire brush or similar tool to remove all debris from the vent stack threads.
3. Apply fuel resistant pipe sealant (not Teflon● tape) to the threads on the 2" / 50.8 mm vent stack. We recommend the thread sealing compound Gasoila● Soft-Set or equivalent that is UL Classified.
4. Bring the PV vent to the top of the vent stack without tossing it or touching internal components.
5. Screw the PV vent onto the vent stack by hand. Tighten firmly with a 1-1/8" (29 mm) wrench using the hex fitting on top of the vent with approximately 20-50 lbf·ft / 27.1 – 67.8 N·m torque, but do not overtighten.

CAUTION: DO NOT ALTER OR COVER THE P/V VENT

TESTING / MAINTENANCE / INSPECTION

Testing Criteria Per TP201.1E and Exhibit 3 of applicable Phase 1 E.O.

Leak rate: Pressure = .05 CFH @ 2" wc, Vacuum = .21 CFH @ -4" wc.
Cracking Pressure = 2 1/2" to 6" wc, Vacuum = -6" to -10" wc.



Annually Inspect the P/V vent valve for foreign objects:

1. Remove the screws that hold on the top cover. Do not remove the screens.
2. Remove any debris from inside the lower cover.
3. Check the drain holes in the lower cover.
4. Reinstall the top cover.
5. Tighten the screws firmly.

- All drive aways, maintenance and inspection activities must be logged using the serial number of the individual product.

- Apply city, state, or federal testing regulations as appropriate.

**ANY TEST / INSPECTION FAILURE
REQUIRES IMMEDIATE EQUIPMENT
REPLACEMENT OR REMOVAL
FROM SERVICE.**

MADE IN THE USA

▲ ALWAYS ADHERE TO INSTALLATION / USAGE INSTRUCTIONS AND WARNINGS. ▲

Improper use may result in injury, damage, or hazardous spill.

▲ GENERAL WARNINGS / INSTRUCTIONS PERTAINING TO A RISK OF FIRE, ELECTRIC SHOCK OR INJURY TO PERSONS:

- Use of equipment is at individuals' own risk
- Always abide and adhere to city, state, and federal regulations regarding use and installation of dispensing equipment

Always follow the dispenser manufacturer's instructions

 Always disconnect power to dispenser during maintenance and inspection activities

- Always close the bleed valves during maintenance and inspection activities.

Always relieve pressure from system prior to performing maintenance activities.

 Always check continuity after installation using a megohmmeter (Refer to PEI RP 400 for details).

Always replace or remove from service damaged or leaking dispensing equipment immediately.

 Always report leaks / spills / accidents to appropriate authorities.

 Always wear appropriate safety equipment during maintenance activities.

- Always have appropriate fire extinguishing equipment within 5 ft / 1.5 m of dispensers.

 Always use pipe sealant approved for gasoline service.

- Always place containers on the ground before filling
- Always discharge static electricity before using or servicing equipment by touching a metal part of the dispenser before and after fueling vehicle
- Never smoke within 20 ft / 6.1 m of dispensers.
- Never keep in service past recommended life.
- Never leave the nozzle unattended while dispensing fuel.
- Never use sparking or flaming devices within 20 ft / 6.1 m of dispensers.



- Never use power tools near dispensers or to aid in the installation process.



- Never use cell phone within 20 ft / 6.1 m of dispensers.



- Never reenter car when fueling vehicle.



- Never allow gasoline to touch eyes or skin.



- Never use at flow rates in excess of regulatory guidelines.



- Never use at flow rates less than 5 gpm / 18.9 Lpm.

- Never dispense flammable material into unapproved containers.

- Never dispense fuel without a valid driver's license.

CAUTION: DO NOT ALTER OR COVER THE P/V VENT.

DO NOT OVERTIGHTEN.

IMPORTANT SAFETY INSTRUCTIONS - SAVE THESE INSTRUCTIONS IN A READILY ACCESSIBLE LOCATION.

WARRANTY

VAPOR PRODUCTS – Husky Corporation will, at its option, repair, replace, or credit the purchase price of any Husky manufactured product which proves upon examination by Husky, to be defective in material and/or workmanship for a period of one (1) year of installation or fifteen (15) months from the manufacture date of shipment by Husky, whichever occurs first. The warranty period on repaired or replacement vapor recovery products is only for the remainder of the warranty period of the defective product.

EVR PRODUCTS – With respect to EVR products installed in California, for a period of one (1) year from the date of installation, Husky warrants that the product will be free from defects in materials and workmanship (if the installation date is in question or indeterminate, Husky will warrant the product for 12 months from sale by Husky). Husky confirms that the warranty is transferable to a subsequent purchaser within the warranty period. However, the warranty does not follow the product from its installation location to succeeding locations. Husky confirms these products are warranted to meet the performance standards and specifications to which it was certified by CARB for the duration of the warranty. EVR products must be installed per CARB Executive Order and must follow the Husky Installation Instructions or the warranty is void. The warranty tag included with the EVR product must be provided to the end user at installation. A completed warranty tag and installation documentation is required to be returned with the product to be eligible for warranty consideration.

CONVENTIONAL PRODUCTS – Husky Corporation will, at its option, repair, replace, or credit the purchase price of any Husky manufactured product which proves upon examination by Husky, to be defective in material and/or workmanship for a period of one (1) year from the manufacture date of shipment by Husky. Buyer must return the products to Husky, transportation charges prepaid. This Warranty excludes the replaceable bellows, bellows spring assemblies, spout assembly and scuff guard, unless (i) damage is obvious when the product is removed from shipping carton and (ii) the defective product is returned to Husky prior to use. This warranty does not apply to equipment or parts which have been installed improperly, damaged by misuse, improper operation or maintenance, or which are altered or repaired in any way.

The warranty provisions contained herein apply only to original purchasers who use the equipment for commercial or industrial purposes. There are no other warranties of merchantability, fitness for a particular purpose, or otherwise, and any other such warranties are hereby specifically disclaimed.

Husky assumes no liability for labor charges or other costs incurred by Buyer incidental to the service, adjustment, repair, return, removal or replacement of products. Husky assumes no liability for any incidental, consequential, or other damages under any warranty, express or implied, and all such liability is hereby expressly excluded.

Husky reserves the right to change or improve the design of any Husky fuel dispensing equipment without assuming any obligations to modify any fuel dispensing equipment previously manufactured.

3" to 2" ADAPTOR INSTALLATION INSTRUCTIONS

Part 005041

1. Visually inspect the o-ring and threads for chips, dirt & debris.
2. Apply fuel resistant pipe sealant to the 3 in / 76.2 mm NPT threads of the vent pipe.
3. Screw the P/V vent adaptor onto the vent stack and tighten firmly, approximately 20 - 50 lbf•ft / 27.1 - 67.8 N•m, but do not overtighten.
4. Install the P/V vent according to manufacturer's installation instructions.

TEST ADAPTOR INSTALLATION INSTRUCTIONS

Part 005426

NOTE: This adaptor is designed to fit on the inlet of the P/V Vent to allow for field and lab tests.

1. Screw P/V Vent adaptor into the P/V Vent valve until hand tight. Make sure the seal is compressed.
2. Place the P/V Vent valve and adaptor on a flat surface.
3. Attach a 3/16" / 4.7 mm hose (Tygon fuel tubing) from test apparatus to hose barb on the side of the adaptor.
4. After testing, remove hose from barb and remove adaptor from vent

TROUBLESHOOTING GUIDE

Pressure Decay Test Failure...	<ol style="list-style-type: none"> 1. Test vent to CARB TP201.1E. 2. Replace vent
For stations with ISD monitoring	
Vapor leak...	<ol style="list-style-type: none"> 1. Verify other equipment is not the cause. 2. Test vent to CARB TP201.1E 3. Replace vent.
Exceeds allowable system cracking pressure...	<ol style="list-style-type: none"> 1. Replace vent

GENERAL TECHNICAL DATA

Fuel Type	Test and warranty for gasoline and diesel fuel
Body	Sand cast aluminum
Screens	Stainless Steel 40 mesh
Seal	N trile Foam
Covers	Aluminum
Weight	1.2 lbs / 0.5 kg
Threads	2 in / 50.8 mm NPT
Case Quantity	20

Listings



CARB EVR Executive Order Numbers: VR-101, VR-102, VR-103, VR-104, VR-105, VR-401-B, VR-402-A, VR-301, VR-302



OPW 723V Pressure / Vacuum Vent Valve Installation and Maintenance Instructions

Please read these warnings and assembly instructions completely and carefully before starting. Failure to do so may cause product failure, or result in environmental contamination due to liquid leakage into the soil, creating hazardous spill conditions.

IMPORTANT: The OPW 723V Pressure/Vacuum vent is preassembled for your convenience and ease of installation. Check to make sure the unit is intact and undamaged and all parts have been supplied. Never substitute parts for those supplied. Doing so may cause product failure.

WARNING-DANGER: Using electrically operated equipment near gasoline or gasoline vapors may result in a fire or explosion, causing personal injury and property damage. Be sure that the working area is free from such hazards, and always use proper precautions.

Notice: OPW products must be used in compliance with applicable federal, state, and local laws and regulations. Product selection should be based on physical specifications and limitations and compatibility with the environment and material to be handled. All illustrations and specifications in this literature are based on the latest production information available at the time of publication. Prices, materials, and specification are subject to change at any time, and models may be discontinued at any time, in either case, without notice or obligation.

OPW STANDARD PRODUCT WARRANTY TAG

Notice: FlexWorks by OPW, Inc., VAPORSAVER™ and all other OPW products must be used in compliance with all applicable federal, state, provincial and local laws, rules and regulations. Product selection is the sole responsibility of the customer and/or its agents and must be based on physical specifications and limitations, compatibility with the environment and material to be handled. All illustrations and specifications in this literature are based on the latest production information available at the time of publication. Prices, materials and specifications are subject to change at any time, and models may be discontinued at any time, in either case, without notice or obligation.

OPW warrants solely to its customer (the initial purchaser and any subsequent purchasers within the warranty period) that the following products sold by OPW will be free from defects in materials and workmanship under normal use and conditions for the periods indicated:

PRODUCT	WARRANTY PERIOD
FlexWorks Primary Pipe	10 years from date of manufacture
All Products and replacement parts installed in the State of California Certified to California CP 201 and/or CP 206 Standards*	1 year from date of installation (proof of purchase from certified contractors/technicians required) OPW warrants ongoing compliance with the standards and specifications for the duration of the warranty period required by the State of California; this limited warranty is under the condition the equipment was installed and maintained by trained and certified contractors/technicians unless noted in Installation Manual.
All other Products and replacement parts	1 year from date of manufacture**

*Products certified to California CP-201 and/or CP-206 Standards have been factory tested and met all applicable performance standards and specifications and will have an OPW registration card enclosed/attached to the product.

OPW's exclusive obligation under this limited warranty is, at its option, to repair, replace or issue credit (in an amount not to exceed the list price for the product) for future orders for any product that may prove defective within the applicable warranty period. (Parts repaired or replaced under warranty are subject to prorated warranty coverage for remainder of the original warranty period). Complete and proper warranty claim documentation and proof of purchase required. All warranty claims must be made in writing and delivered during the applicable warranty period to OPW at OPW 9393 Princeton-Glen Dale Road Hamilton, Ohio, USA 45011, Attention: Customer Service Manager. No products may be returned to OPW without its prior written authority.

This limited warranty shall not apply to any FlexWorks or VAPORSAVER™ product unless it is installed by an OPW attested installer and all required site and warranty registration forms are completed and received by OPW within 60 days of installation. This limited warranty also shall not apply to any FlexWorks, VAPORSAVER™ or other OPW product unless all piping connections are installed with a nationally-recognized or state-approved leak detection device in each tank and dispenser sump (which are not for storage and from which all discharge hydrocarbons must be removed, and the systems completely cleaned, within 24 hours); unless testable sumps utilize FlexWorks pipe and access fittings; unless a sump inspection log or an EPA recommended/required checklist is maintained and the results are furnished to OPW upon request; and unless OPW is notified within 24 hours of any known or suspected product failure and is provided with un-

restricted access to the product and the site. This limited warranty also shall not apply to any product which has been altered in any way, which has been repaired by anyone other than a service representative authorized by OPW, or when failure or defect is due to: improper installation or maintenance (including, without limitation, failure to follow Flex-Works Quick Reference Manual Installation Guide and all product warning labels); abuse or misuse; violation of health or safety requirements; use of another manufacturer's, or otherwise unauthorized, substances or components; soil or other surface or subsurface conditions; or fire, flood, storm, lightning, earthquake, accident or any other conditions, events or circumstances beyond OPW's control.

THIS LIMITED WARRANTY IS IN LIEU OF ALL OTHER WARRANTIES, EXPRESS OR IMPLIED, AND ALL OTHER WARRANTIES INCLUDING, WITHOUT LIMITATION, THE WARRANTIES OF MERCHANTABILITY AND FITNESS FOR A PARTICULAR PURPOSE, ARE HEREBY EXCLUDED.

OPW shall have no other liability whatsoever, whether based on breach of contract, negligence, gross negligence, strict liability or any other claim, including, without limitation, for special, incidental, consequential or exemplary damages or for the cost of labor, freight, excavation, clean-up, downtime, removal, reinstallation, loss of profit, or any other cost or charges. No person or entity is authorized to assume on behalf of OPW any liability beyond this limited warranty. This limited warranty is not assignable.

**** Date of manufacture on this product is located on the top of the Valve.**

OPW 723V Series Performance Specifications:

This Pressure / Vacuum vent has been manufactured and tested to the following specifications: Pressure leak rate not to exceed 0.05 CFH at 2" W.C. Vacuum leak rate not to exceed 0.21 CFH at -4" W.C. The cracking pressure to be 2.5" to 6" W.C. and cracking vacuum to be 6" to -10" W.C. Tested using CARB Test Procedure TP-201.1E, TP-201.1E CERT, or applicable Phase I Executive Order.

Install vent per requirements in NFPA 30. Vents should be located so that vapors will not be trapped by eaves or other obstructions.

Torque Specification:

Vent Assembly 2" NPT, 35 ft lbs minimum to 55 ft lbs maximum.

OPW 723V PRESSURE / VACUUM VENT VALVE INSTALLATION INSTRUCTIONS:

Step 1:

Deburr and thoroughly clean vent pipe. **NOTE: Vent must be mounted vertically.** Apply pipe dope to vent pipe threads. Pipe dope to be a non-hardening, gasoline resistant pipe thread seal compound.

Step 2: (See Figure 1)

Screw the vent assembly onto the vent pipe and torque to 35 ft. lbs minimum to 55 ft-lbs maximum. Use the flats on the

pipe adaptor only, **Do not wrench on the composite valve assembly.**

NOTE: NEVER PAINT OR COVER THE VENT

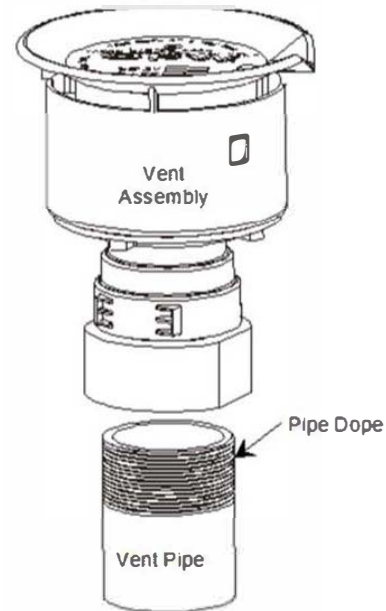

Figure 1

Operation and Maintenance:

Annual maintenance is required to keep the vent operating satisfactorily. Remove and inspect filter screens – clean or replace as necessary. Test as necessary.

Upper Screen Maintenance

1. Remove vent top by depressing tabs as indicated in Fig. 2, and lift top upward. Screen will slip up and out of valve.
2. Clean or replace filter screen (P/N 209817 for 723V) as necessary and reinstall Fig. 3.
3. Reinstall vent top by reinserting into the body. Be sure the tabs are inside the valve body, and then rotate top until the tabs snap into place.

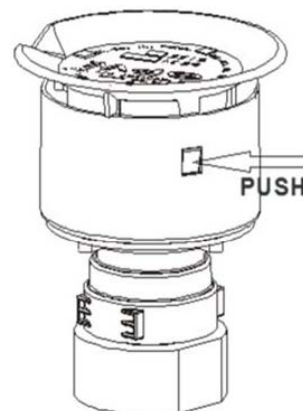
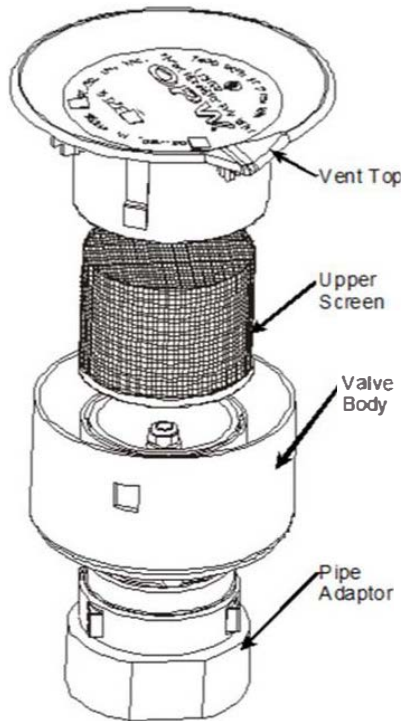
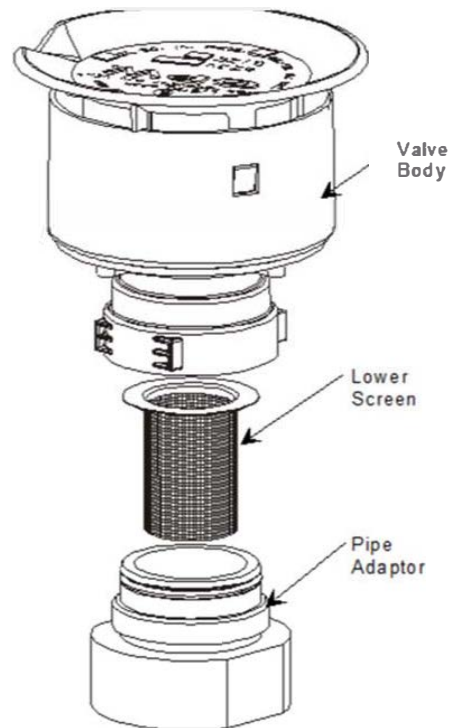

Figure 2



Manufacture Date "MM / YY"
MM = Month, YY = Year

Product Identification



Lower Screen Maintenance

Note: Do not remove the pipe adaptor from the vent pipe to service the lower filter screen.

1. Remove valve assembly from the pipe adaptor. Grip assembly at the flats just above the pipe adaptor and unscrew. (Fig. 4)
2. Lift the filter screen out and clean or replace (P/N C05086M) as necessary.
3. Reinstall filter screen in the pipe adaptor (see Fig. 4 for orientation).
4. Reinstall valve assembly on pipe adaptor and tighten until it stops. Do not wrench valve assembly except with smooth jaw wrench.

Valve Testing

If any issues are seen when testing using CARB Test Procedure TP-201.1E it is recommended to retest the valve using CARB Test Procedure TP-201.1E CERT. Ensure valve is mounted vertically.

IMPORTANT: Leave these instructions with Station Operator.

Figure 4



OPW Retail Fueling
3250 US 70 Business West
Smithfield, NC 27577
Customer Service: 1-(800) 422-2525
Technical Service and Questions:
1-(877) OPW-TECH
www.opwglobal.com

Part Number: 211276
Issue Date: 03-01-2016

Notice: OPW products must be used in compliance with applicable federal, state, provincial and local laws and regulations. Product selection should be based on physical specifications and limitations and compatibility with the environment and material to be handled. OPW makes no warranty of fitness for a particular use. All illustrations and specifications in this literature are based on the latest production information available at the time of publication. Prices, materials and specifications are subject to change at any time, and models may be discontinued at any time, in either case, without notice or obligation. For complete OPW warranty information, visit our web site at www.opwglobal.com.

Figure G-1
Veeder-Root P/N 312020-952 Tank Gauge Port Cap and Adaptor

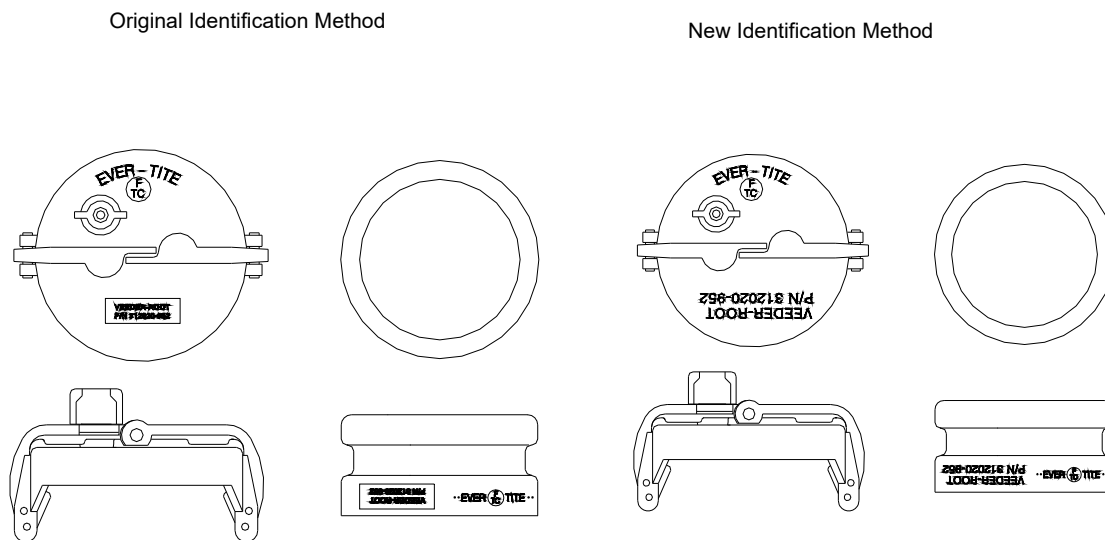

Installation Instructions

Install an ARB approved machined adaptor onto the riser. Apply a gasoline-resistant, non-hardening thread sealant to the threads of the riser adaptor only. Next screw the ring from the Veeder-Root kit (P/N 312020-952) onto the riser adaptor by hand until the gasket contacts the sealing surface. Then use a torque wrench attached to an appropriate strap wrench (K-D Specialty tools nylon strap oil filter wrench P/N 3149, or equivalent) and tighten the ring to 35-45 ft.-lbs. Loosen the cord grip nut and push the cable through the cap and cord grip, then clamp the cap onto the ring.

Figure G-2
Morrison Brothers Tank Gauge Port Components
305XPA & 305XPA1100AKEVR (cap and adaptor kit)
305 & 305-0200AAEVR (replacement adaptor)
305XP & 305XP-110ACEVR (replacement cap)

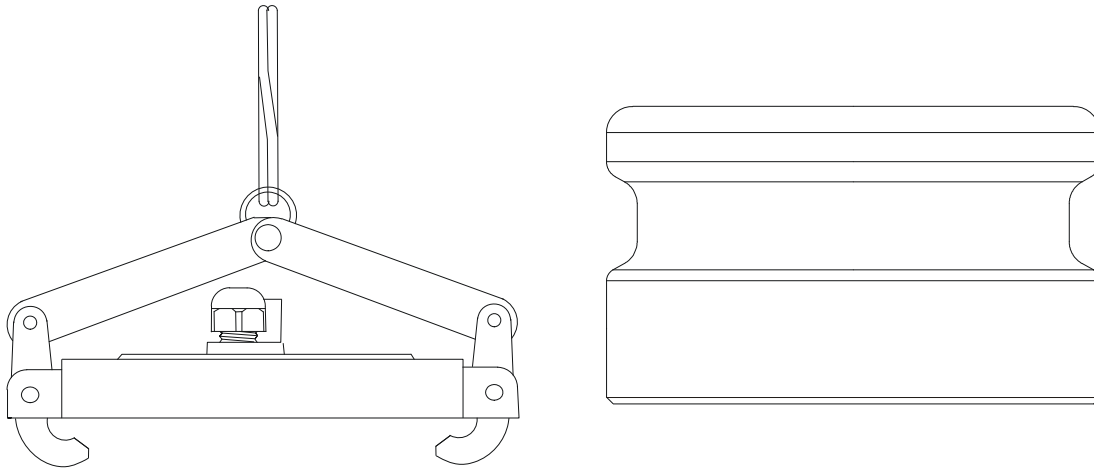

305XP Cap

Installation Instructions –

1. Apply a fuel resistant, non-hardening, anti-seize sealant (not adhesive) to cable connector threads. Follow manufacturer's instructions for installation of monitoring system.
2. Set cap on adaptor
3. Push down on lever arms.

305 Adapter

Installation Instructions –

1. Apply a fuel resistant, non-hardening, anti-seize sealant (not adhesive) to body threads.
2. Thread body on to riser pipe. Torque to 23-26 ft.-lb.

Figure G-3
EBW Tank Gauge Components
90037-E (cap and adaptor)

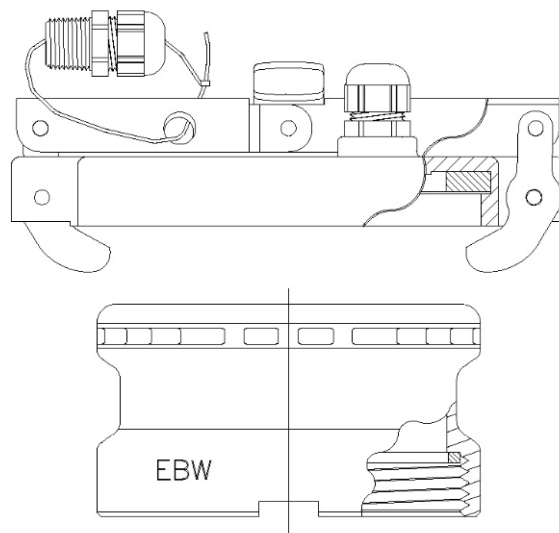

Annual maintenance of the probe riser cap assemblies is normally not required. Whenever probe service is necessary, inspect service cap seal for damage and replace, if necessary, at that time.

FIGURE H-1
Phil-Tite Phase I EVR
OPW 61-T Straight Drop Tube

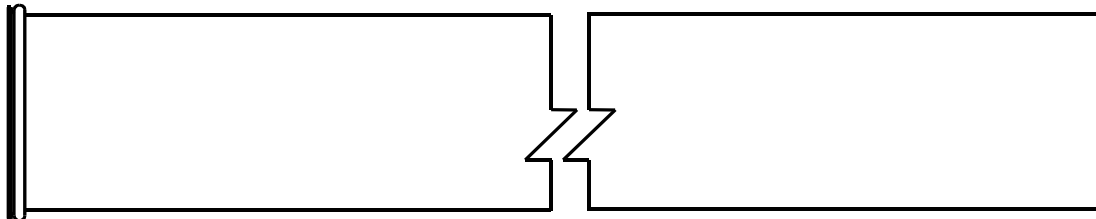

YOU MUST USE THE PHIL-TITE DROP TUBE SEAL (P/N 85039-DT).
DO NOT USE THE ROUND O-RING PROVIDED BY OPW.

Installation Instructions

1. Cut the tube to a length so that it is not more than 6 inches from the bottom of the tank. Saw off the excess tube at a 45-degree angle, or per local codes or requirements, and file off any sharp burrs.

Operation and Maintenance:

Annually: Test the drop tube seal with ARB procedure TP-201.1C or TP-201.1D. If the drop tube seal passes testing, no further maintenance is required. If the drop tube seal fails testing, replace the drop tube seal with Phil-Tite Drop Tube Seal (P/N 85039-DT) for 4 inch tubes. Re-test the drop tube seal with ARB procedure TP-201.1C or TP-201.1D.



Figure H-2
EBW 782 Straight Drop Tube

Installation Instructions

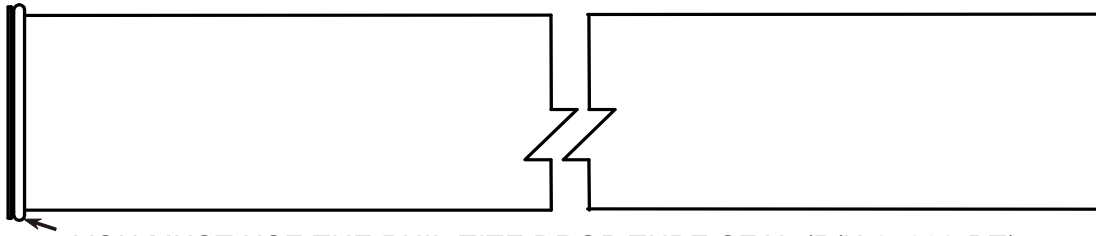

YOU MUST USE THE PHIL-TITE DROP TUBE SEAL (P/N 85039-DT).

1. Cut the tube to a length so that it is not more than 6 inches from the bottom of the tank. Saw off the excess tube at a 45-degree angle, or per local codes or requirements, and file off any sharp burrs.

Operation and Maintenance:

Annually: Test the drop tube seal with ARB procedure TP-201.1C or TP-201.1D. If the drop tube seal passes testing, no further maintenance is required. If the drop tube seal fails testing, replace the drop tube seal with Phil-Tite Drop Tube Seal (P/N 85039-DT) for 4 inch tubes. Re-test the drop tube seal with ARB procedure TP-201.1C or TP-201.1D.



Installation & Maintenance Instructions

FOR

**EBW 708-49X-1Y & 708-49X-3Y
Drop Tube Overfill Prevention Device
(Auto Limiter II®)**

IMPORTANT: Please read these assembly and installation instructions completely and carefully before starting.

THESE INSTRUCTIONS ARE VERY DIFFERENT FROM OTHER MANUFACTURERS INSTRUCTIONS AND REQUIRES THE UPPER DROP TUBE SECTION TO BE FLARED USING PHIL-TITE FLARING TOOL MODEL T-6100-FT

GENERAL INSTRUCTIONS

The EBW Auto Limiter II is designed for tight fill connections, gravity drop applications only, and to provide positive shut-off of product delivery before an overflow condition occurs without intervention from the transport driver (per EPA and State requirements). The valve features a sealed float pivot and a threaded lower tube connection with a maximum vapor leak rate of 0.17CFH @ 2" inches H₂O or less in accordance with CARB TP-201 1C or D

The EBW Auto Limiter II is designed to be installed in a spill container through a 4" schedule 40 tank riser.

It can be used with a Defender Series Spill Container, Phil-Tite Spill Container, or EBW Spill Container.

IMPORTANT

Read these assembly and installation instructions completely and carefully prior to starting. Check to make sure you have the special drop tube seal (85039-DT) and a package of JB KWIK. Do not use any substitutes for these items. The use of substitute parts may cause product failure.

Failure to follow these instructions may cause improper product operation or premature failures which may permit storage tank overflow. An overflowed storage tank may create hazardous conditions and/or environmental contamination.

WARNING

Failure to properly connect delivery hose and elbow, and/or disconnecting a liquid filled delivery hose or elbow will result in a hazardous spill, which may result in personal injury, property damage, fire, explosion, and water and soil pollution.

- Make sure all connections, including the hose and elbow connections between the storage tank and transport are securely coupled. Prefer the use of rotatable Fill and Vapor adaptors.
- Make sure the lip seal and/or all gaskets in the delivery elbows and adaptors are properly in place to prevent spills.

- Do not make a delivery using damaged or missing parts, which prevent tight connections.

Normal Operation of the over-fill valve: A Hose "Kick" and reduced flow signal that the tank has reached 92% full. Fuel flow is reduced by 90%. Close the transport delivery valve(s) and drain hose into tank before disconnecting any hose fitting. If delivery is not stopped and the liquid rises above 95% of tank capacity the EBW Auto Limiter II[®] valve will shut down the flow of fuel into the UST.

Overfilled Tank: The inability to drain the hose or failure of the hose to drain after closing the delivery valve(s) signals an overfilled tank. **Do Not Disconnect** any delivery hose fittings until the liquid level in the tank has been lowered to allow the hose to drain into the tank.

IMPORTANT

Determine if the underground storage tank is equipped with a ball float vent valve. In all systems, the shut-off point of the EBW Auto Limiter II[®] must be reached before the ball float reduces flow to ensure proper overflow valve operation.

TOOLS NEEDED FOR INSTALLATION AND ASSEMBLY:



- ¾" X 20' Tape measure
- High-Tension Hacksaw, with fine tooth (24-32 teeth/inch) blade or equivalent.
- Fine teeth half round file or de-burring tool
- Phil-Tite Flaring Tool Assy. (T-6100-FT)
- ¼" Ratchet with 3" extension
- 3/16" X 1/4" & 5/16" X 1/4" Hex with socket adaptor
- Small common screwdriver
- Fine Tip Marking pen (Sharpie) or pencil

If installed in a Defender Series Spill container, the drop tube flange is positioned inside the spill container, between the sealing ledge and DT Riser Clamp.

If installed in a Phil-Tite Spill Container, the drop tube flange is positioned underneath the spill container, between the and riser adapter (M/F 4X4).

If installed in an EBW Spill Container, a Drain Valve Isolation Kit is required for installation.

Underneath Fill Adapter
(EBW Legacy Series)

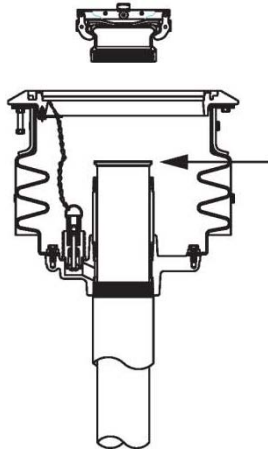

Underneath Bucket
(Phil-Tite Series)

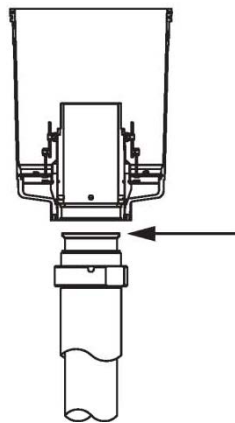

Inside Bucket
(Defender Series)

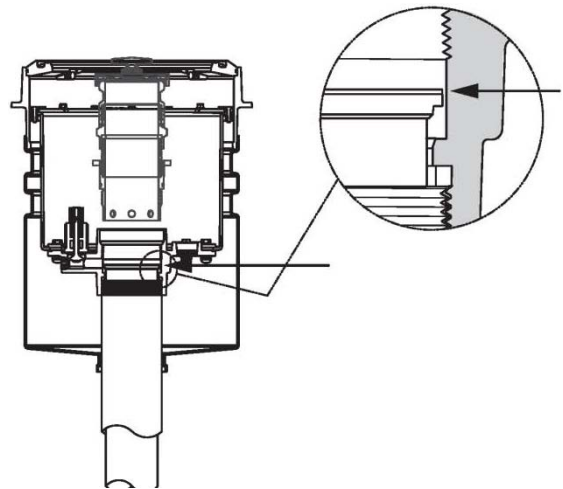

To determine the correct lengths to cut the upper and lower sections of the drop tube for installation; use the Work Sheet for Determining the Drop Tube Lengths that follows.

If installing into an EBW Spill Container, refer to the instructions that are supplied with the Drain Valve Isolation Kit.

FRANKLIN FUELING SYSTEMS

EBW Auto Limiter II® Drop Tube Overfill Prevention Device

Measurement Work Sheet for Determining the Drop Tube Lengths

Date: _____

Site Location:(name) _____ Installing Contractor:(name) _____

Address _____ Address _____

City/State _____ City/State _____

Contact/Phone _____ Contact/Phone _____

Tank Number: _____ Product: _____ Tank Type: _____

Tank Manufacture: _____ Tank Capacity _____

(from Mfg tank chart)

Tank Diameter *(from Mfg tank chart)* _____ inches

STEP 1 Determine the distance in inches Auto Limiter II® Automatic Shut-off valve must be set below the top _____ of the tank for it to close when the tank reaches 95% or less capacity.

Using the manufactures tank chart, find the tank total capacity in gallons. Multiply this number by 95% (0.95). If you want the shut off valve to close at less than 95% (i.e. 93% then use that percentage to multiply by the total tank capacity in gallons. _____

Total tank capacity in gallons (_____) X (0.95 or less) = _____ gallons _____

Using the manufacturer tank chart, convert the 95% or less capacity in gallons to inches = _____ inches

Use TABLE 1 to calculate the correct distance.

TABLE 1

Primary Tank Diameter in (inches) (_____)

Subtract the 95% Liquid level converted to inches - (_____)

This results is the distance in inches below the top of the tank

to the tank's 95% liquid level in inches = (_____)

Subtract 4 inches *(from the last value obtained above)* 4.00

This is "the distance" that the Auto Limiter II® Shut-off valve must be set below the top of the tank for the shut-off valve to operate correctly when the tank reaches 95% or less capacity: = (_____)

Transfer this number to Step 3 and Table 2 for determining the UPPER DROP TUBE LENGTH.

STEP 2 Determine the total height of the Fill (product) riser height with the M/F 4X4 riser adapter installed. See Figure 1, Measurement “A” (Note: Both the fill riser and M/F 4X4 riser adapter must be installed and correctly torqued.) To determine the fill riser height, (M/F 4X4 riser adapter must be installed if applicable) take a tape measure and measure from inside the installed fill riser, (hook the tape on the end of the riser or on the inside top of tank) and measure from the bottom end of the fill riser to the top of the M/F 4X4 threaded riser adapter installed on top of the riser

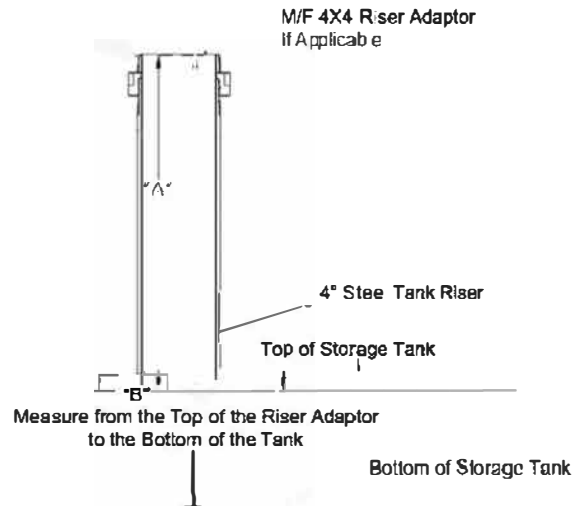

Figure 1

This is measurement “A” () inches

STEP 2a To determine the total drop tube length, take the tape measure and measure from inside the fill riser from the bottom of the tank to the top of the M/F 4X4 riser adapter.

This is Measurement “B”() inches (See Figure 1)

STEP 3 Determining the **Upper Drop Tube** Length above the automatic shut-off prevention valve. Use the final results in inches determined in **Step 1 ()** and **ADD it to measurement “A” from Step 2 ()** Go to Table 2.

TABLE 2

The final results from Step 1 ()
 Measurement “A” Step 2 ADD + ()
UPPER DROP TUBE LENGTH = ()

This is the exact length the top section of the aluminum drop tube should be above the automatic shut-off valve for this tank installation.

NOTE: If this UST has a manway and the fill riser is installed in the top of the manway you must add the height of the manway to your fill riser length “A” for the shut-off valve to be set the correct distance below the top of the tank. See the Flaring Tool instructions for cutting and flaring the upper drop tube.

Step 4 Determining the total length of the drop tube. After flaring the upper drop tube section take the results of measurement “B” in **Step 2a ()**, and **subtract 6 or less inches = ()**.

Starting at the flare end (upper section) measure the entire length of the drop tube from the top down to the bottom and mark this measurement near the bottom portion of the drop tube. This will be your cut line for the bottom portion of the drop tube. Go to Table 3

TABLE 3

Measurement “B” from Step 2a ()
 Less 6” inches or local regulatory amount ()
TOTAL DROP TUBE LENGTH = ()

Hint: Use 5 7/8 inches in lieu of 6 inches to ensure you do not exceed 6 inches. To make a perfectly straight cut follow the Flaring Tool instructions while using the flaring tool cutter to make this cut. Place the cutting blade directly on the marked cut line and make your cut.

STEP 5: MARKING FINAL CUT MARKS

Upper Drop Tube Length

Mark the upper tube length with the dimension found in Step 3 Table 2 from the Drop Tube work sheet. Measure the upper section of the drop tube with a tape measure from where it connects to the mechanical over-fill valve to the dimension from Table 2 "Upper Drop Tube Length". Mark the drop tube using a black fine point marker (Sharpie) or pencil. This will be the length of the upper drop tube section of the drop tube after flaring. See Step 5 Photo 1.

Rough Cut Length

Measure 2" to 2 1/2" inches further up the Upper Drop Tube Length and mark the drop tube using a black fine point marker (Sharpie). This will be your rough cut mark. See Step 5, Photo 2.

STEP 5 Photos 1 & 2 – Marking the Upper Drop Tube length and the rough cut mark

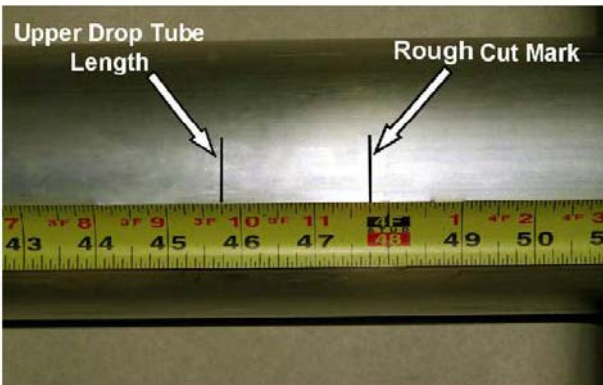
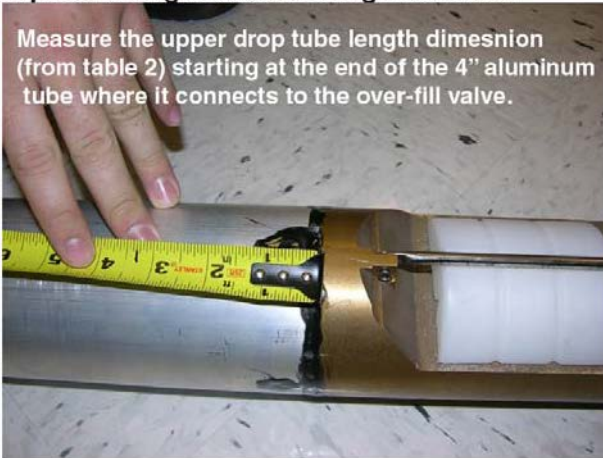

STEP 6: REMOVE EXCESS UPPER DROP TUBE – Rough Cut

Using a Hack Saw or SawsAll, saw through the Upper drop tube on the rough cut mark. This cut does not have to be straight. See Step 6 Photo

CAUTION - DO NOT use a pipe or tubing cutter to cut the upper drop tube, this may damage the tube, causing it to be out of round.

STEP 6: Photo – Performing the rough cut.



STEP 7: INSTALL THE DRIVE RING

Position the Drive Ring with the alignment markings facing forward on the upper drop tube length mark, marked in Step 5. There should be approximately 1" - 3" inches of excess upper drop tube beyond the Drive Ring. See next two following photos.

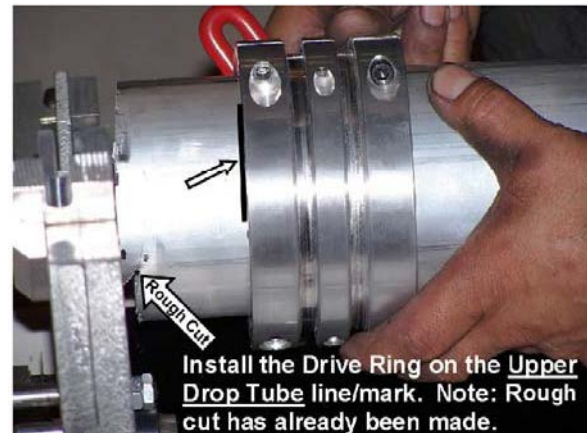

STEP 7 Cont.

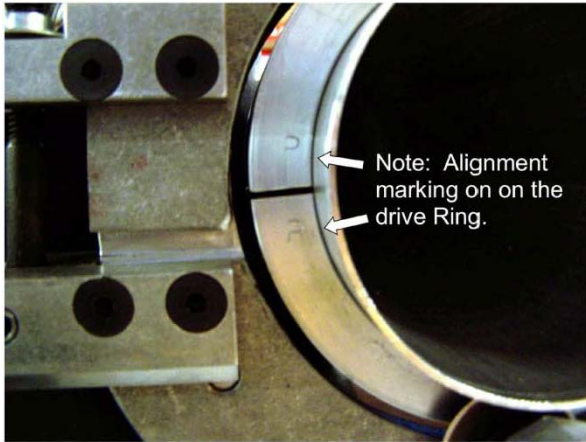

STEP 8: TIGHTEN THE DRIVE RING

Alternately Tighten the 4 Hex Screws on the Drive Ring. Check that the drive ring is still on the mark made for the drop tube Upper Drop Tube Length found in Step 3. See photo below:



STEP 9: POSITION THE DRIVE RING IN THE FLARING TOOL

Position the Upper Drop Tube with the Drive Ring into the Flaring Tool. See Photo Below:



STEP 10: SECURING THE DRIVE RING IN THE FLARING TOOL

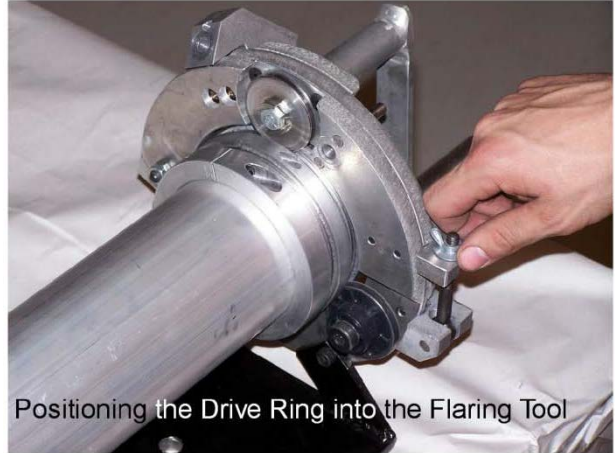

Use the wing nut to tighten the Drive Wheel into the drive ring groove just enough to create a light tension between the drive wheel and drive ring (**do not over tighten**). See Photo below:

STEP 11: PERFORMING the PRECISION CUT

Apply light hand pressure on the cutter handle and rotate the drop tube to cut the proper dimension. **Do not apply excessive pressure.** Should the drop tube not turn, tighten the thumb-screw tension until the handle drives the drive ring.

After the drop tube is cut there should be 1/4" inch of material remaining. See Photo below.

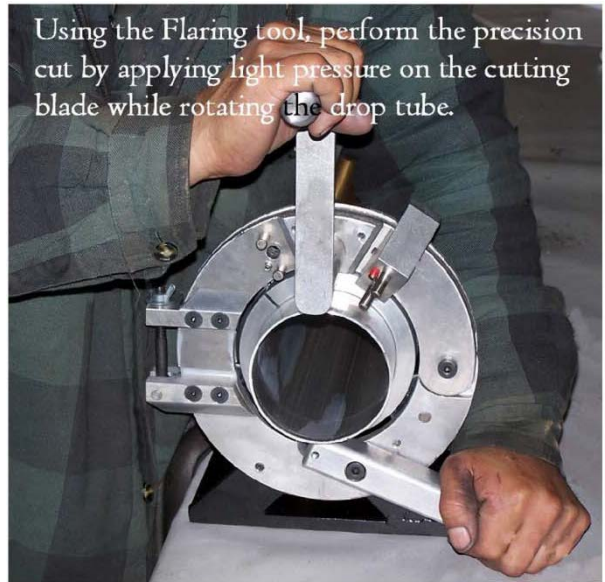

After making the precision cut, remove any burrs on the inside of the drop tube using a fine tooth file or de-burring tool. You are now ready to start performing the 0 – 45 degree flare.

STEP 12: FIRST FLARING ROLLER POSITION

The first position for the flaring roller is in the 0 – 45 degrees position. Use the long hex screw to connect the flaring roller to the flaring tool. See the following two photos below for correct position.

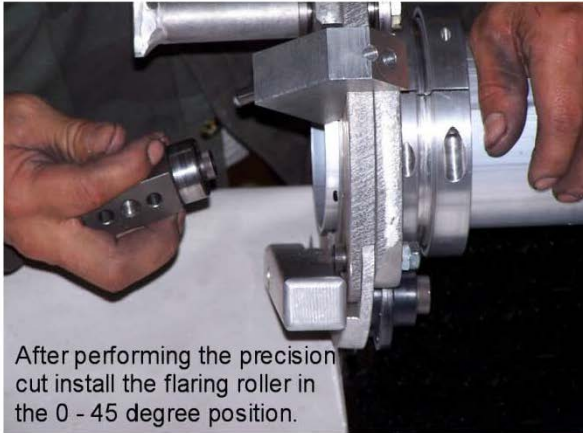

After performing the precision cut install the flaring roller in the 0 - 45 degree position.

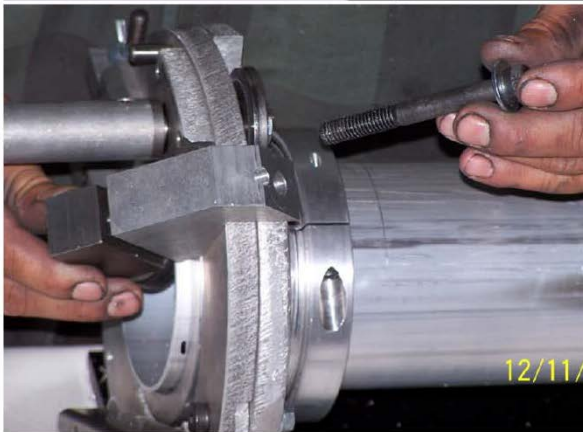

STEP 13: PERFORMING 0 – 45 DEGREE FLARE

Turn the long hex screw until it is snug. While turning the Flaring Tool Handle, slowly tighten the long hex screw applying continual pressure until a 45 degree flare is made. The hex screw will bottom out and become tight. When this happens stop turning the long hex screw, the first half of the flare is complete. Remove the long hex screw and Flaring roller.

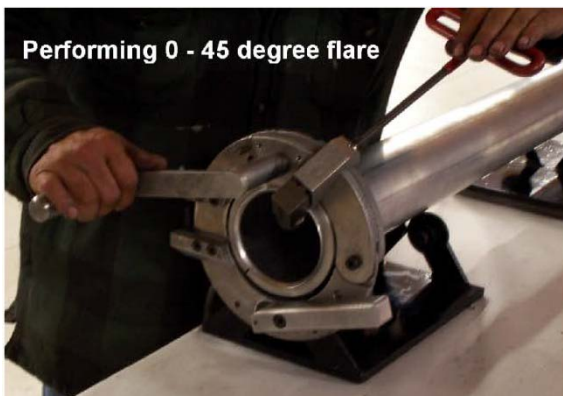

STEP 14: 45 – 90 DEGREE FLARING POSITION

Install the flaring roller in the 45 – 90 degree position using the short hex screw. See photo below.

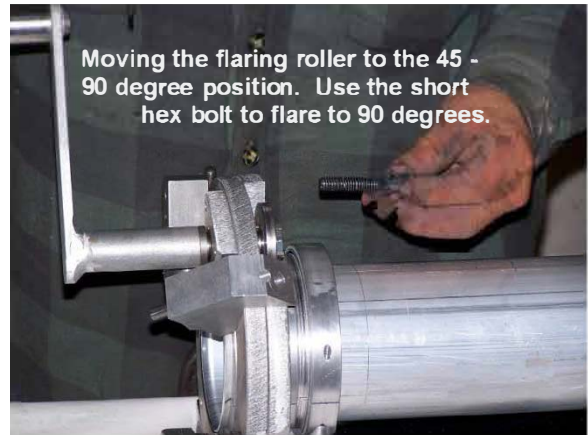

STEP 15: PERFORMING - 45 – 90 DEGREE FLARE

Turn the short hex screw until it is snug. While turning the Flaring Tool Handle, slowly tighten the short hex screw applying continual pressure until the 90 degree flare is completed. The short hex screw will bottom out and become tight. When this happens, **STOP** turning the short hex screw, the 90 degree flare is complete. Remove the short hex screw and flaring roller. See photo below.



STEP 16: FLARE COMPLETED

After the flaring procedure is completed, there should be smooth, flat 90-degree flare. Remove the flaring roller from the flare tool and the drive ring from the drop tube. See Photo below.



STEP 17: CHECK YOUR FLARE MEASUREMENT

Measure the upper drop tube for the correct length. The Upper Drop tube mark should be at the base of the flare. See Photo Below.



STEP 18: INSTALLING THE DROP TUBE SEAL

Install the Phil-Tite Special Designed Drop Tube Seal (85039-DT) onto the drop tube with the flat side up against the drop tube flare. See Photo Below.

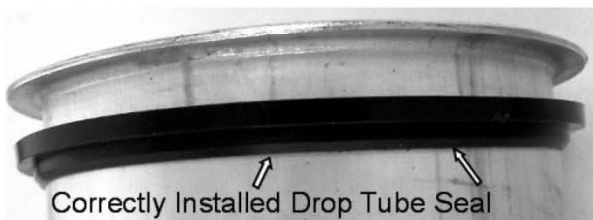

STEP 19: INSTALLING LOWER DROP TUBE ASSEMBLY

If a vise is used, clamp on the valve body casting only to avoid damage to the float. Mix the two-part J-B Kwik provided until the color is uniform. Using a mixing stick, **generously apply J-B Kwik to the first 6 male threads on the valve body** as shown in Figure 2. Make sure coverage is completely around the threads, and work the sealant down into the thread profile. Quickly thread the lower tube onto the valve body. Tighten the tube securely by hand or with a strap wrench. Remove excess sealant and smooth sealant bead with water moistened mixing stick.

Important: Allow sealant (J-B Kwik) to cure for a minimum of 4 hours before installing the drop tube assembly into a tank with fuel.

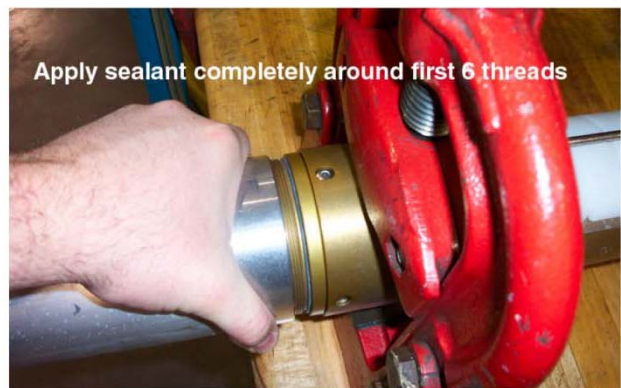

Figure 2

Note: After the sealant (JB Kwik) has cured and before installing the drop tube into the tank, a pressure test can be performed on the valve to check for vapor tightness. Seal off both ends of the tube with inflatable plumber's plugs. Apply a maximum 10" inches W.C. (1/3 PSI) air pressure. If pressure does not hold and a leak can be located with soap solution, do not install the valve. Send the valve back to FFS/ Phil-Tite for warranty evaluation.

Caution: Do not over-pressurize. Excess pressure can damage the valve.



STEP 20: CUTTING LOWER END OF DROP TUBE

Measuring from the underside of the inlet tube flange, mark the overall length of the drop tube a distance of (B) minus 6" inches or as per local codes or requirements. Determine dimension (B) from the Drop Tube Measurement Worksheet taken in Step 3, Figure 1 (Top of the FFS M/F 4 X 4 Riser Adaptor to the bottom of the tank). Saw/Cut off the excess tube and file off any sharp burrs.

Optional: Install the Philtite Tank Bottom Protector on the lower tube (Refer to Installation instructions supplied with the Tank Bottom Protector).

STEP 21: PREPARE TANK RISER FOR OVERFILL VALVE INSERTION

IMPORTANT: Inspect the tank riser pipe for any foreign material. Over spray from tank relining or any internal burrs inside of pipe must be removed prior to installation. Failure to have an unobstructed tank riser pipe may prevent proper installation or operation of the valve. Thoroughly clean top of tank riser pipe.

Important: Before installing the drop tube, allow the sealant to cure for minimum of 4 hours.

STEP 22: INSPECT AUTO LIMITER II

Check the exposed floats for freedom of movement. If floats drag, inspect guide bar for damage. Both of the floats should be free to move up and down without drag.

STEP 23: INSTALL THE DROP TUBE

Make sure the special drop tube seal (85039-DT) is installed correctly. Slowly insert the drop tube into the tank riser pipe. Do not force the valve into the tank riser pipe. If any obstruction or foreign matter interferes with smooth insert on of the valve, the tank riser pipe must be cleared.

WARNING

Failure to follow the assembly and installation instructions or use of excessive force to insert the Auto Limiter II® will "VOID THE WARRANTY!"

STEP 24: FINAL INSTALLATION**Phil-Tite Spill Container:**

Install Spill Container according to the manufacturer's installation instructions. Ensure that the drop tube does not rotate while tightening the Spill Container by observing the position of the deflector.

Defender Series Spill Container:

Install the DT Riser Clamp on top of the drop tube flange and tighten per the spill container installation instructions.

STEP 25: INSTALL WARNING PLATE

Install the warning plate in the location shown below the three access doors. See Figure 6 for the location of the warning plate.

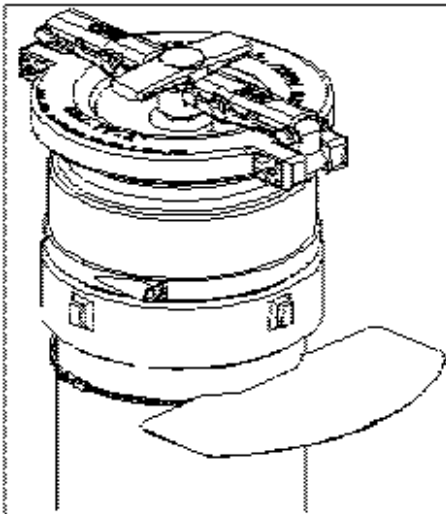

Figure 6

PREVENTATIVE MAINTENANCE

The EBW Auto Limiter II® maintenance section. Be sure to fill out the EWR Equipment Warranty form (F-3352) and send it to FFS/Phil-Tite within 30 days of installation. Failure to do so will void the warranty. Annual visual inspection of the installed drip tube for water build-ups.

CAUTION: Do not insert any foreign object into the drop

the valve and the alarm. ALWAYS check the alarm position before checking the tank. If valve is in the closed position the tank is either over filled and you need to wait until the liquid level goes out of the EBW Auto Limiter II is damaged and needs to be replaced.

EBW Auto Limiter II® Performance Specifications:

These will prevent that valve was in any failure by FFS and has been tested by FFS to meet the

low specification. The maximum leak rate does not exceed 17 DPH at 250 PSI. The maximum flow rate according with OARS TP-201 10 or D.

Important: Leave these installation instructions

and maintenance procedures with the station

operator.

Upper Drip Tube: Aluminum

Lower Drip Tube: Aluminum

Flanges: Di-Cast Zinc (anodized)

Float: Polyethylene



Defender Series™

Overfill Prevention Valve

Automatic Shutoff for USTs

Installation, Operation and Maintenance

708-590 Series





For use in 4" (102 mm) gravity-fill applications only
25-370 GPM (94-1400 LPM) flow
Compatible with all motor fuel blends

Important Safety Messages

Franklin Fueling Systems (FFS) equipment is designed to be installed in association with volatile hydrocarbon liquids such as gasoline and diesel fuel. Installing or working on this equipment means working in an environment in which these highly flammable liquids may be present. Working in such a hazardous environment presents a risk of severe injury or death if these instructions and standard industry practices are not followed. Read and follow all instructions thoroughly before installing or working on this, or any other related, equipment.

As you read this guide, please be aware of the following symbols and their meanings.

Warning  This symbol identifies a warning. A warning sign will appear in the text of this document when a potentially hazardous situation may arise if the instructions that follow are not adhered to closely. A potentially hazardous situation may involve the possibility of severe bodily harm or even death.

Caution  This is a caution symbol. A caution sign will appear in the text of this document when a potentially hazardous environmental situation may arise if the instructions that follow are not adhered to closely. A potentially hazardous environmental situation may involve the leakage of fuel from equipment that could severely harm the environment.

Warning  Follow all applicable codes governing the installation and servicing of this product and the entire system. Always lock out and tag electrical circuit breakers while installing or servicing this equipment and related equipment. A potentially lethal electrical shock hazard and the possibility of an explosion or fire from a spark can result if the electrical circuit breakers are accidentally turned on during installation or servicing. Please refer to the *Installation and Owner's Manual* for this equipment and the appropriate documentation for any other related equipment for complete installation and safety information.

Warning  Before entering a containment sump, check for the presence of hydrocarbon vapors. If these vapors are inhaled they could cause dizziness or unconsciousness, and, if ignited, hydrocarbon vapors could explode causing serious injury or death. Electronic and electrical petroleum monitoring equipment is often housed in containment sumps designed to trap hazardous liquid spills and prevent contamination of the environment, and, as a consequence, containment sumps can trap dangerous amounts of hydrocarbon vapors. If these vapor levels reach unsafe amounts, ventilate the sump with fresh air. While working in the sump, periodically check the atmosphere in the sump, if vapors reach unsafe levels, exit the sump and ventilate it before continuing work. Always have a second person standing by for assistance when working in, or around, a containment sump.

Warning  Follow all federal, state, and local laws governing the installation of this product and its associated systems. When no other regulations apply, follow NFPA codes 30, 30A, and 70 from the National Fire Protection Association. Failure to follow these codes could result in severe injury, death, serious property damage, and/or environmental contamination.

Warning  Always secure the work area from moving vehicles. The equipment in this manual is usually mounted underground, so reduced visibility puts service personnel working on this equipment in danger from moving vehicles entering the work area. To help eliminate these unsafe conditions, secure the area by using a service truck to block access to the work environment, or by using any other reasonable means available to ensure the safety of service personnel.

Caution Use only original FFS parts. Substituting FFS parts may cause failure of the device, which, in turn, may create a hazardous condition and/or damage the environment.

Contents

Important Safety Messages 2
 Introduction 3
 Determining Drop Tube Length 4
 Marking and Cutting the Tubes 5
 Completing the Installation 7
 Maintenance 8
 Overfill Prevention Valve Inspection 8
 Inspecting / Verifying 9
 Dimension Drawing 10
 Specifications 10
 Installation Record Sheet 11

Introduction

FFS's model 708-590 Series Overfill Prevention Valve should only be installed in a spill container through a 4" (102mm) schedule 40 tank riser. The valve is designed with a primary shutoff that will activate between 85 and 92% of tank volume, depending upon tank size. After the primary shut-off is actuated the flow through the valve is limited to less than 8 gpm (30 lpm). A secondary, positive shutoff will occur at 95% tank volume if filling continues. After primary shutoff occurs, the delivery hose may still be drained by using extreme caution, and taking these steps:

- Close the truck bottom loading valve. Wait 5 minutes
- Crack open the coupler between the delivery hose and the bottom loading valve, to allow the hose to drain slowly.

Note: Shutoff points are influenced by the specific gravity of stored liquids. These instructions are based on average performance using all products. *This valve was designed to be used as an emergency overfill prevention device only!*

Note: Determine if the underground storage tanks is equipped with a ball float vent valve. If the tank is equipped with a ball float vent-valve, the nipple portion must not extend more than 3" (76.2mm) into the tank for this device to function properly.

Caution  To prevent product spillage from an underground storage tank (UST), well-maintained delivery equipment, a proper connection, and a tight fill adaptor are essential. Delivery personnel should inspect delivery elbows and hoses for damage and missing parts.

Caution  The Overfill Protection Valve uses a strong magnet. Do not allow the Valve near a person with a pacemaker or similar medical aid. The strong magnetic field of the magnet can affect the operation of such medical devices.

Caution  Discharge to ground before putting into service and ensure valve is properly grounded while in service.

Caution  When inserting the drop tube/Valve assembly into the tank riser pipe, use caution not to forcefully impact the tank riser pipe. When raising/lowering the drop tube/ valve assembly while inside the tank riser pipe, do so in a slow, controlled manner.

Caution  It is the responsibility of the end user of this product to evaluate each installation location for the following potential ignition sources: Radio waves, ionizing radiation and ultrasound sound waves. If any of these potential ignition sources are identified, protective systems/measures shall be implemented.

Tools Needed for Installation and Assembly

- Tape Measure
- Half Round File
- Permanent Marker
- * FFS Pipe Cutter
- * Groove Roller Tool

Packing List

- (1) Valve Assembly
- (1) Installation Manual
- (1) Gasket – Upper Drop Tube (4")
- (1) Hose Clamp
- (1) Warning Plate

* Refer to the Product Catalog for ordering information.

Determining Drop Tube Lengths

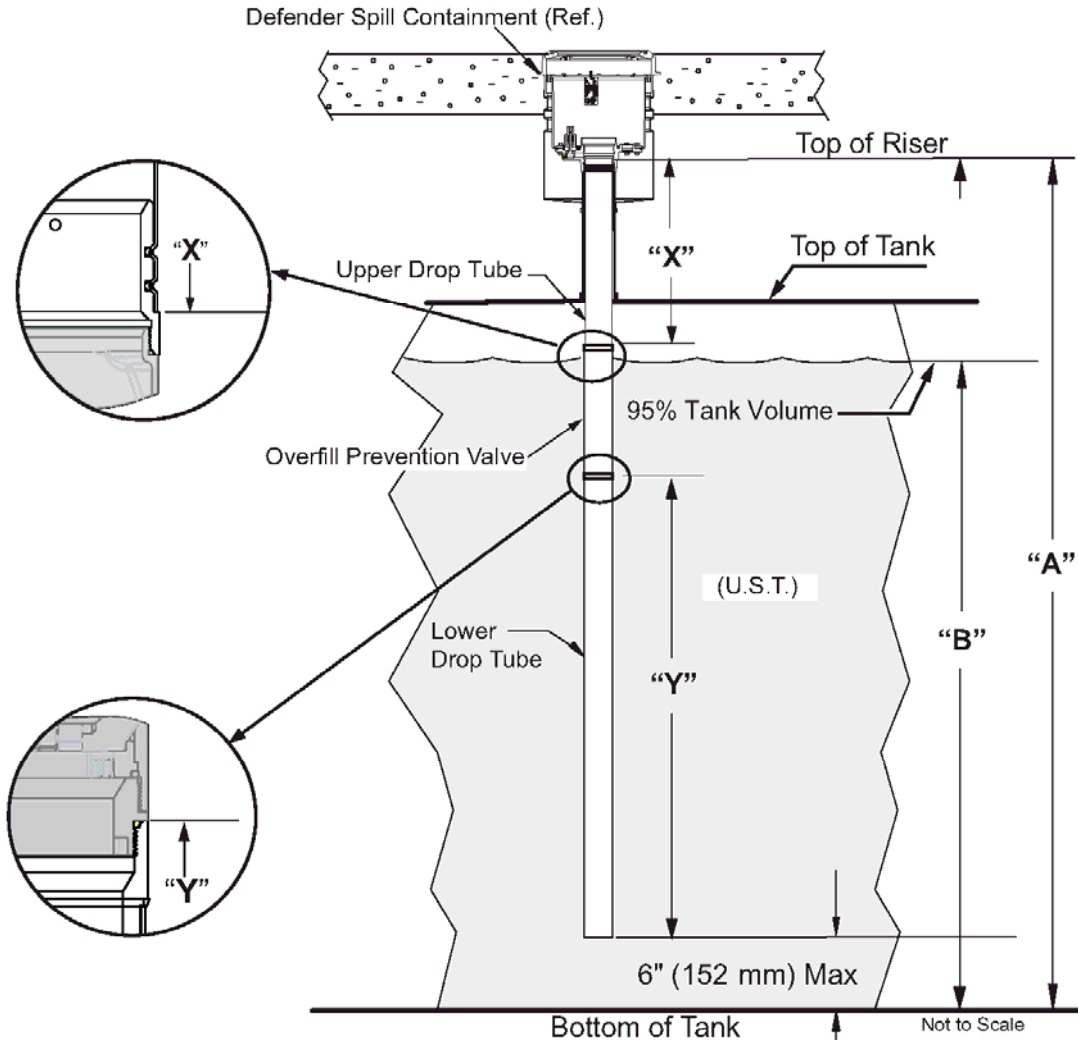

If local codes require this distance to be smaller, subtract less than 6" (152mm)

Figure 1: Installation Overview and Drop Tube Calculation

To find 95% Tank Volume and Measurement From Tank Chart

Actual Tank Capacity
 Gallons

X
 .95

=
 Gallons
 (95% Tank Volume)

95% Volume Height
 = B

<p>To find Upper Drop Tube length "X"</p> <p>"A" <input type="text"/> " Top of riser to bottom of tank</p> <p>- (subtract)</p> <p>"B" <input type="text"/> " 95% Volume height</p> <p>- (subtract)</p> <p><input type="text"/> 2 1/2" (63.5 mm) Position and mounting adjustment</p> <p>= (equals)</p> <p>"X" <input type="text"/> Upper Drop Tube Length</p>		<p>To find Lower Drop Tube length "Y"</p> <p>"B" <input type="text"/> " 95% Volume height</p> <p>- (subtract)</p> <p><input type="text"/> 15 3/4" (400 mm) OPV Length Offset</p> <p>- (subtract)</p> <p><input type="text"/> 6" (152mm) Tank bottom clearance</p> <p>= (equals)</p> <p>"Y" <input type="text"/> Lower Drop Tube Length</p>	
---	--	--	--

Explanation of Figure 1 Dimensions

- A** • Distance from the seat surface of the upper drop tube to the bottom of the underground storage tank. The seat surface will vary depending on the type of installation (see Figure 2).
- B** • 95% tank volume – obtained from the tank chart provided by the tank manufacturer. To find the 95% tank level on the tank chart, multiply the actual tank capacity by .95. Then find on the tank chart the level measurement that matches the calculated volume the closest.

Note: If local codes allow the positive shutoff level to be different from 95%, the installing contractor may adjust the "B" dimension per the tank chart to achieve the desired level.

Note: If tank tilt is an issue, the installing contractor may use best judgment to adjust "B" dimension accordingly, so "... none of the fittings located on top of the tank are exposed to product due to overfilling," per EPA 40CFR280.

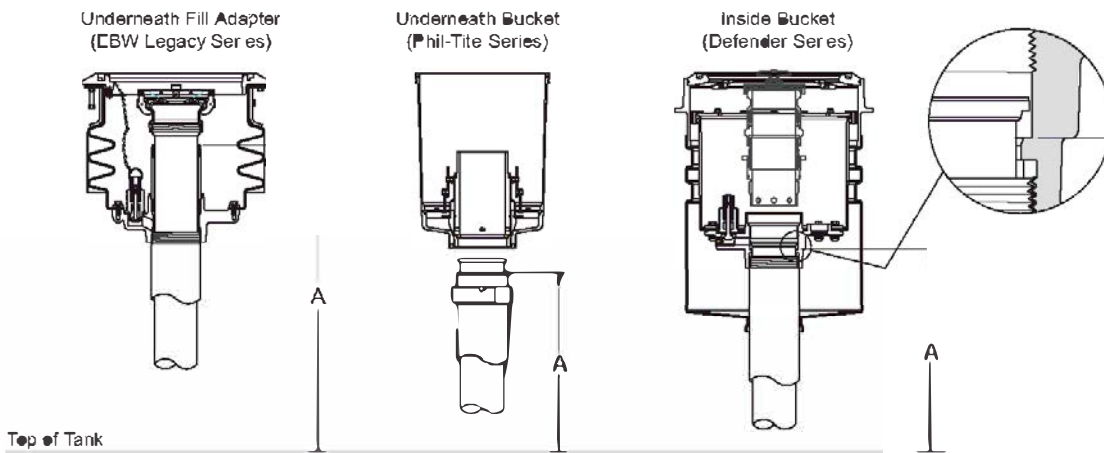

Figure 2: Installation Dimensions per Spill Container

MARKING & CUTTING THE TUBES

1. Mark the upper drop tube with the length "X" calculated from Figure 1, measuring per Figure 3:

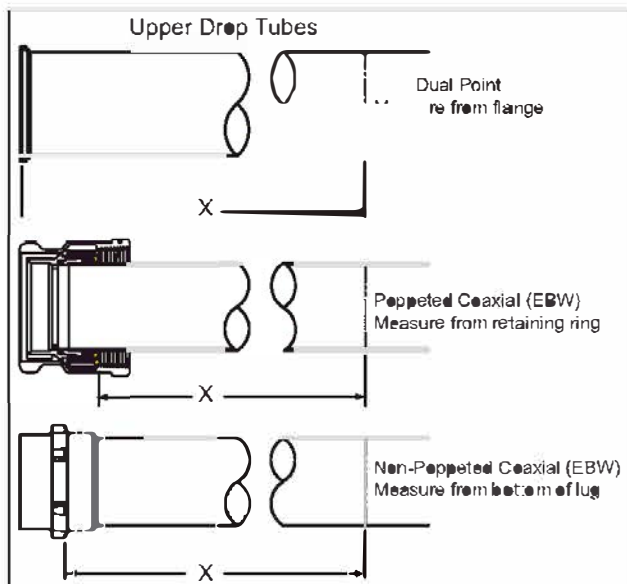

Figure 3: Dimension X for Upper Drop Tube

2. Mark the lower drop tube with the length "Y" calculated from Figure 1.

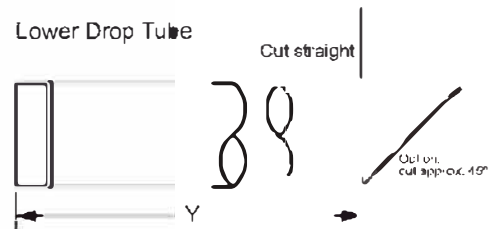

Figure 4: Lower Drop Tube

3. Cut the upper drop tube where marked, using the Franklin Fueling Systems pipe cutter.
 - a. If using the Franklin Fueling Systems Pipe Cutter, tighten the handle in very small increments (<math><1/10</math> turn per every 2 rotations of the tool).
To get the cut started and keep the cutter from "walking", tighten the blade against the tube just enough to make contact. Then rotate one full turn in one direction.
Next, rotate one full turn in the opposite direction. Tighten the cutter approximately $1/10$ th of a turn and repeat until a good scribe line is created. Overtightening the cutter wheel will result in crimping of the aluminum tube, which will cause the end to be too small for the adapter to fit inside.
 - b. If using a metal cutting saw blade, make sure to cut as squarely as possible. Using the band clamp supplied with the warning tag as a guide will aid in cutting squarely.
4. Using the half-round file, deburr the inside of the tube. Check to see if the upper tube adapter fits inside the upper drop tube – if not, more deburring may be needed.
5. Cut the lower drop tube as marked, using the FFS pipe cutter or a saw with a metal cutting blade.
 - a. If cutting the lower drop tube at a 45 degree angle, make sure the lowest point of the drop tube does not project within the minimum clearance specified by the tank manufacturer (or per local requirements).

Installing the Upper Tube Adapter

1. Replace the cutting wheel on the Franklin Fueling Systems Pipe Cutter with the Roller Tool (Figure 5)

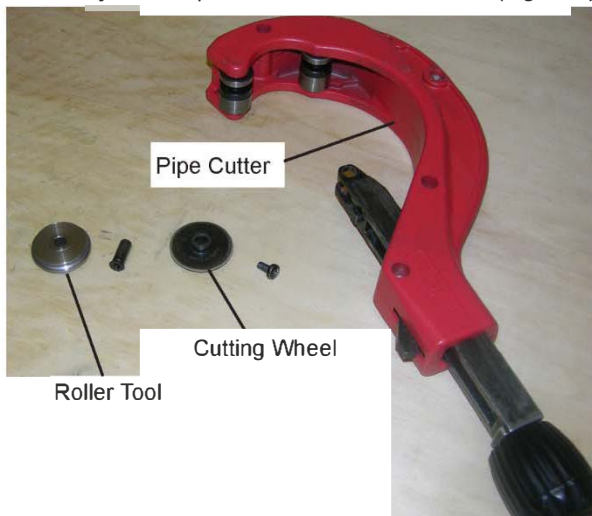

Figure 5: Pipe Cutter and Roller Tool

2. From the cut end of the upper drop tube, mark the grooves on the tube (Figure 6)



Mark Location on Drop Tube

Figure 6: Mark the Drop Tube

3. Install the drop tube gasket onto the upper drop tube (Dual Point Installation, Figure 7).



Figure 7: Drop Tube Gasket Installed

4. Check to make sure the O-rings are installed on the upper tube adapter.
5. Insert the upper tube adapter into the cut end of the upper drop tube.
6. Position the Roller Tool over the mark and lightly tighten.
7. To get the cut started and keep the roller from "walking", tighten the roller against the tube just enough to make contact. Then rotate one full turn in one direction and then rotate one full turn in the opposite direction. Tighten the roller approximately $1/10$ th of a turn and repeat until the groove is complete.

The tube is indented enough when the shoulder of the roller tool contacts the tube and creates a witness line/mark

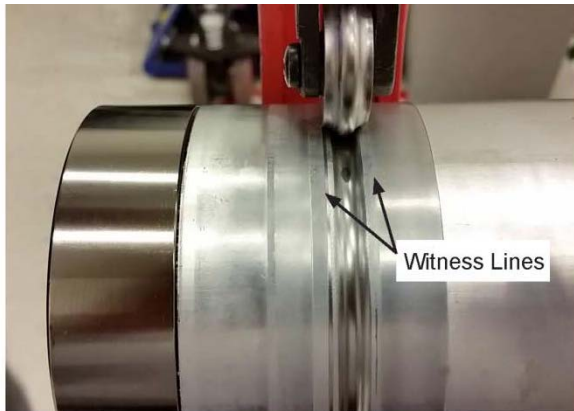

Figure 8: First Indent

8. Repeat steps 6 & 7 for the second mark



Figure 9: Second Indent

Completing the Installation

Before you begin assembly, clear the inside diameter of the tank riser pipe of any burrs, improper reaming, or foreign material. Failure to adequately clean the inside of the tank riser pipe may damage or prevent the valve from functioning properly.

Note: The upper and lower threads of the valve come pre-lubricated from the factory. **DO NOT USE PIPE SEALANT.** Verify the O-rings are present and not damaged

1. Thread the upper and lower drop tubes onto the Overfill Prevention Valve and tighten using strap wrenches (DO NOT USE PIPE WRENCHES). Position one on the upper drop tube, and the other on the lower drop tube (see Figure 11). DO NOT TIGHTEN ON THE FLOAT SHIELD OR VALVE.
2. Check the float and flapper mechanism by rotating the outer coupler (counter-clockwise). This should activate the internal flapper and operate smoothly. (Figure 10)

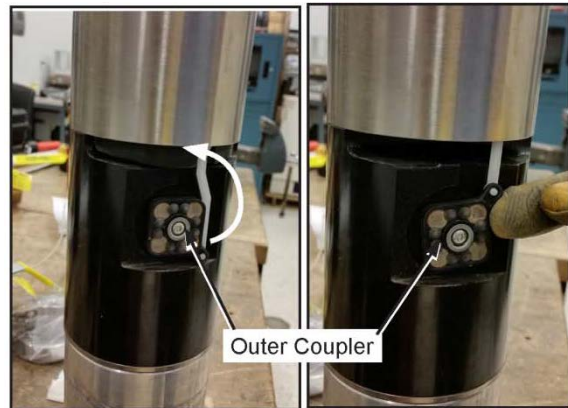

Figure 10: Outer Coupler, Lowered and Raised

3. Double-check to see that the drop tube gasket was installed under the upper drop tube flange (dual point installation, Figure 7).
4. Before inserting drop tube into the riser pipe, dissipate any static buildup by grounding to earth.
5. Carefully lower the completed assembly down the riser pipe (DO NOT DROP). Do not force the valve down the riser pipe. If the valve does not fit, the riser pipe may have to be cleaned or deburred further.



Figure 11: Do Not Tighten on the Float Shield

5. Reinstall the spill bucket components.
6. Install the warning plate around the 4" (102 mm) riser pipe below the threaded portion using the stainless steel band clamp (see Figure 12).



Figure 12: Install Warning Plate

7. Perform Operational Inspection Procedure.

Operational Inspection Procedure

The valve can easily be inspected by use of the Franklin Fueling Systems remote test tool.



Figure 13: Inspection Tool

Procedure

1. Assemble the remote test tool with enough extension sections to reach the Overfill Prevention Valve.
2. Insert the remote test tool into the drop tube. You should feel a "pull" when the magnets are positioned correctly and attract.
3. Slowly raise the remote test tool about 1 1/2" (38mm) and you should see the flapper move into the flow path.

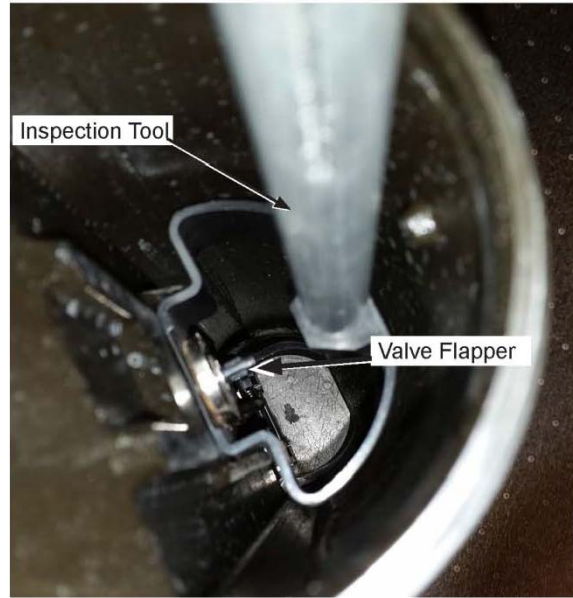

Figure 14: Valve Inspection, Flapper In

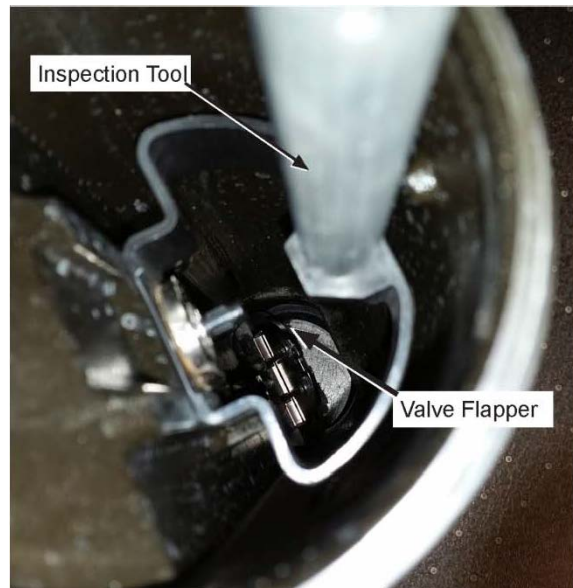

Figure 15: Valve Inspection, Flapper Out

4. If the flapper is observed moving back and forth, the valve is functioning normally.

Note: If required by local agency, a non-sparking stick/rod no larger than .750" (19 mm) dia may be inserted through the remote test tool opening to push flapper to the fully closed position.

5. To remove the remote test tool, simply pull out of the drop tube. The magnets will disengage and the flapper should reset automatically.

Maintenance

The 708-590 Series Overfill Prevention Valve has no periodic maintenance requirements.

However, if the drop tube and valve assembly is removed from the tank (for inspection or service), inspect the droptube seal for wear/damage (Figure 16). Replace if necessary.



Figure 16: Inspect Gasket

Additionally, if the upper or lower drop tube is unthreaded/removed from the OPV the O-ring(s) should be replaced (Figure 17).

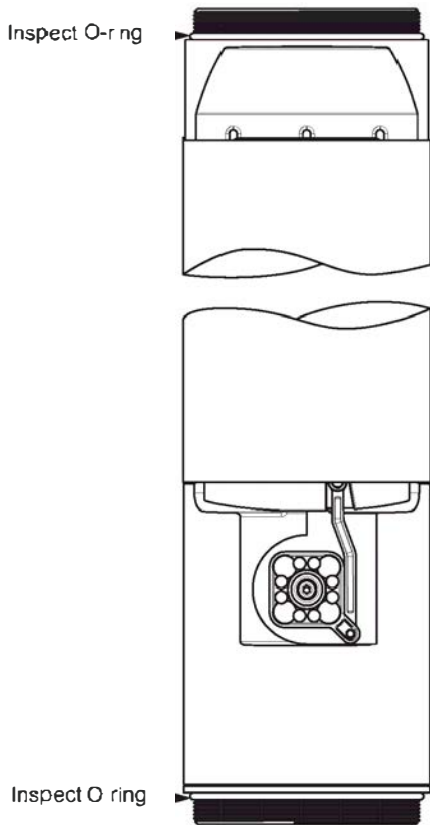

Figure 17: Inspect O-Rings

Inspecting/Verifying 95% Level (Without Removing from Tank)

FOR DIMENSIONS "A" & "B": Refer to the "installation record sheet" or re-measure and re-calculate per figure 1.

1. Measure Dimension "Z" (Figure 18)

"Z" $\left[\begin{array}{l} \text{Upper drop tube flange to} \\ \text{edge of upper tube adapter} \end{array} \right]$

2. Verify using the calculation below

"A" $\left[\begin{array}{l} \text{Drop tube seal surface to} \\ \text{bottom of tank} \end{array} \right]$

- (Subtract)

"B" $\left[\begin{array}{l} \text{95\% Volume from tank chart} \end{array} \right]$

- (Subtract)

$\left[4.5" (114\text{mm}) \right]$ (95% Shutoff level offset)

= (Equals)

Same value as "Z" indicates correct installation

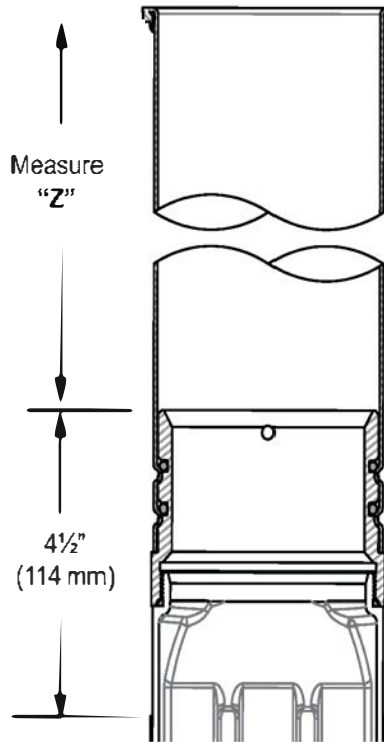
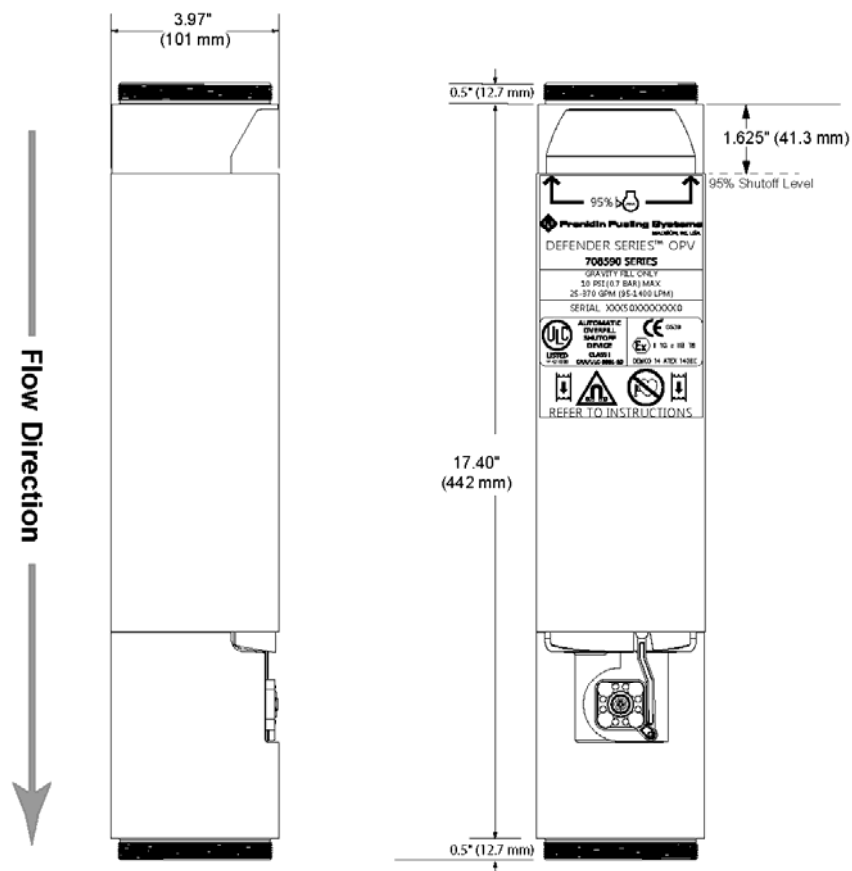
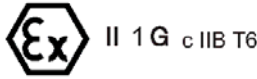



Figure 18: Dimension Verification After Installation

Dimension Drawing



Certification Information

ULC	File MH 21090, 1:1	
ATEX	 DEMKO 14 ATEX 1428X	
Florida	EQ-838	

Product Specifications

Construction	
Valve Body	E-Coated Cast Aluminum
Upper Drop Tube	Aluminum or Hard Coat Anodized Aluminum
Lower Drop Tube	Aluminum or Hard Coat Anodized Aluminum
Internal Mechanism	Nickel plated Aluminum, Stainless Steel, Acetal

Overfill Prevention Valve Installation Record Sheet

Date Installed

Valve Serial Number

_ 5 0 _ _ _ _ _ _ _ 0

Site information

Site # / Description _____

Site Address _____

Site Contact _____

Installing Contractor

Name _____

Company _____

Tank Information

Product Type _____

Underground Tank Manufacturer _____

Tank Full Volume _____

Tank Diameter _____

Tank Chart Available? Yes No

Tank Type Steel Fiberglass

Square Cylinder Dome Ends

Tank have compartments? Yes No

Tank/Drop Tube Measurements

Upper Drop Tube Length (X) _____ **Dimensions**

Lower Drop Tube Length (Y) _____ **A** _____

Distance from Lower Drop tube to tank bottom _____ **B** _____

Operational Inspection Procedure Performed

Yes

No

Initials

Date

Franklin Fueling Systems • 3760 Marsh Rd • Madison, WI 53718 USA

Tel: +1 608 838 8786 • 800 225 9787 • Fax: +1 608 838 6433 • www.franklinfueling.com

Figure-J-1
Phil-Tite TBP-3516 Series Tank Bottom Protector

INSTALLATION INSTRUCTIONS

Introduction:

All Underground Storage Tanks are required to have wear plates (striker plates) installed, center to center, below all accessible openings. A drop tube-mounted Tank Bottom Protector meets this requirement. UST's that DO NOT have metal striker plates manufactured into the primary tank bottom under all accessible openings must use a drop tube-mounted tank bottom protector in the fill opening. Tank bottom protectors help prevent damage and/or leakage in the primary tank caused by manual tank gauging during fluid level measurements.

Phil-Tite Enterprises Tank Bottom Protector is designed to fit inside the bottom of any 4" drop tube that is installed a maximum of 6" from the bottom of the tank. The bottom of the tank bottom protector has a rubber (Buna) pad to absorb the shock of the tank measuring stick when dropped into the tank. Above the rubber pad is a stainless steel wear plate that the tank measuring stick contacts at the bottom of the tank. This wear plate prevents the tank measuring stick from damaging the bottom of the primary tank that can cause leakage of product into the environment. To prevent the tank bottom protector from falling out of the drop tube during installation and removal of the drop tube, a stainless steel cable is attached from the tank bottom protector to the bottom of the drop tube.

Installation:

Step 1 - Drop tube preparation - Ensure your drop tube bottom section has been cut to the correct length per state and local regulations and is a maximum of 6" from the bottom of the tank.

Step 2 - Using a No. 20 drill bit (0.161"), drill a hole 1/4" - 3/8" from the bottom edge of the drop tube. If the bottom is cut at an angle, drill this hole midway up the slope. See Figures 1 & 2.

Step 3 - Install (slide) the tank bottom protector into the bottom section of the drop tube leaving approximately 6" - 7" exposed from the bottom of the drop tube.

Step 4 - Using a pop rivet gun, install the 5/32" aluminum pop rivet through the cable eyelet into the hole drilled in the bottom section of the drop tube.

Step 5 - Check that the pop rivet and cable eyelet are secure and flush against the drop tube outer wall. See Figure 2.

Step 6 - You are now ready to install the drop tube into the tank.

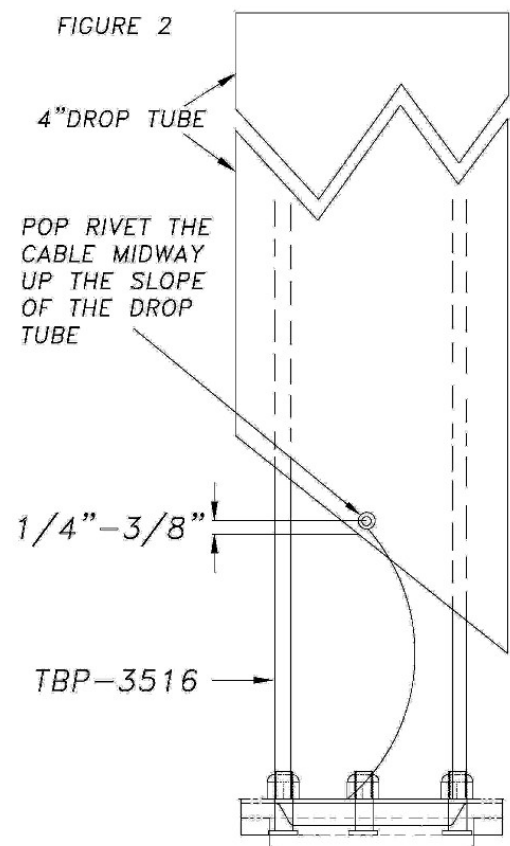
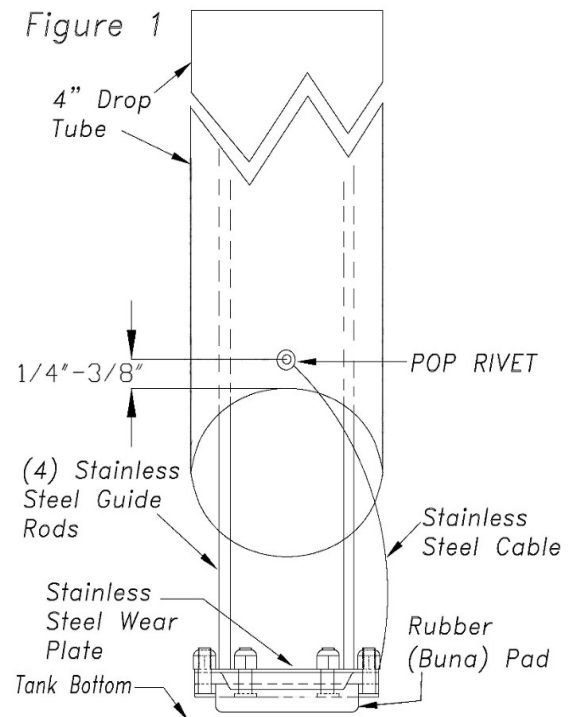
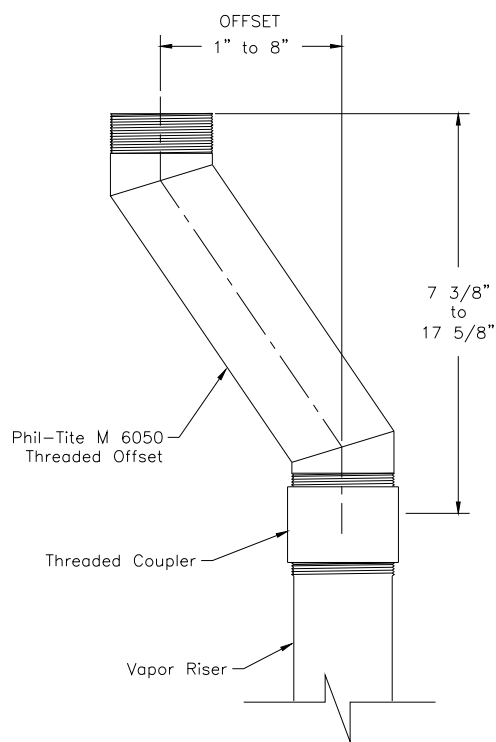
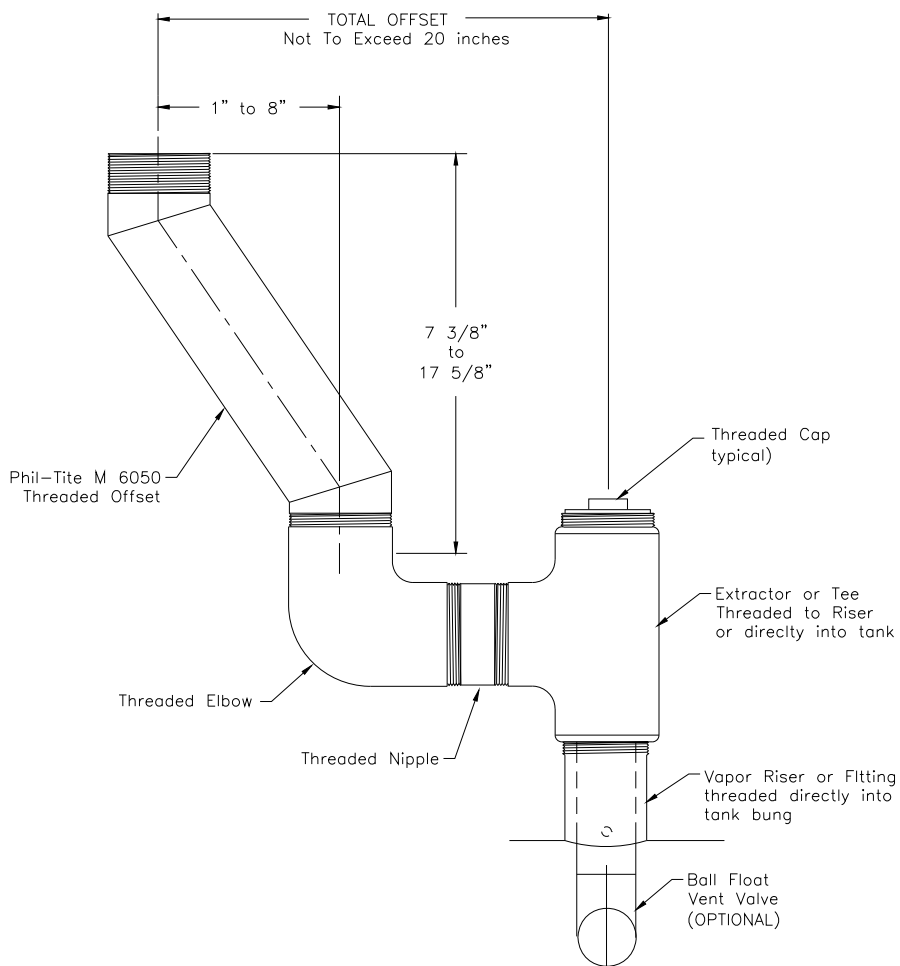

Figure K-1
Phil-Tite Model M-6050 Vapor Recovery Riser Offset Examples

Offset Using Straight Riser



Offset Using Ball Float



Note: This figure represents one instance where a vapor recovery riser has been offset in order to construct a two-point Phase I vapor recovery system. The above figure illustrates an offset using a 90-degree elbow. However, in some instances, elbows less than 90 degrees may be used. All fittings and pipe nipples shall be 4-inch diameter similar to those of the spill container and rotatable Phase I adaptors in order to reduce back pressure during a gasoline delivery.

Figure K-2
Phil-Tite Model M-1600 Riser Support Bracket Installation

PHIL-TITE ENTERPRISES
RISER SUPPORT BRACKET
PART NO. M-1600
Use in Multi-Port Configuration

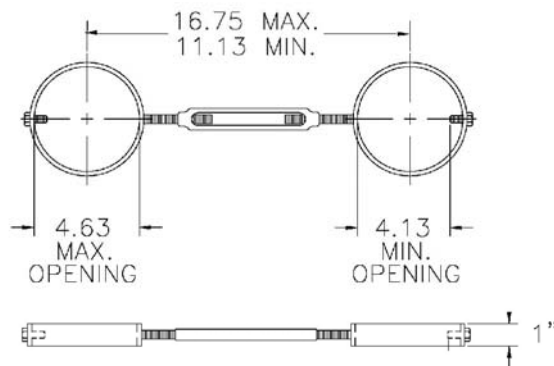

THIS DRAWING SHOWS BASIC FILL & VAPOR RECOVERY
 RISER SUPPORT BRACKET. ALL DIMENSIONS CAN BE
 ALTERED TO SUIT VARIOUS INSTALLATION CONDITIONS.

—CAUTION—

THIS DEVICE IS STRICTLY TO KEEP RISERS
 AT THE SPECIFIED BUNG SEPARATION DIMENSION
 NOT TO CHANGE BUNG SEPARATION DIMENSION
 MAXIMUM DEFLECTION IS 1" EITHER DIRECTION.

(Continued on next page.)

continued

Franklin Fueling - Phil-Tite M-1600 (EVR) Tank Riser Support Bracket Installation Instructions

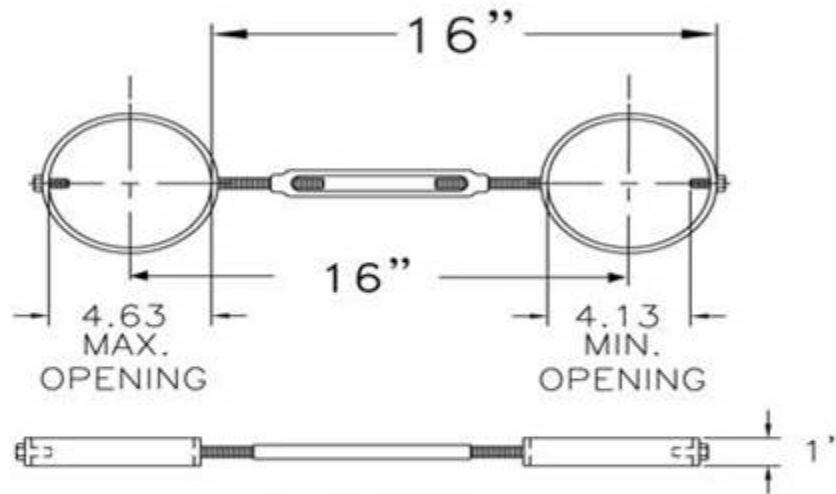

—CAUTION—

THIS DEVICE IS STRICTLY TO KEEP RISERS AT THE SPECIFIED BUNG SEPARATION DIM., NOT TO CHANGE BUNG SEPARATION DIM. MAXIMUM DEFLECTION IS 1" EITHER DIRECTION.

Installation - Multiport - Install the Riser Support Bracket over the Fill and Vapor risers before installing the M/F 4X4 Riser Adaptors. Adjust the turn buckle to ALIGN the Fill and Vapor Risers to 16" on center. See above Figure.

Figure K-2 continued

M-1600 RISER SUPPORT BRACKET

Mandatory For Multiport Spill Buckets Installations – To Align The Tank Risers

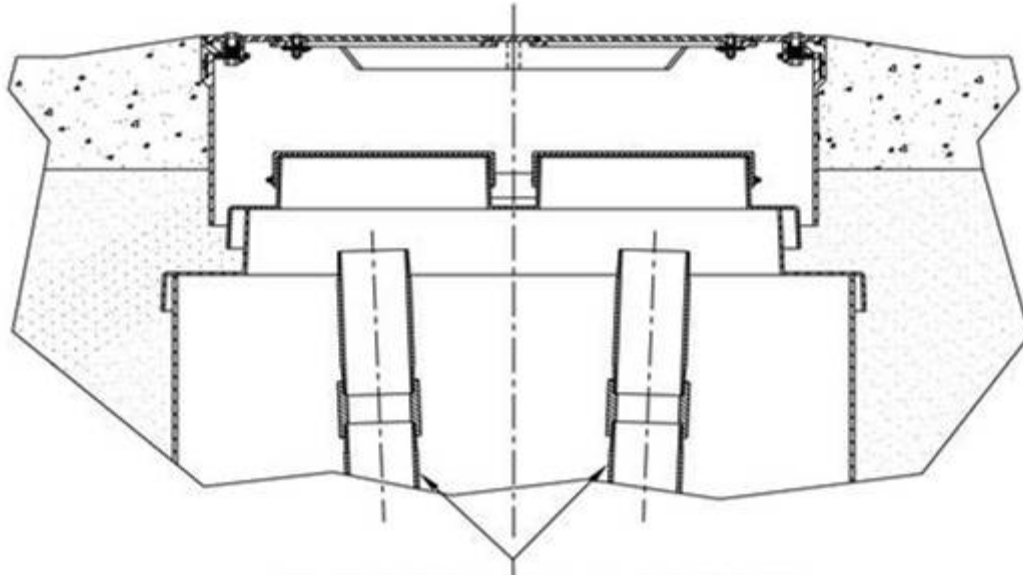

TANK RISERS OUT OF ALIGNMENT
ALIGNMENT MUST BE SET 16" ON CENTER

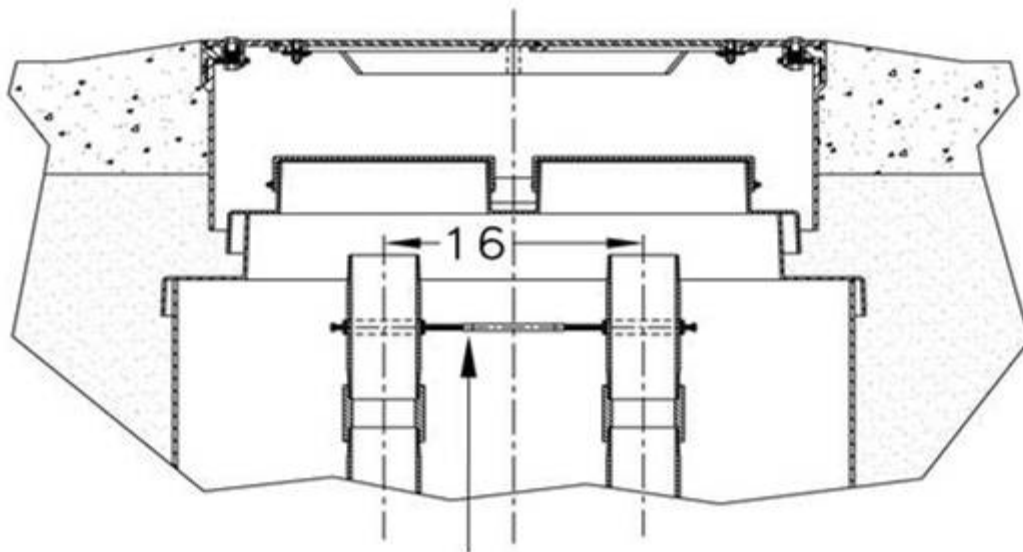

ADJUST SUPPORT BRACKET TO
PROVIDE PROPER ALIGNMENT OF
TANK RISERS (16" ON CENTER) JUST
BELOW THE M/F 4X4 RISER
ADAPTORS AND/OR SPILL BUCKETS.

Figure L-1
Typical Phil-Tite Double Fill Configuration

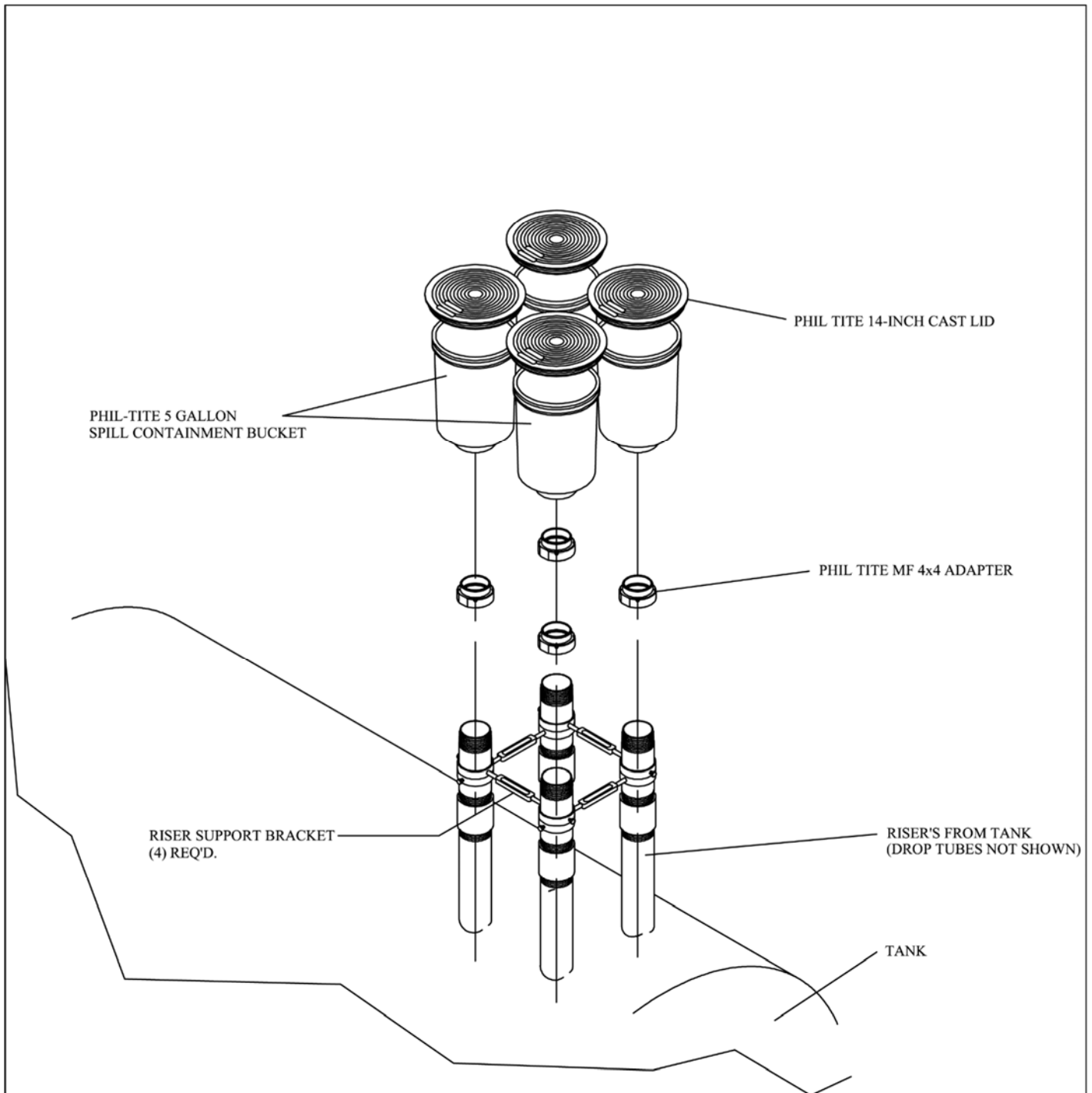

Figure L-2
Franklin Fueling Systems - Phil-Tite
T-7043 / T-7043-1 Phase I Installation & Removal Tool Kit
(See Figure L-3a on next page.)

(Note: T-7043-1 INCLUDES THE GREEN TORQUE TESTING ADAPTOR)

- T-7001** **TEE HANDLE ASSEMBLY – 2 PARTS – FITS ALL TOOL ADAPTORS** (With the exception of the green torque testing adaptor)
- T-7100** **RED ADAPTOR – USED TO REMOVE OLD NON-SWIVEL FILL ADAPTORS**
- T-7002-A** **BLACK ADAPTOR – (HEAVY DUTY) - USED TO INSTALL AND REMOVE PHIL-TITE BLACK SPILL CONTAINERS** (Replaces T-7101 non-heavy duty adaptor)
- T-7102** **ORANGE ADAPTOR – USED TO INSTALL AND REMOVE THE M/F 4X4 RISER ADAPTOR, AND FILL & VAPOR SWIVEL ADAPTORS**
- T-7103** **BLUE ADAPTOR – USE TO REMOVE AND INSTALL OPW's TALL SWIVEL ADAPTOR**
- T-7104** **GREEN ADAPTOR – USED WITH A 3/8" DRIVE DIAL INDICATING TORQUE WRENCH TO TEST THE STATIC TORQUE OF THE SWIVEL ADAPTOR'S TOPS**

Figure L-4
Franklin Fueling Systems Defender Series Spill Container Installation Tools

- T-7106** **Double-Ended Installation Tool – Designed for use with Defender Series spill containers**
- T-7107** **Double Wall Vacuum Test Kit – Designed for use with Defender Series spill containers, double wall models only.**

Defender Series Spill Container Installation Tools

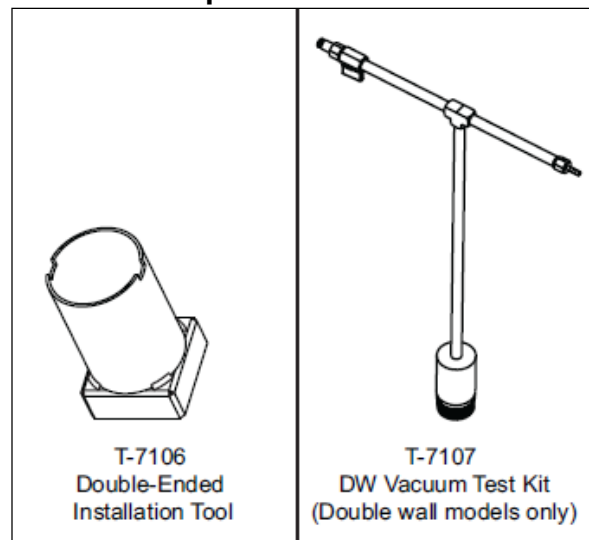

Figure L-3
Figure of T-7043 Toolkit

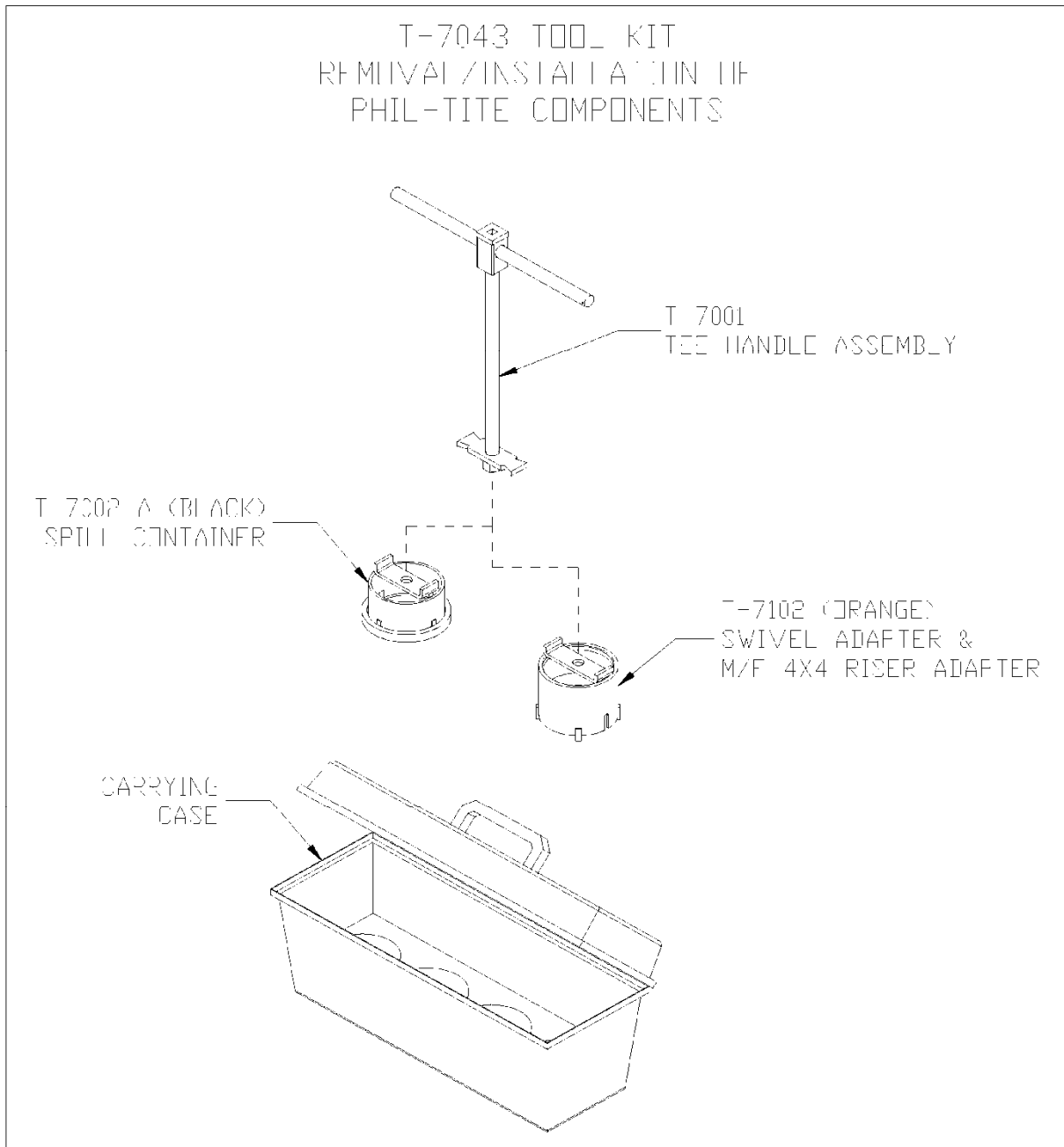

Figure M-1: Defender Series Spill Container Single Wall Configuration Installation, Operation, and Maintenance Instructions



DEFENDER SERIES™

5 Gallon, Single Walled, Field Replaceable Spill Container

Model 705-540 Series

INSTALLATION, OPERATION, & MAINTENANCE



Franklin Fueling Systems • 3760 Marsh Rd. • Madison, WI 53718 USA
Tel: +1 608 838 8786 • 800 225 9787 • Fax: +1 608 838 6433 • www.franklinfueling.com

Contents

Component and Subassembly Illustrations.....3
 Replacement Parts..... 3-4
 Preparation.....5
 New Site/Retrofit Site5
 Overview Diagram.....6
 Installation..... 7-8
 Integrity Testing8
 Spill Container Subassembly Replacement.....9

Tools Required

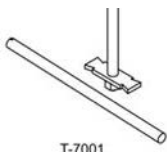

T-7001
T-Handle Wrench



T-710R
Double-Ended
Installation Tool

- 1/2" Socket or Nut Driver
- 1/2" Drive Torque Wrench
- Silicone based O-ring lubricant or silicone spray
- NON-HARDENING thread sealant approved for gasoline/oil service

Torque Specifications

Location	Ft-lbs (N-m)
Spill Container to UST Riser Pipe	125-150 (170-203)
Drop Tube (DT) Riser Clamp to Spill Container	75-100 (102-136)

Cautions / Warnings

Warning Follow all federal, state and local laws governing the installation of product and its associated systems. When no other regulations apply, follow

NFPA codes 30, 30A and 70 from the National Fire Protection Association. Failure to follow these codes could result in severe injury, death, serious property damage and/or environmental contamination.

Warning Always secure the work area from moving vehicles. To help eliminate unsafe conditions, secure the area by using a service truck to block access to the work environment, or by using any other reasonable means available to ensure the safety of service personnel. The Defender Series Spill Containment is used with tanks containing gasoline or other flammable substances.

Warning Follow Petroleum Equipment Institute "Recommended Practices for Installation of Underground Liquid Storage Systems" (PEI/RP100). Failure to follow these practices could result in severe injury, death, serious property damage and/or environmental contamination.

Inspect the spill container assembly for damage before installation.

DO NOT disassemble the spill container subassembly. All the seals are factory tested to ensure the integrity of the containment space.

Make sure O-rings & seals are free of nicks, cuts, dirt, and debris before installation.

Make sure O-rings & seals are well lubricated with a silicone based lubricant.

Replacement Parts (continued)

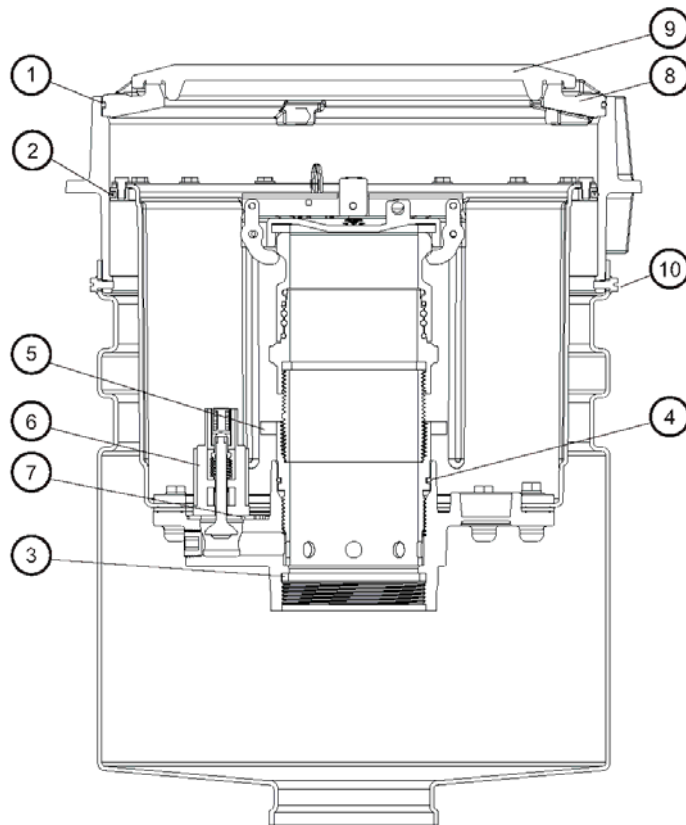

Figure 5: Defender Series™ Spill Container Spare Parts Location

Key	Description
1	Snow Plow Ring O-ring
2	Spill container Seal-ring
3	Tank Riser Gasket (NPSM model only)
4	DT Riser Clamp O-ring
5	DT Riser Clamp
6	Pull to Push Drain Valve
7	Drain valve Gasket
8	Snow Plow Ring Assembly
9	Cover, Cast Iron w/gasket (gray) Cover, FRC (Specify color)
10	Slotted, Hex-Head Self-Tapping Screws

4

Component and Subassembly Illustrations



Replacement Parts

Replacement Spill Container Subassemblies
Description

(Refer to Figure 1)

Cast Iron w/gasket (gray) NPSM

Preparation

New Site Application

1. Lay a string line or straight edge across the tank riser at finished grade height.
2. Cut the riser pipe so that the top edge will be 15.0" (381 mm) \pm 1.5" (38.1 mm) from finished grade. The actual height (elevated grade) of the bucket will be 1.0" (25.4 mm) above finished grade, to ensure proper water runoff (sloped dome).

Note: Cut the riser pipe square/perpendicular to ensure a flat sealing surface.

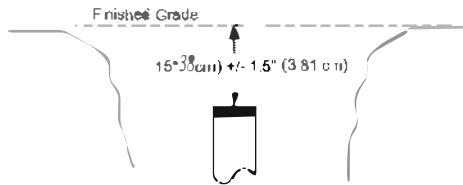

Figure 6: New Installation Riser Position

If it is intended to use a M/F 4x4 adapter, take into account the height of the adapter [1.75" (45 mm) installed].

- The riser pipe must be between 13.5" (343 mm) and 16.5" (419 mm) from the finished grade level.

Retrofit Application

1. Remove an appropriate size section of concrete around the existing spill container. The minimum recommended size is a 36" (914 mm) square around each spill container.
2. Remove the existing spill container.
3. Excavate a 24" (610 mm) diameter by 24" (610 mm) deep (measured from top of riser) around the riser pipe.

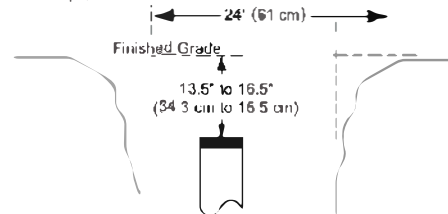

Figure 7: Retrofit Riser Position

4. Check the height of the riser pipe compared to finished grade level. Lay a straight edge across the excavated area and measure from grade to the top of the riser pipe. The riser pipe must be between 13.5" (343 mm) and 16.5" (419 mm).

5. Make sure the riser pipe was cut square/perpendicular to ensure a flat sealing surface.

If the pipe end is not cut square, an M/F 4x4 adapter may be used to provide an effective sealing surface as long as the length of riser pipe allows for it. The M/F 4x4 can also be used if the riser pipe is too short.

If the riser pipe is too long, it must be re-cut or replaced to obtain the appropriate length.

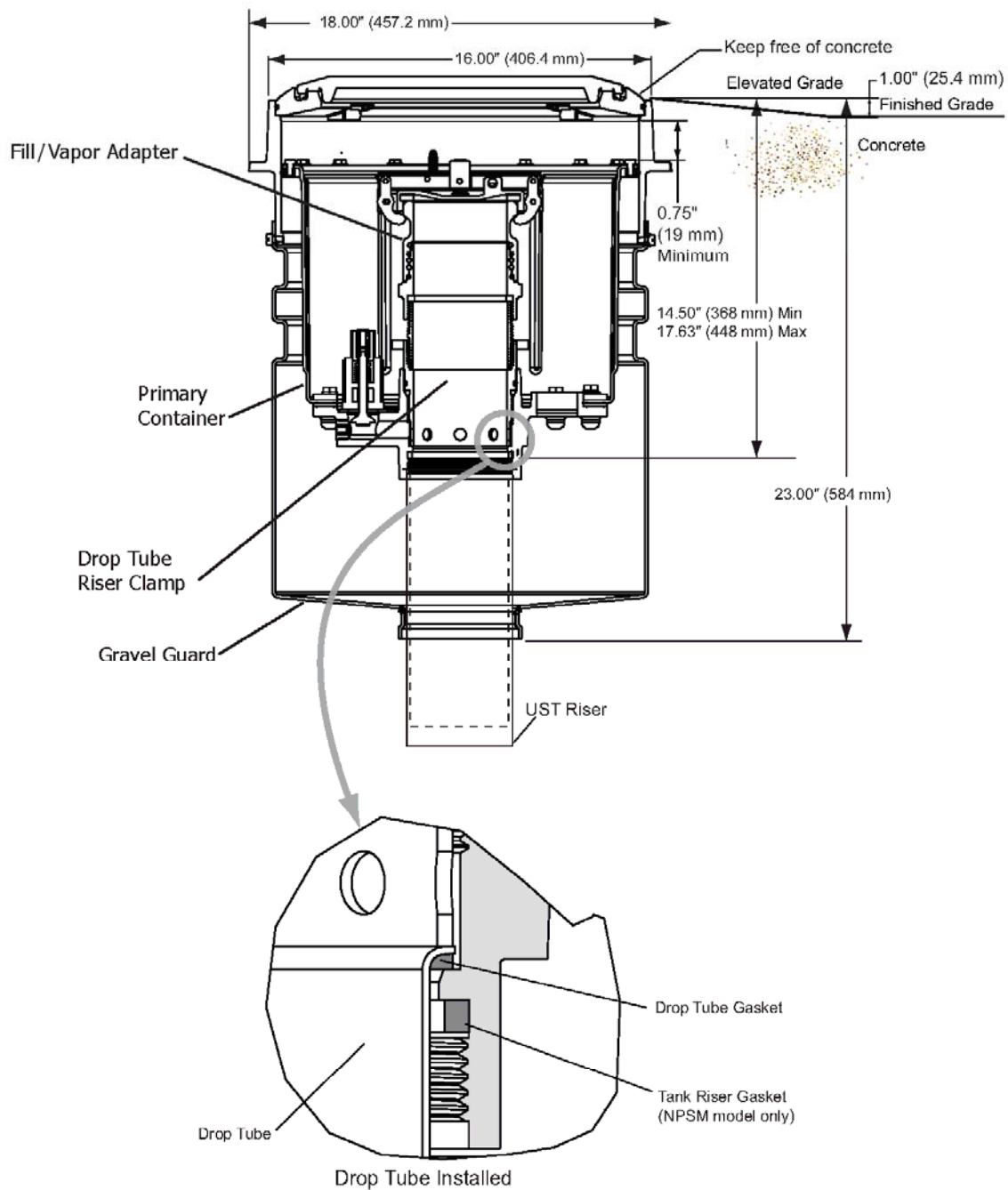

Figure 8: Defender Series™ Spill Container Overview

Installation

1. Remove the DT Riser Clamp Adapter from the Defender Series™ Spill container assembly
2. Use the round end of the T-7106 double ended tightening tool and the T-7001 T-Handle. The slot on the tool will engage with the lugs on the DT Riser Clamp Adapter.
3. Install the Spill Bucket onto the Tank Riser
 - a. If using NPSM (straight threads) buckets, apply grease or anti-sieze compound onto the threads. Torque buckets to 75-100 Ft Lbs using the T-7106 tool.
 - b. If using NPT (taper thread) buckets, apply a non-hardening pipe thread sealant to the tank riser threads. Tighten bucket using the T-7106 tool.

Note: If local codes or regulations require a tightness test using a leak detecting solution at the tank riser/spill bucket joint:

- a. Make sure the snowplow ring is installed in the concrete ring before proceeding.
 - b. Remove the (4) slotted hex-head self-tapping screws from the gravel guard.
 - c. Slide the gravel guard down to access the joint between the tank riser and the spill bucket.
 - d. Perform a tightness test.
 - e. Reinstall the gravel guard and attach it with three (3) self-tapping screws.
3. Adjust the height of the top edge to the ELEVATED grade, which should be approximately 1" (25.4 mm) above finished grade level (1" (25.4 mm) of rain runoff dome).
 4. Adjust the height of the top edge to three ELEVATED grade, which should be approximately 1" (25.4 mm) above finished grade level (1" (25.4 mm) of rain runoff dome).
 5. If needed, support the gravel guard/concrete ring with backfill.
 - If backfill is not available, temporarily support the concrete ring with 2x4s underneath the outer edge.
 6. Install the drop tube through the spill container to allow the gasket to seat on the sealing ledge.
 - Retrofit Installation Only – Double check to see that the existing drop tube is cut to the appropriate length.
 7. If the unit was ordered with the riser, cap, and fill/vapor adapter – they should all be pre-assembled to the DT Riser Clamp Adapter – SKIP TO STEP 10
 8. Assemble the DT Riser Clamp Adapter to the pipe nipple and fill/vapor adapter
 - Use only the flats on the top of the DT Riser Clamp Adapter for tightening.
 - Cut & thread the DT Riser Pipe. The overall length of the DT Riser Clamp Adapter assembly including the adapter and dust cap should be no more than 12.5" (317.5 mm).

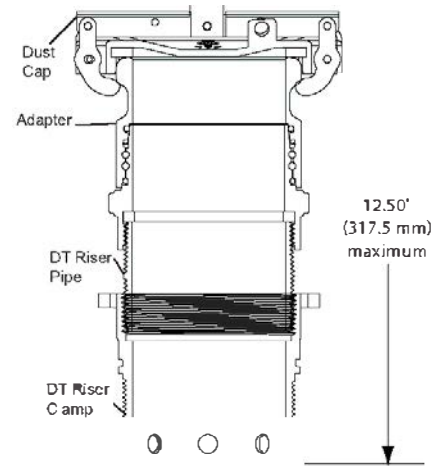

Figure 9: Drop Tube (DT) Riser Clamp Assembly Dimensions

- Use a thread sealant between the pipe nipple & the DT Riser Clamp.
 - Torque to the manufacturer's recommended value using the correct tools.
9. Install the DT Riser Clamp Adapter into the spill container using the round end of the T 7106 double ended tightening tool and T-7001 T-Handle. Torque to 75-100 ft-lbs (101.7 N-m - 135.6 N-m). The slots on the tool will engage with the lugs on the DT riser clamp adapter.
 10. Install fill/vapor dust cap.
- Note: Verify that when the dust cap is installed, it does not interfere with the underside of the spill container lid.
11. Double-check & verify the gravel guard/concrete ring assembly is still at ELEVATED grade height, adjust if necessary.
 12. Perform the integrity testing AFTER BACKFILL but BEFORE CONCRETE.
 - See Integrity Testing on Page 8
 13. Install spill container cover/lid.
 14. Pour concrete around the Defender Series™ spill container, making sure to dome the concrete at least 1" (2.54cm) to allow for adequate runoff. The sloping of the concrete should begin at the outer edge of the concrete ring tabs (Figure 13). Keep the snow plow ring and cover clean and free of any concrete splatter (the snow plow ring must be able to be removed if service is needed).

- 15. If equipped with a drain, adjust the position of the lower key ring on the chain so that the drain is held open when clipped up on the ledge of the snow plow ring.
- 16. Attach the upper most key ring to the fill/vapor dust cap.



Figure 10: Drain Chain and Clip Shown installed, holding drain open

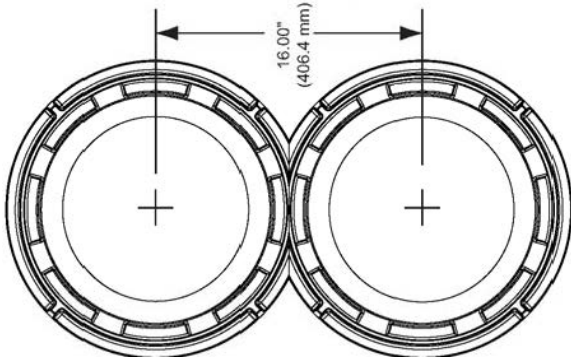

Figure 11: 16" On-Center Mounting (Top View)

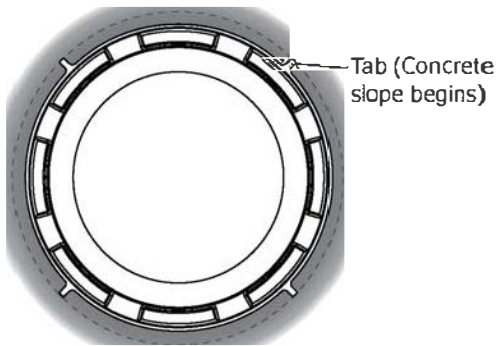

Figure 12: Concrete Placement

Integrity Testing

All Defender spill buckets are integrity tested at the factory. We recommend that the containment integrity be re-confirmed. Always test per local codes. If local codes do not specify a procedure, or refers to the manufacturer's testing, Perform Hydrostatic Testing Procedure as below.

Hydrostatic Testing Procedure

- 1. Fill the spill bucket with water until the level is just below the upper lip of the snow plow ring.
- 2. After 1 hour, if there is no detectable drop in water level, the spill bucket has passed the test.

Integrity Testing recommendations

Test upon installation and thereafter per local codes. Otherwise, test every 3 years

Monthly Recommended Maintenance & Inspection Procedures

- 1. Clean any sand, gravel, or dirt from the snow plow ring. Buildup of material will prevent the manhole lid from sitting flat and diverting rain water. In addition to water infiltration, this can lead to premature lid failures and tripping hazards.
- 2. Inspect the cover gasket and replace it if necessary.
- 3. Inspect the spill container for the presence of liquid. If any is present, identify the material (water or fuel) and dispose of it using your preferred acceptable method (pump it out or drain it into the tank).
- 4. Inspect the primary spill container and the drain valve screen for any foreign material collecting in the bottom of the tank. Remove any large objects (leaves, rags, etc.) and wipe the bottom of the tank with a disposable rag.
- 5. Inspect the entire spill container assembly and components for any obvious damage. Verify that all components are functioning properly.
- 6. Record Inspection results per local codes.

Spill Container Subassembly Replacement

Removal

1. Remove cover.
2. Remove the snow plow ring.
 - Unthread the snow plow ring bolts using a 1/2" (13 mm) socket or nut driver, until the heads of the bolts extend past the I.D. approximately 1/2" (13 mm).
 - Pull up on the snow plow ring firmly to break the seal between the O-ring and the concrete ring.
3. Remove the dust cap.
4. Using the round end of the T 7106 double ended installation tool and T 7001 T Handle remove the DT riser clamp adapter.
5. Remove the drop tube assembly.
6. Using the square end of the T 7106 double ended installation tool and the T-7001 T-Handle, unthread the spill container assembly.
7. Pull up firmly and evenly on the spill container to remove the spill container from the concrete ring/gravel guard.

Installation

1. Clean the I.D. of the concrete ring (sealing surface) thoroughly and re-lubricate with a silicone based O-ring lubricant or spray.
2. Apply a NON-HARDENING thread sealant to the tank riser.
3. Lubricate the seal on the outside of the spill container with a silicone based O-ring lubricant or spray.
4. Evenly push down on the spill container subassembly to seat the seal-ring, & slide it down to where the bucket meets the tank riser.
5. Thread on the spill container subassembly to the tank riser using square end of the T-7106 double-ended installation tool and The T 7001 T Handle. Torque to 125-150 ft-lbs (169.5-203.4 N-m) using a 1/2" (13 mm) drive torque wrench.
6. Re-install the drop tube assembly.
 - Check the drop tube gasket and replace if necessary.
7. Re-install the DT Riser Clamp Adapter into the spill container using the round end of the T-7106 double ended tightening tool and T-7001 T-Handle. The slots on the tool will engage with the lugs on the DT riser clamp adapter. Torque to 75-100 ft-lbs (102-136 N-m).
8. Re-install the snow plow ring into the concrete ring.
 - Re-lubricate the O-ring.
 - Align the (4) bolts to the ribs on the concrete ring.

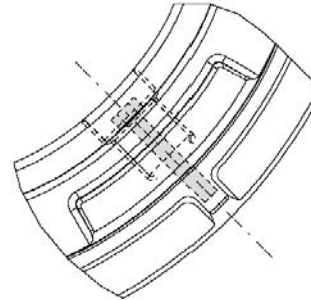

Figure 13: Snow Plow Ring Bolt Location

- Push down on the snow plow ring to seat the O ring.
 - Using the 1/2" (13 mm) socket or nut driver, tighten the (4) bolts into the concrete ring (hand tight).
9. Re-install the dust cap.
 10. Re-install the cover.

Page intentionally blank



3760 Marsh Road • Madison, WI 53718, U.S.A.
Tel: +1 608 838 8786 • Fax: +1 608 838 6433
Tel: USA & Canada 1 800 225 9787 • Tel: México 001 800 738 7610

Franklin Fueling Systems GmbH
Rudolf-Diesel-Strasse 20 • 54516 Wittlich, GERMANY
Tel: +49-6571-105-380 • Fax: +49-6571-105-510

Figure M-2: Defender Series Spill Container Double Wall Configuration Installation, Operation, and Maintenance Instructions



INSTALLATION, OPERATION, & MAINTENANCE



Franklin Fueling Systems • 3760 Marsh Rd. • Madison, WI 53718 USA
Tel: +1 608 838 8786 • 800 225 9787 • Fax: +1 608 838 6433 • www.franklinfueling.com

Component and Subassembly Illustrations



Figure 1: Double Wall Spill Container Subassembly

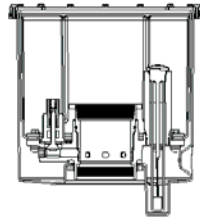

Figure 2: Double Wall Spill Container with Sensor Subassembly

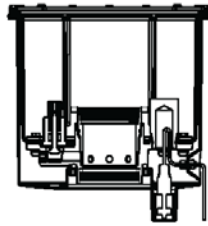

Figure 3: Gravel Guard and Concrete Ring

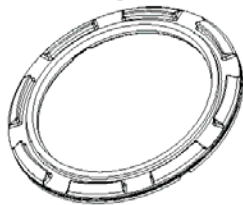

Figure 4: Snow Plow Ring

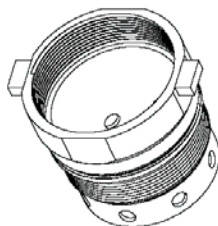

Figure 5: Drop Tube (DT) Riser Clamp Adapter

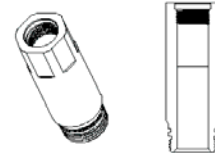

Figure 6: Inspection Port Pipe for P Monitor (Optional)

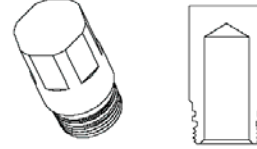
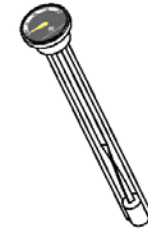

Figure 7: Inspection Port Pipe for Sensor (Optional)



Figure 8: I² (Interstitial Integrity) Monitor (Optional)



Replacement Parts

Replacement Spill Container Subassemblies

Description
(Refer to Figure 1)
Double Wall, with I2 Monitor, with Drain, NPSM
Double Wall, with I2 Monitor, no Drain, NPSM
Double Wall, with I2 Monitor, with Drain, NPT
Double Wall, with I2 Monitor, no Drain, NPT
(Refer to Figure 2)
Double Wall, with Sensor, with Drain, NPSM
Double Wall, with Sensor, no Drain, NPSM
Double Wall, with Sensor, with Drain, NPT
Double Wall, with Sensor, no Drain, NPT

Contents

Component and Subassembly Illustrations3
 Replacement Parts..... 3-4
 Preparation.....5
 New Site/Retrofit Site/Electronic Sensor.....5

Cautions / Warnings



Follow all federal, state and local laws governing the installation of this product and its associated systems. When no other regulations apply, follow NFPA codes 30, 30A and 70 from the National Fire Protection Association.

Replacement Parts (continued)

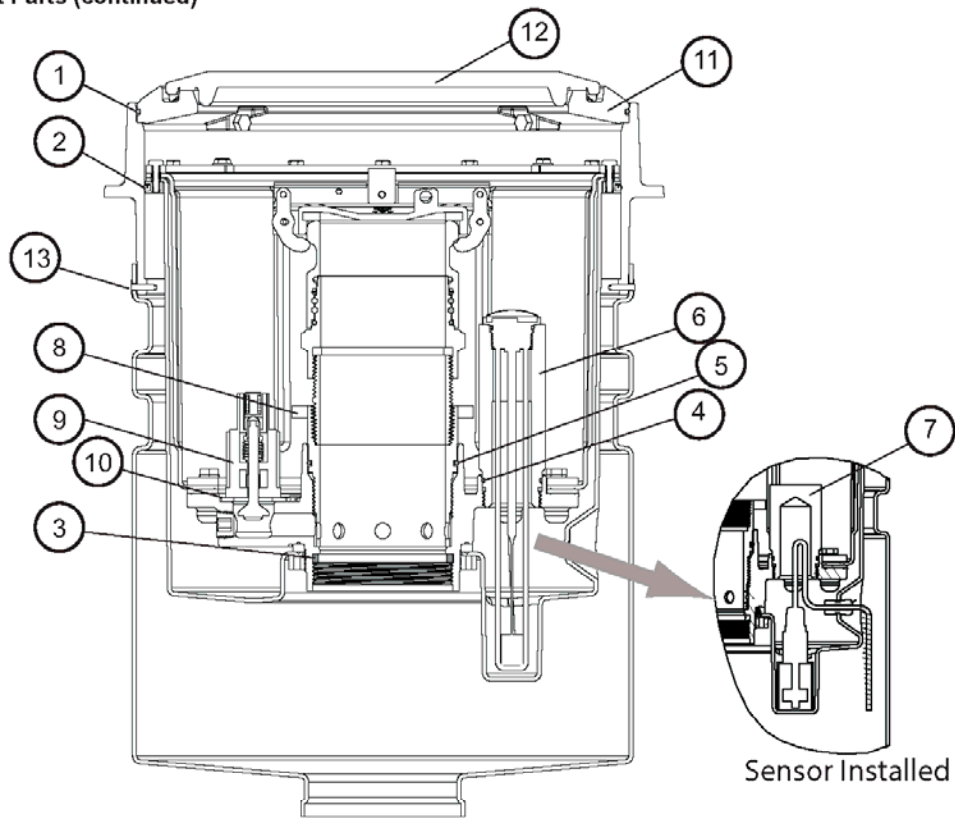

Figure 9: Defender Series™ Spill Container Spare Parts Location

Key	Description
1	Snow Plow Ring O-ring
2	Spill container Seal-ring
3	Tank Riser Gasket (NSPM models Only)
4	Inspection Port Pipe O-ring
5	DT Riser Clamp O-ring
6	I² Monitor Assembly
7	Inspection Port (Sensor)
8	DT Riser Clamp
9	Pull to Push Drain Valve
10	Drain valve Gasket
11	Snow Plow Ring Assembly
12	Cover, Cast Iron w/gasket (gray)
	Cover, FRC (Specify color)
13	Slotted hex head self-tapping screw

Preparation

New Site Application

1. Lay a string line or straight edge across the tank edge, at finished grade height.
2. Cut the riser pipe so that the top edge will be 15 0" (381 mm) +/- 1.5" (38.1 mm) from finished grade. The actual height (elevated grade) of the bucket will be 1 0' (25.4mm) above finished grade, to ensure proper water runoff (sloped dome).

Note: Cut the riser pipe square/perpendicular to ensure a flat sealing surface.

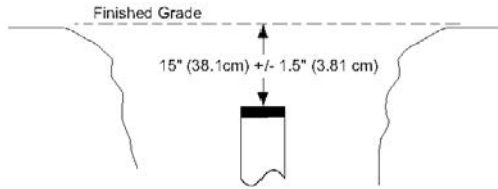

Figure 10: New Installation Riser Position

- If it is intended to use a M/F 4x4 adapter take into account the height of the adapter [1.75" (45 mm) installed].
- The riser pipe must be between 13.5" (343 mm) and 16.5" (419 mm) from the finished grade level.

Retrofit Application

1. Remove an appropriate size section of concrete around the existing spill container. The minimum recommended size is a 36" (914 mm) square around each spill container.
2. Remove the existing spill container.
3. Excavate a 24" (610 mm) diameter by 24" (610 mm) deep (measured from top of riser) around the riser pipe.



Figure 11: Retrofit Riser Position

4. Check the height of the riser pipe compared to finished grade level. Lay a straight edge across the excavated area and measure from grade to the top of the riser pipe. The riser pipe must be between 13.5" (343 mm) and 16.5" (419 mm).
5. Make sure the riser pipe was cut square/perpendicular to ensure a flat sealing surface.
 - If the pipe end is not cut square, an M/F 4x4 adapter may be used to provide an effective sealing surface as long as the length of riser pipe allows for it. The M/F 4x4 can also be used if the riser pipe is too short.
 - If the riser pipe is too long, it must be re cut or replaced to obtain the appropriate length.

Electronic Sensor Preparation

1. Separate the spill container subassembly from the gravel guard/concrete ring subassembly.
 - a. Remove the snow plow ring.
 - Unthread the snow plow ring bolts using a 1/2" socket or nutdriver, until the heads of the bolts extend past the I.D. approximately 1/2" (13 mm).
 - Pull up on the snow plow ring firmly to break the seal between the O-ring and the concrete ring.
 - b. Remove the spill container subassembly.
 - Turn the unit upside-down so the concrete ring is on the ground.
 - Firmly push on the spill container subassembly to unseat the seal, and the bucket will come out of the concrete ring.
 2. Locate the gravel guard/concrete ring subassembly.
 3. Drill the appropriate sized hole for the conduit penetration supplied by the electrical contractor. It can be drilled in either the side or the bottom of the gravel guard. If drilled in the side, make sure to keep it as low as possible.
- Caution:** Make sure the spill container is not installed in the gravel guard/concrete ring as you risk puncturing the containment.
4. Install the conduit penetration fitting into the gravel guard.
 5. Measure at least 10 feet (3 meters) of cable from the end spill container cord grip & mark it with a marker or piece of tape. This will be the minimum amount of cable to be left loose inside the gravel guard to allow for installation & removal of the spill container. The rest of the length is available for connection into another sump or junction box.

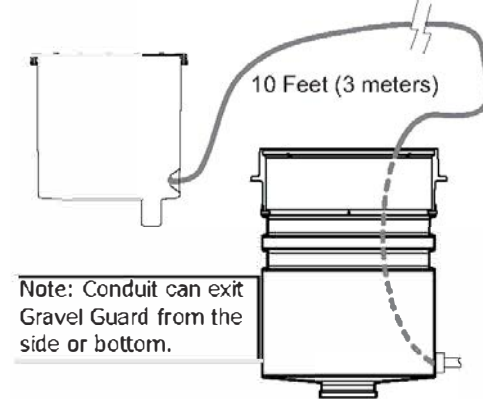

Figure 12: Cable Allowance

Caution: Do not loosen the cord grip on the spill container because it will compromise the seal integrity of the factory tested interstitial space.

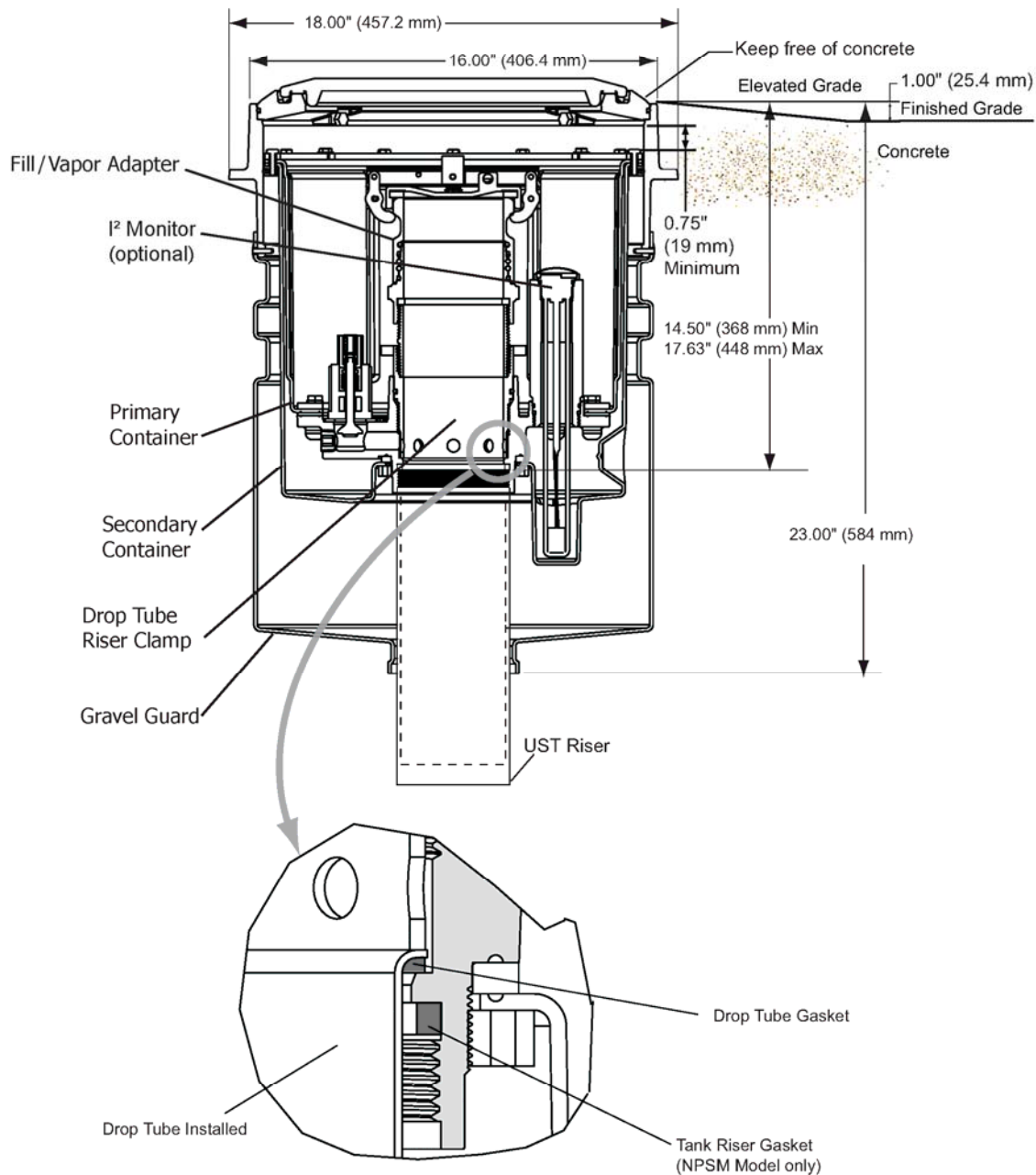

Figure 13: Defender Series™ Spill Container Overview

Installation

Electronic Sensor Model Only

- Slide the gravel guard/concrete ring subassembly over the tank riser.
- Locate the spill container subassembly and remove the DT (Drop Tube) Riser Clamp Adapter.
 - Use the round end of the T-7106 double ended tightening tool and the T-7001 T-Handle. The slots on the tool will engage with the lugs on three DT Riser Clamp Adapter.
- Feed the sensor cable through the conduit penetration as far as the 10 foot (3 meter) marker previously made in the preparation section.
- Wrap excess cable **counterclockwise** around the riser at least 7 times. This will help prevent the cable from binding when the spill container is threaded onto the riser.
- Install the spill bucket onto the tank riser.
 - If using NPSM (straight threads) buckets, apply grease or anti-sieze compound onto the threads. Torque buckets to 75-100 Ft Lb using the T-7106 tool.
 - If using NPT (taper thread) buckets, apply a non hardening pipe thread sealant to the tank riser threads. Tighten bucket using the T 7106 tool.

Note: If local codes or regulations require a tightness test using a leak detecting solution at the tank riser/spill bucket joint, do so now before raising the gravel guard and concrete ring subassembly

- Raise the gravel guard & concrete ring subassembly up around the spill container & pull firmly to seat the concrete ring ID onto the seal-ring.
 - Make sure the ID of the concrete ring is free of dirt and debris. Make sure the seal-ring is free of nicks, cuts, dirt, and debris.
 - Make sure the seal-ring is lubricated with a silicone based lubricant.
- Install the snow plow ring into the concrete ring.
 - Make sure the O-ring is free of nicks, cuts, dirt, and debris. Make sure the O-ring is lubricated with a silicone based lubricant.
 - Align the (4) bolts to the ribs on the concrete ring.

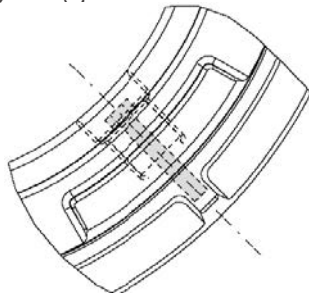

Figure 14: Snow Plow Ring Bolt Location

- Push down on the snow plow ring to seat the O-ring.
 - Using the 1/2" socket or nut driver, tighten these (4) bolts into the concrete ring (hand tight).
- Adjust the height of the top edge to the ELEVATED grade, which should be approximately 1" (25.4mm) above finished grade level (1" (25.4mm) of rain runoff dome).
 - Install the conduit into the conduit penetration & feed the sensor wire through the conduit.

Non-Sensor Models

- Remove the DT Riser Clamp Adapter from three Defender Series™ Spill container assembly.
- Use the round end of the T-7106 double ended tightening tool and the T-7001 T-Handle. The slot on the tool will engage with the lugs on the DT Riser Clamp Adapter.
- Apply a NON-HARDENING thread sealant to three tank riser.
- Thread on the Defender Series™ Spill container assembly to the tank riser and tighten using square end of the T-7106 double-ended installation tool and the T-7001 T-Handle. Torque to 125-150 ft-lbs (170-203 N-m) using a 1/2" drive torque wrench.

Note: If local codes or regulations require a tightness test using a leak detecting solution at the tank riser/spill bucket joint:

- Make sure the snowplow ring is installed in the concrete ring before proceeding.
 - Remove the (4) slotted hex-head self-tapping screws from the gravel guard.
 - Slide the gravel guard down to access the joint between the tank riser and the spill bucket.
 - Perform a tightness test.
 - Reinstall the gravel guard and attach it with the (4) self-tapping screws.
- Adjust the height of the top edge to the ELEVATED grade, which should be approximately 1" (25.4mm) above finished grade level (1" (25.4mm) of rain runoff dome).

All Models

- If needed, support the gravel guard/concrete ring with backfill.
 - If backfill is not available, temporarily support three concrete ring with 2x4s underneath the outer edge.
- Install the drop tube through the spill container to allow the gasket to seat on the sealing ledge.
 - Retrofit Installation Only* – Double check to see that the existing drop tube is cut to the appropriate length.
- If the unit was ordered with the riser, cap, and fill/vapor adapter – they should all be pre-assembled to the DT Riser Clamp Adapter – SKIP TO STEP 7.

4. Assemble the DT Riser Clamp Adapter to the pipe nipple and fill/vapor adapter
 - Use only the flats on the top of the DT Riser Clamp Adapter for tightening.
 Cut & thread the DT Riser Pipe. The overall length of the DT Riser Clamp Adapter assembly including the adapter and dust cap should be no more than 12.5" (317.5 mm).

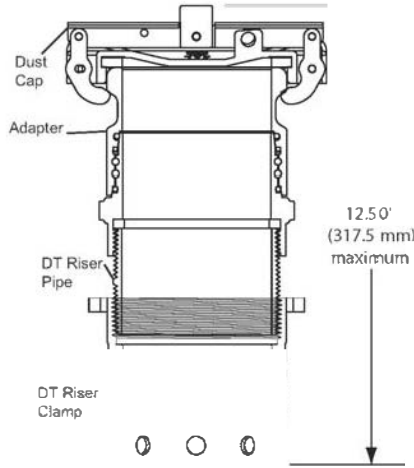

Figure 15: Drop Tube (DT) Riser Clamp Assembly Dimensions

Use a thread sealant between the pipe nipple & the DT Riser Clamp.

- Torque to the manufacturer's recommended value using the correct tools.
5. Install the DT Riser Clamp Adapter into the spill container using the round end of the T 7106 double ended tightening tool and T-7001 T-Handle. Torque to 75-100 ft-lbs (101.7 N-m - 135.6 N-m). The slots on the tool will engage with the lugs on the DT riser clamp adapter.
 6. Install fill/vapor dust cap.
- Note:** Verify that when the dust cap is installed, it does not interfere with the underside of the spill container lid.
7. Double-check & verify the gravel guard/concrete ring assembly is still at ELEVATED grade height, adjust if necessary.
 8. Perform the integrity testing AFTER BACKFILL but BEFORE CONCRETE.
 - See Integrity Testing on Page 9
 9. Install spill container cover/lid.
 10. Pour concrete around the Defender Series™ spill container, making sure to dome the concrete at least 1" (2.54 cm) to allow for adequate runoff. The sloping of the concrete should begin at the outer edge of the concrete ring tabs (Figure 18). Keep the snow plow ring and cover clean and free of any concrete splatter (the snow plow ring must be able to be removed if service is needed).

11. If equipped with a drain, adjust the position of the lower key ring on the chain so that the drain is held open when clipped up on the ledge of the snow plow ring.
12. Attach the upper most key ring to the fill/vapor dust cap.

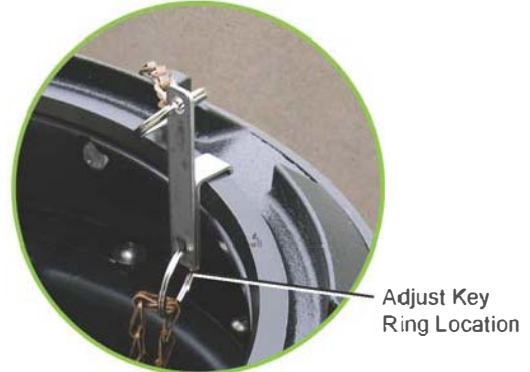

Figure 16: Drain Chain and Clip Shown installed, holding drain open

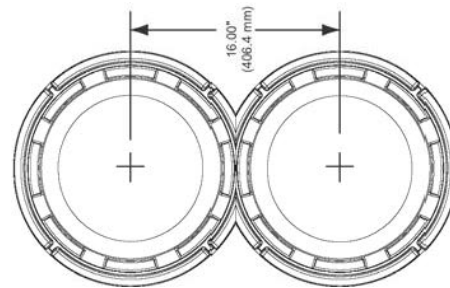

Figure 17: 16" On-Center Mounting (Top View)

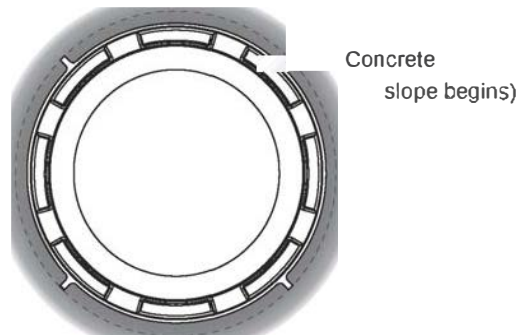

Figure 18: Concrete Placement

Integrity Testing

All Defender™ spill buckets are integrity tested at the factory. We recommend that the containment integrity be reconfirmed. Always test per local codes. If local codes do not specify a procedure, or refers to the manufacturer's testing, use the testing as below.

Double Wall: Perform Hydrostatic Testing Procedure and the Vacuum Interstitial Testing Procedure.

Hydrostatic Testing Procedure

1. Fill the spill bucket with water until the level is just below the upper lip of the snow piling ring.
2. After 1 hour, if there is no detectable drop in water level, the spill bucket has passed the test.

Vacuum Interstitial Testing Procedure

1. Remove the Inspection Port Pipe from the spill container.
2. Install the T-7107 DW Vacuum Test Kit into the inspection port (hand tight).
 - Make sure the O ring is properly lubricated, clean of dirt and debris, and the I.D. sealing surface of the inspection port is clean of dirt and debris.
 - If the unit includes a sensor, it does not need to be removed.

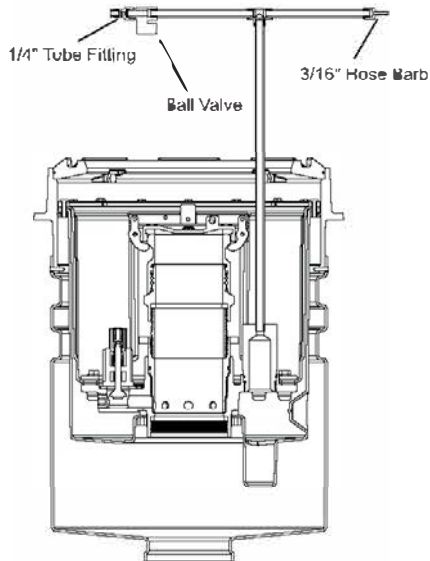

Figure 19: Tool T-7001 Installed

3. Connect the vacuum source to the 1/4" tube fitting (Push-Lok/Push to connect).
4. Connect the manometer to the 3/16" hose barb.
5. Close the ball valve.
6. Apply vacuum source (using a pump or generator) and SLOWLY open the ball valve until the manometer reads 30 inches of water column (WC) (7.472 kPa), then close the ball valve.
7. Wait approximately 1 minute to allow the interstitial space to stabilize.
8. If needed, re apply the vacuum source to obtain 30" WC (7.472 kPa).
9. Allow spill container to rest undisturbed for 5 minutes while under vacuum.
10. Check the manometer reading after 5 minutes. If it reads above 26" WC (6.476 kPa), the interstitial space has passed the test.
11. If the manometer reads less than 26" WC (6.476 kPa), check all the connections and repeat the test. Otherwise contact Franklin Fueling Systems Technical Service.

Integrity Testing Recommendations

Test upon installation and thereafter per local codes. Otherwise, test every 3 years.

Recommended Maintenance & Inspection Procedures

Monthly

1. Clean any sand, gravel, or dirt from the snow plow ring. Buildup of material will prevent the manhole lid from sitting flat and diverting rain water. In addition to water infiltration, this can lead to premature lid failures and tripping hazards.
2. Inspect the cover gasket and replace it if necessary.
3. Inspect the spill container for the presence of liquid. If any is present, identify the material (water or fuel) and dispose of it using your preferred acceptable method (pump it out or drain it into the tank)
4. Inspect the primary spill container and the drain valve screen for any foreign material collecting in the bottom of the tank. Remove any large objects (leaves, rags, etc.) and wipe the bottom of the tank with a disposable rag.
5. Inspect the entire spill container for obvious damage. Verify that all components are functioning properly.
6. Inspect the interstitial space for the presence of liquid.

If it is installed with the I² monitor, check the yellow indicator position. If the yellow indicator is positioned below the white area on the gauge face, liquid is not detected.

If it is installed with the TSP-ULS electronic sensor, check the tank gauge equipment located inside the station. Confirm the sensor status is normal and does not show an alarm condition.

If liquid is detected by either monitoring method, identify and properly dispose of the liquid. Confirm the status of the interstitial space by performing the Vacuum Interstitial Integrity Procedure.

Yearly

1. Inspect the interstitial monitoring equipment.
 - If it is installed with the I² monitor, test the operation of the float/Indicator mechanism. Remove the I² monitor/port pipe assembly by unscrewing it from the tank adapter. Manually move the float up and down and verify that the float moves freely and the indicator arrow rotates.
 - If it is installed with the TSP-ULS electronic sensor, check to see that it is functioning properly. Remove the inspection port pipe from the tank adapter to gain access to the sensor. Remove the sensor from the interstitial space and turn it upside down to raise the float. Verify with the tank gauge in the station that a sensor alarm occurred. If it did, the sensor is operating properly. Reinstall the sensor and the inspection port pipe.
2. Record inspection results per local codes.

Spill Container Subassembly Replacement Removal

1. Remove cover.
2. Remove the snow plow ring.
 - Unthread the snow plow ring bolts using a 1/2" (13 mm) socket or nut-driver, until the heads of the bolts extend past the I.D. approximately 1/2" (13mm).
 - Pull up on the snow plow ring firmly to break the seal between the O-ring and the concrete ring.
3. Remove the dust cap.
4. Using the round end of the T-7106 double-ended installation tool and T-7001 T-Handle, remove the DT riser clamp adapter.
5. Remove the drop tube assembly.
6. Using the square end of the T-7106 double ended installation tool and the T-7001 T-Handle, unthread the spill container assembly.
7. Pull up firmly and evenly on the spill container to remove the spill container from the concrete ring & gravel guard.

Installation

1. Clean the I.D. of the concrete ring (sealing surface) thoroughly and re-lubricate with a silicone based O-ring lubricant or spray.
2. Apply a NON-HARDENING thread sealant to the tank riser.
3. Lubricate the seal on the outside of the spill container with a silicone based O-ring lubricant or spray.
4. Evenly push down on the spill container subassembly to seat the seal ring, & slide it down to where the bucket meets the tank riser.
5. Thread on the spill container subassembly to the tank riser using square end of the T-7106 double ended installation tool and The T-7001 T-Handle. Torque to 125-150 ft-lbs (169.5 - 203.4 N-m) using a 1/2" (13mm) drive torque wrench.
6. Re install the drop tube assembly.
 - Check the drop tube gasket and replace if necessary.
7. Re install the DT Riser Clamp Adapter into the spill container using the round end of the T-7106 double ended tightening tool and T-7001 T-Handle. The slots on the tool will engage with the lugs on the DT riser clamp adapter. Torque to 75-100 ft lbs (102-136 N m).
8. Re install the snow plow ring into the concrete ring.
 - Replace and lubricate the O-ring.
 - Align the (4) bolts to the ribs on the concrete ring.

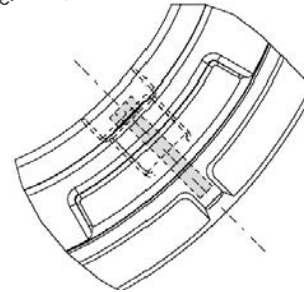

Push down on the snow plow ring to seat the O-ring.

Using the 1/2" (13 mm) socket or nut driver, tighten the (4) bolts into the concrete ring (hand tight).

9. Re install the dust cap.
10. Re-install the cover.



3760 Marsh Road • Madison, WI 53716, U.S.A.
Tel: +1 608 838 8786 • Fax: +1 608 838 6433
Tel: USA & Canada 1 800 225 9787 • Tel: México 001 800 738 7510

Franklin Fueling Systems GmbH
Rudolf-Diesel-Strasse 20 • 54516 Wittlich, GERMANY
Tel: +49-6571-105-380 • Fax: +49-6571-105-510

**Figure M-3: Defender Series Spill Container Single Wall Fiberglass Configuration
Installation, Operation, and Maintenance Instructions**



DEFENDER SERIES™

5 Gallon, Single Walled, Field Replaceable Spill Container

Fiberglass Model 705-54X Series

INSTALLATION, OPERATION, & MAINTENANCE

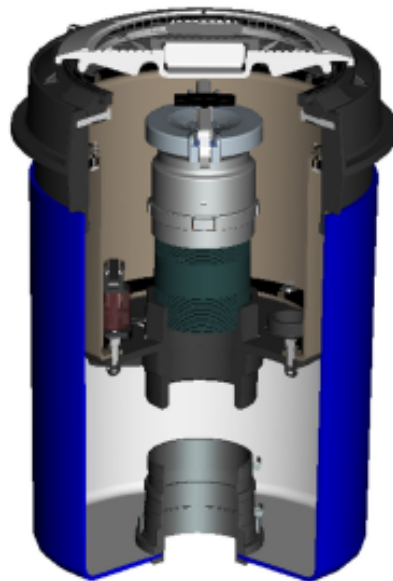

Franklin Fueling Systems • 3760 Marsh Rd. • Madison, WI 53718 USA

Tel: +1 608 838 8786 • 800 225 9787 • Fax: +1 608 838 6433 • www.franklinfueling.com

Contents

Component and Subassembly Illustrations 3
 Replacement Parts 3-4
 Preparation 5
 New Site/Retrofit Site See
 Installation Overview 5
 Installation 6
 Integrity Testing 7
 Spill Container Subassembly Replacement 8

Tools Required

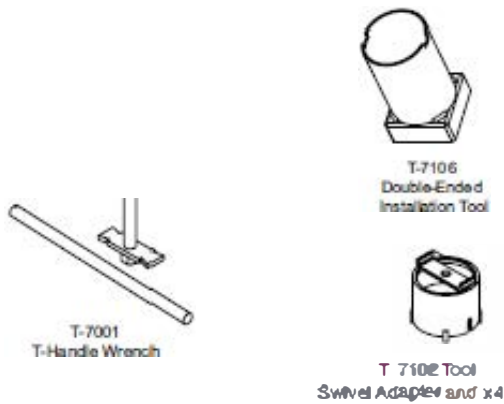

- 1/2" Socket or Nut Driver
- 1/2" Drive Torque Wrench
- Silicone based O-ring lubricant or silicone spray
- NON HARDENING thread sealant approved for gasoline service

Torque Specifications

Location	Ft lbs (N-m)
Spill Container to UST Riser Pipe	125-150 (170-203)
Swivel Adapter to Pipe Nipple	75-100 (102-136)

Cautions / Warnings

Warning Follow all federal, state and local laws governing the installation of this product and its associated systems. When no other regulations apply follow NFPA codes 30e80A and 70 from the National Fire Protection Association. Failure to follow these codes could result in severe injury, death, serious property damage and/or environmental contamination.

Warning Always secure the work area from moving vehicles. To help eliminate unsafe conditions, secure the area by using a service truck to block access to the work environment or by using any other reasonable means available to ensure the safety of service personnel. The Defender Series Spill Containment is used with tanks containing gasoline or other flammable substances.

Warning Follow Petroleum Equipment Institute 'Recommended Practices for Installation of Underground Liquid Storage Systems' (PEI/RP100). Failure to follow these practices could result in severe injury, death, serious property damage and/or environmental contamination.

Inspect the spill container assembly for damage before installation.

DO NOT disassemble the spill container subassembly. All the seals are factory tested to ensure the integrity of the containment space.

Make sure O-rings & seals are free of nicks, cuts, dirt, and debris before installation.

Make sure O-rings & seals are well lubricated with a silicone based lubricant.

Component and Subassembly Illustrations



*Figure 1: Single Wall Spill Container Subassembly
705541001/02*



Figure 3: Snow Plow Ring



Figure 2: Gravel Guard and Concrete Ring



Figure 4: Entry Boot

Replacement Parts

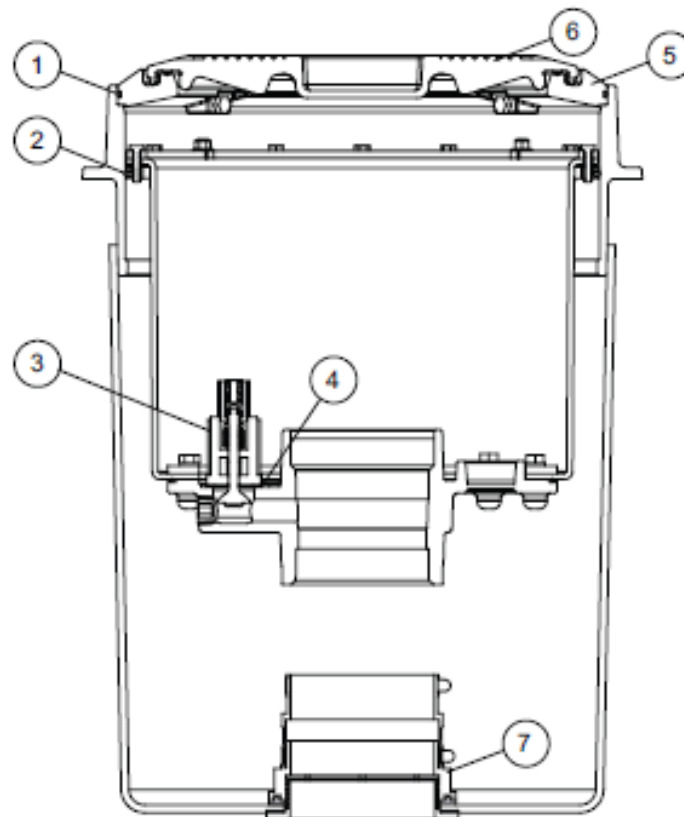

Figure 5: Defender Series™ (Fiberglass) Spill Container Spare Parts Location

Key	Description	Part Number
1	Snow Plow Ring O-ring	602009006
2	Spill container Seal-ring	70550301
3	Pull to Push Drain Valve	70533701
4	Drain valve Gasket	70522601
5	Snow Plow Ring Assembly	70553001
6	Cover, Cast Iron w/gasket (gray)	70544001
	Cover, FRC (Specify color)	705420XX 705423XX
7	Entry Boot	602046001
*	Drain Chain and Clip	70553101

* Not shown

Preparation

New Spill Container

1. Lay a string line or straight edge across the tank at finished grade height.
2. Cut the riser pipe so that the top edge will be 15" (381 mm) +/- 1.5" (38.1 mm) from finished grade. The actual height (excavated grade) of the bucket will be 1'0" (264 mm) above finished grade, to ensure proper water runoff (sloped dome).

Note: Cut the riser pipe square/perpendicular to ensure a flat sealing surface.

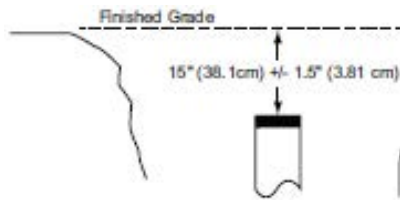

Figure 6: New Installation Riser Position

The riser pipe must be between 13'5" (343 mm) and 16'5" (419 mm) from the finished grade.

Retrofit Application

1. Remove an appropriate size section of concrete around the existing spill container. The minimum recommended size is a 36" (914 mm) square around each spill container.
2. Remove the existing spill container.
3. Excavate a 24" (610 mm) diameter by 24" (610 mm) deep (measured from top of riser) around the riser pipe.

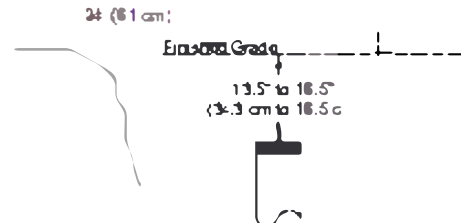

Figure 7: Retrofit Riser Position

4. Check the height of the riser pipe compared to finished grade. Lay a straight edge across the excavated area and measure from grade to the top of the riser pipe. The riser pipe must be a between 13'5" (343 mm) and 16'5" (419 mm).
5. If the riser pipe is too long it must be re-cut or replaced to obtain the appropriate height.

Installation Overview

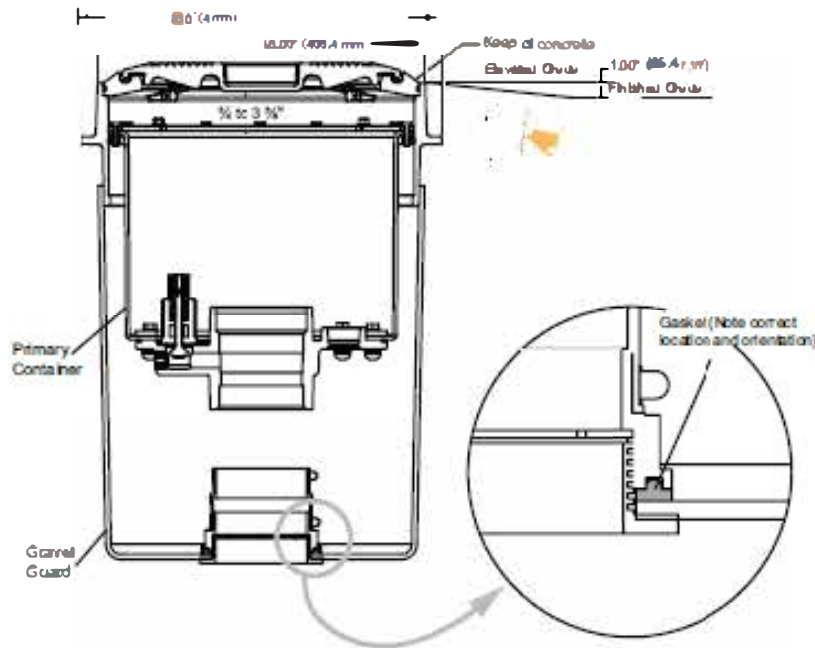

Figure 8: Defender Series Spill Container Overview

Installation

1. Remove the snow plow ring from the spill bucket assembly
 - a. Untighten the snow plow ring bolts using a ½" socket or nut driver until the heads of the bolts extend past the ID approximately ½"
 - b. Pull up on the snow plow ring firmly to break the seal between the ring and the concrete ring
2. Remove the spill container from the gravequard
3. Install the entry boot at the gravel guard. Make sure the gasket is on the inside of the gravequard (against the white geocoat) and NOT on the outside against the fiberglass
4. Loosen the band clamps around the entry boot cuff
5. Slide the concrete ring/gravequard over the tank riser
6. Adjust the height of the top edge to the ELEVATED grade which should be approximately 1" (25.4 mm) above finished grade level (1" (25.4 mm) of runoff dome)
7. If needed, support the gravequard/concrete ring with backfill.
 - If backfill is not available temporarily support the concrete ring with 2x4s underneath the outer edge
8. Tighten band clamps on the entry boot cuff
9. Inspect the ID of the concrete ring (see inside surface) and remove any debris
10. Lubricate the ID with a silicone based lubricant or spray
11. Apply a NON HARDENING pipe thread sealant to the tank riser
12. Support the concrete ring and evenly lower the spill container into place
 - a. Make sure not to move the placement of the concrete ring to grade level. If it moves, readjust to the proper height.
13. Thread on the spill container to the tank riser & tighten using the square end of the T 7106 double ended installation tool & the T 7001e T-handle.
14. Apply a NON HARDENING pipe thread sealant to ONE END of the pipe nipple and thread into the spill container
15. Install drop tube on top of the pipe nipple
16. Thread on the swivel adapter and tighten using the T 7102 orange tool & T-handle
17. Install fill/vapor dust cap

Note: Verify that when the dust cap is installed, it does not interfere with the underside of the spill container lid

18. Double check & verify the gravel guard/concrete ring assembly is still at ELEVATED grade height adjust if necessary
19. Perform the integrity testing AFTER BACKFILL but BEFORE CONCRETE
 - See Integrity Testing on Page 3
20. Install spill container cover/edge
21. Pour concrete around the Defender Series™ spill container making sure to dome the concrete at least 1" (25.4 mm) to allow for adequate runoff. The top edge of the concrete should be at the outer edge of the concrete ring tabs (Figure 8). Keep the snow plow ring and cover clean and free of any concrete spatter (the snow plow ring must be able to be removed if service is needed).

22. If equipped with a drain, adjust the position of the lower key ring on the chain so that the drain is held open when clipped up on the ledge of the snow cover ring.
23. Attach the upper most key ring to the fill/vapor dust cap.

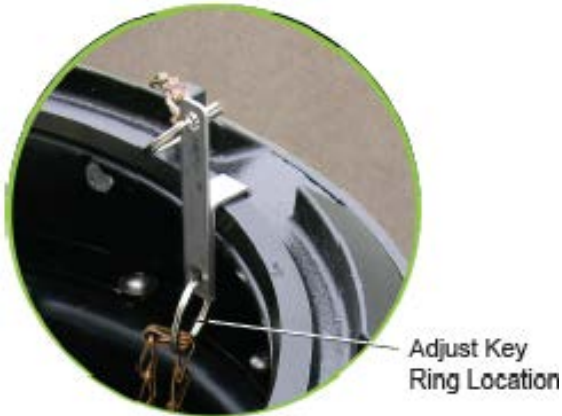

Figure 10 Drain Chain and Clip Shown installed, holding drain open

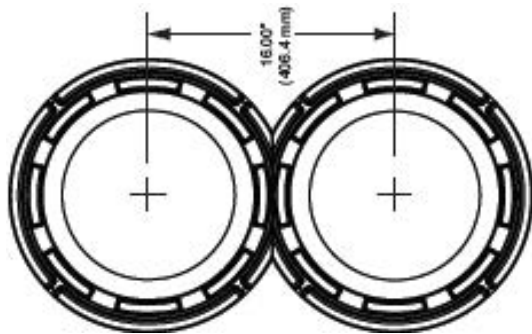

Figure 11: 16" On-Center Mounting (Top View)

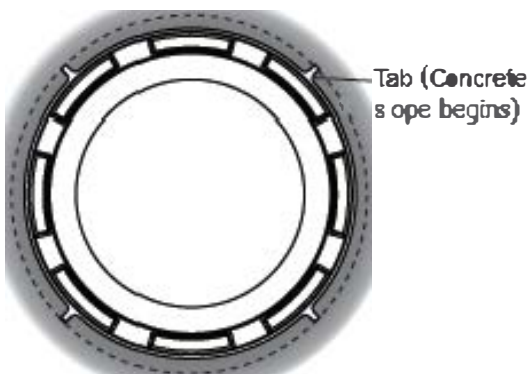

Figure 12 Concrete Placement

Integrity Testing

All Defender spill buckets are integrity tested at the factory. We recommend that the containment integrity be re-confirmed. Always test per local codes. If local codes do not specify a procedure, or refer to the manufacturer's testing, Perform Hydrostatic Test Procedure as below.

Hydrostatic Testing Procedure

1. Fill the spill bucket with water until the level is just below the upper lip of the snow cover ring.
2. After 1 hour if there is no detectable drop in water level, the spill bucket has passed the test.

Integrity Testing recommendations

Test upon installation and thereafter per local codes. Otherwise, test every 3 years.

Monthly Recommended Maintenance & Inspection Procedures

1. Clean any sand, gravel, or dirt from the snow cover ring. Buildup of material will prevent the mesh from sitting flat and diverting rain water. In addition to water infiltration, this can lead to premature lid failures and tripping hazards.
2. Inspect the cover gasket and replace it if necessary.
3. Inspect the spill container for the presence of liquid. If any is present, identify the material (water or fuel) and dispose of it using your preferred acceptable method (pump it out or drag it into the tank).
4. Inspect the primary spill container and the drain valve screen for any foreign material collecting in the bottom of the tank. Remove any large objects (leaves, rags, etc.) and wipe the bottom of the tank with a disposable rag.
5. Inspect the entire spill container assembly and components for any obvious damage. Verify that all components are functioning properly.
6. Record inspection results per local codes.

Spill Container Subassembly Replacement

Removal

1. Remove the cover.
2. Remove the snow plow ring.
 - Unthread the snow plow ring bolts using a 1/2" (13 mm) socket or nut driver until the heads of the bolts extend past the I.D. approximately 1/2" (13 mm).
 - Pull up on the snow plow ring firmly to break the seal between the O-ring and the concrete ring.
3. Remove the dust cap.
4. Remove the swivel adapter drop tube (if applicable) and pipe nipple from the spill container.
5. Remove the drop tube assembly.
6. Using the square end of the T 7106 double-ended installation tool and the T 7001 T Handle, unthread the spill container assembly.
7. Pull up firmly and evenly on the spill container to remove the spill container from the concrete ring/gravel guard.

Installation

1. Clean the I.D. of the concrete ring (sealing surface) thoroughly and re-lubricate with a silicone based O-ring lubricant or spray.
2. Apply a NON HARDENING thread sealant to the tank riser.
3. Lubricate the seal on the outside of the spill container with a silicone based O-ring lubricant or spray.
4. Evenly push down on the spill container subassembly to seat the seal ring & slide it down to where the bucket meets the tank riser.
5. Thread on the spill container subassembly to the tank riser using the square end of the T 7106 double-ended installation tool and the T 7001 T Handle.
6. Reinstall the pipe nipple.
7. Reinstall the drop tube gasket and replace if necessary.
 - Check the drop tube gasket and replace if necessary.
8. Reinstall the swivel adapter.
9. Reinstall the snow plow ring into the concrete ring.
 - Replace and lubricate the O ring.
 - Tighten the (4) bolts to the ribs on the concrete ring.

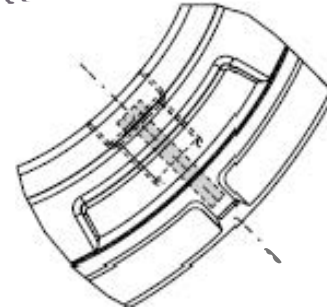

Figure 13- Snow Plow Ring Bolt Location

Push down on the snow plow ring to seat the O-ring.

Using the 1/2" (13 mm) socket or nut driver tighten the (4) bolts to the concrete ring (hand tight)

10. Reinstall the dust cap.
11. Reinstall the cover.



Franklin Fueling Systems

3700 Marsh Road
Madison WI 53718 U.S.A.
Tel +1 800 838 8788
Tel : USA & Canada 1 800 225 5797
Tel : Mexico 001 800 736 7610
www.franklinfueling.com

**Figure M-4: Defender Series Spill Container Multiport New Configuration
Installation, Operation, and Maintenance Instructions**



**Multiport Spill Containment
with Defender™ Spill Containers**

New Installation Guide Overview

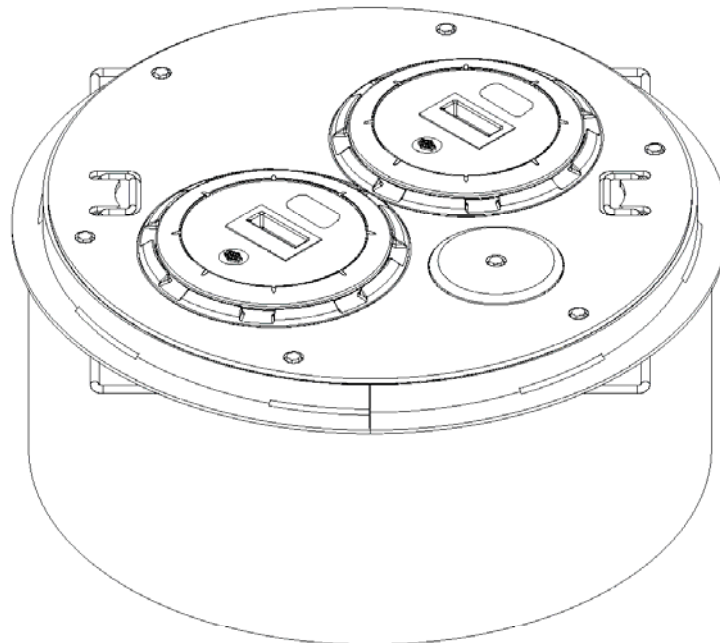

Contents

Notice.....	ii
Introduction.....	1
Multiport Safety ..	1
Tools Required for Installation ..	1
Guidelines for a Successful Installation ..	1
Fiberglass Safety ..	1
Fiberglass Tools Required for Installation ..	1
Installation Overview.....	2
Riser Installation.....	3
FFS Fiberglass Multiport Containment Sumps and Water Tight Sump Shield Installation.....	4
Fiberglass Application	4
FFS Multiport Containment Sump	4
Mixtures and Cure Times for Resin and Catalyst	5
Applying Resin and Mat to Sumps.....	5
Fiberglassing Watertight Sump Shield	6
Gel Coat Application	6
Installing Spill Bucket and Skirt.....	7
Install Cover and Concrete.....	7
Swivel Adapter/Drop Tube Installation	8

Notice

Franklin Fueling Systems (FFS) strives to produce the finest manual possible and to ensure that the information that it contains is complete and accurate. However, FFS reserves the rights to change this document and specifications at any time without notice. FFS makes no expressed or implied warranty with regard to the contents of this manual. FFS assumes no liability for errors, omissions or for any damages, direct or consequential, that may result from the use of this document or the equipment that it describes.

Inspection of Materials

Visually inspect all components for defects or damage prior to installation. If any defect or damage is found, do not use the product and contact Franklin Fueling Systems for further assistance.

Warranty Information

Please refer to the *FFS Fuel Management Systems & Product Warranty Policy* for all warranty information.

Contacting Franklin Fueling Systems (FFS)

Please feel free to contact us by mail at:

Franklin Fueling Systems
3760 Marsh Rd.
Madison WI 53718 USA

Or contact us by phone, fax or e-mail:

Tel: +1 800 225 9787

E-mail: sales@franklinfueling.com.

Fax: +1 608 838 6433

techserve@franklinfueling.com

Office and Sales Hours: 8 A.M. to 5 P.M. CST - Monday through Friday

Technical Support Hours: 7 A.M. to 7 P.M. CST - Monday through Friday

Please visit our website at www.franklinfueling.com

Introduction

This guide is meant as an installation overview for multiport spill container manways, single wall underground fiberglass sumps and water-tight sump shields. This should be used in conjunction with the appropriate part-specific installation instructions. To ensure your system integrity and safety it is essential that you follow all applicable installation instructions and the federal, state, and local codes that supersede them.

Multiport Safety

To ensure your safety, take these precautions when installing multiport spill containment devices:

- Wear steel-toed boots
- Wear work gloves
- Wear eye protection

Tools Required for Installation

- Silicone spray or Silicone O-Ring Lubricant
- Ratchet and 3/4" socket
- T-7001 T-handle wrench and T-7102 Orange Tool
- T-7106 Installation Tool for the Defender™ Spill Bucket
- T-7107 Vacuum Test Kit (Double-Wall Only)
- Tape measure
- Pipe thread sealant approved for gasoline
- Torque Wrench, 0 to 200 Ft. Lbs with 1/2" drive

Guidelines for a Successful Installation

- Do not alter the installation in any way.
- Do not install any material between the multiport containment skirt and concrete.
- Do not get debris in the D-Ring gasket channel. Failure to maintain this surface may cause improper seating of the steel diamond plate cover.
- Do not compromise the integrity of anchor points on the Skirt Ring Assembly
- Do not place fingers or toes under multiport cover while installing.
- Do make sure the multiport fill and vapor risers are 16" center-to-center. The M-1600 riser support is used to hold the risers at the proper distance.
- Do tighten the cover cam locks in a star pattern.
- Do allow concrete to encircle the multiport skirt.

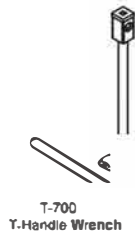

Tool Needed for Defender™ Spill Bucket

Fiberglass Safety

To ensure your safety, take these precautions when working with fiberglass sumps:

- Wear protective goggles
- Wear a protective mask (painter's mask)
- Wear hearing protection
- Protect and avoid skin contact (wear latex gloves, boots and cover all exposed skin)
- Check with local regulations concerning confined space entry

Warning ⚠ Catalyst can combust under certain circumstances. To help prevent combustion:

- Ventilate working area
- Do not use near flammable materials
- Keep out of direct sunlight
- Do not use more catalyst than required
- Do not store rags, used mats, or material that has been used to apply catalyst.

Warning ⚠ Acetone is flammable; refer to the manufacturer's instructions for complete safety information.

Fiberglass Tools Required for Installation

- Mat, resin, putty and catalyst
- FG-SEAMKIT (one per seam recommended) - see our product catalog for ordering information
- Protective gear: safety glasses, painter's mask, latex gloves and painter's suit
- Mixing stick and mixing containers for mats, resin and putty
- Grooved roller (check that it rolls freely)
- 4" to 6" disposable paintbrush
- (2) plastic resin spreaders -- one 4" and one 6" (can be purchased locally at automotive stores)
- 4" putty knife
- Acetone
- DA (Dual Action) sander (coarse, green core 40 grit sandpaper) or hand grinder

Installation Overview

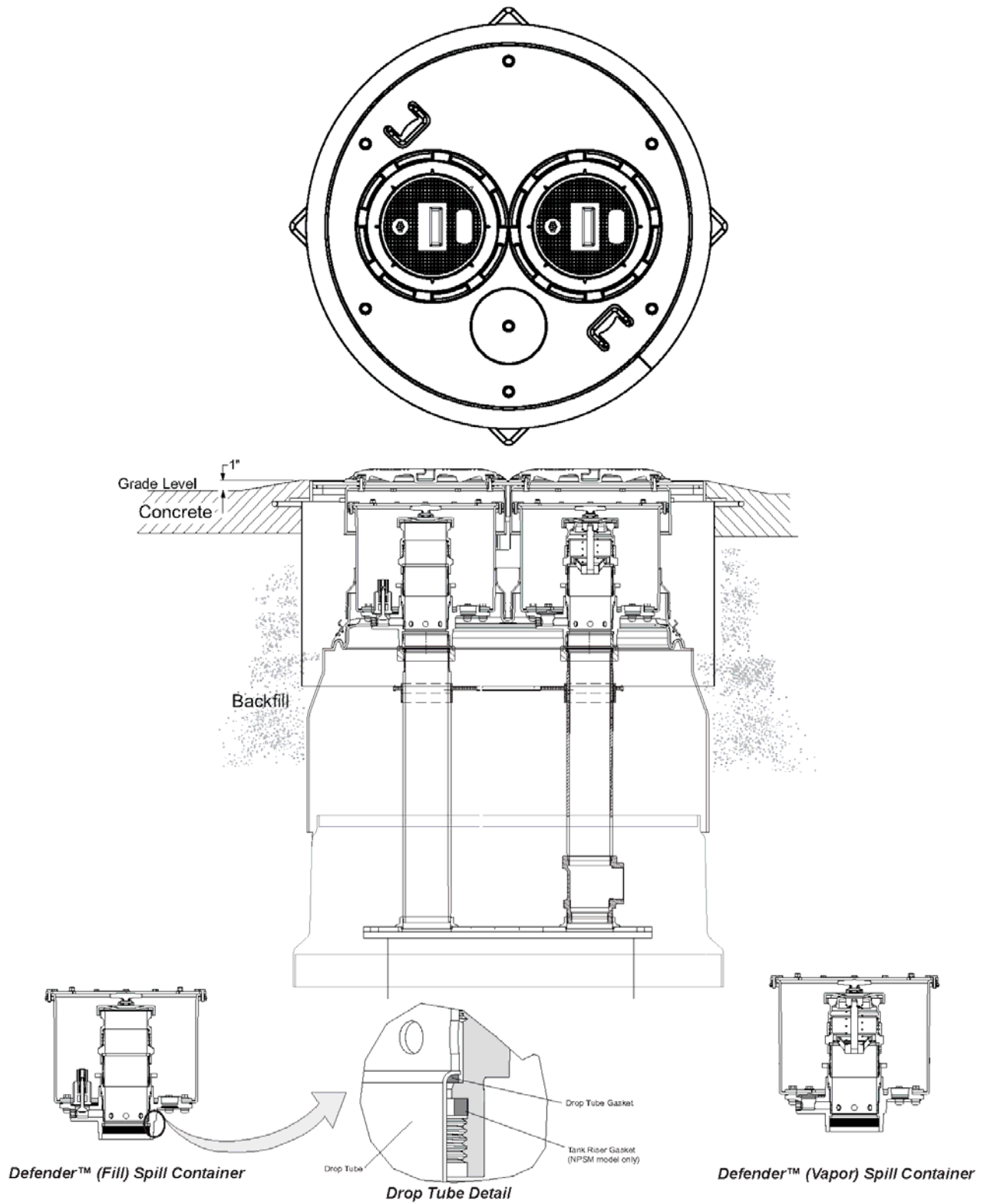

Figure 1: Installation Overview

Riser Installation

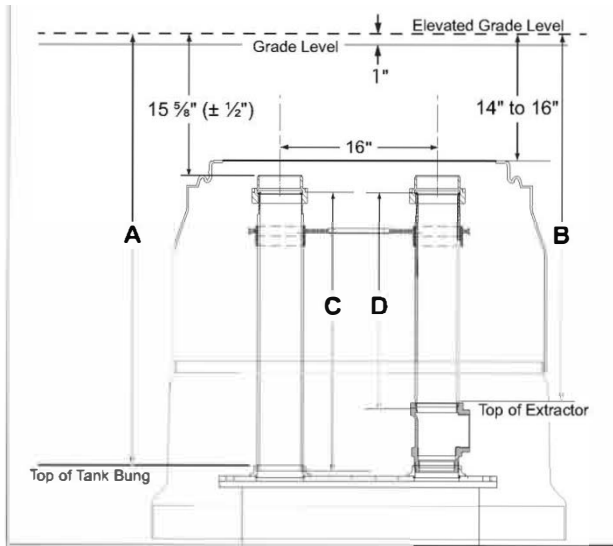

Figure 2: Installation Using M/F 4x4 Riser Adapters NPSM (Straight Thread) Buckets

Riser Dimensions

Fill Riser (C) = A - 17 3/8" = _____ (+/- 1/2")

Vapor Riser (D) = B - 17 3/8" = _____ (+/- 1/2")

Install Risers

1. Cut tank risers to length. Measurements include adding 1" slope above the grade line (Figures 2 or 3). If a different slope is used, adjust accordingly.
2. Install risers using thread sealant.
3. Install the M-1600 riser alignment bracket. This bracket ensures the proper 16" spacing between centers. This device is designed to provide no more than one inch adjustment of riser pipe spacing. The 16" spacing (Figure 4) is critical for having the manhole covers seat properly.
4. Install the M/F 4x4 adapters if applicable (Figure 5) using pipe sealant on the threads. Torque the adapter to 175-200 Ft-lbs using the T-7102 orange tool and a torque wrench.



Figure 4: Confirming Distance

Confirm the 16" spacing before proceeding.

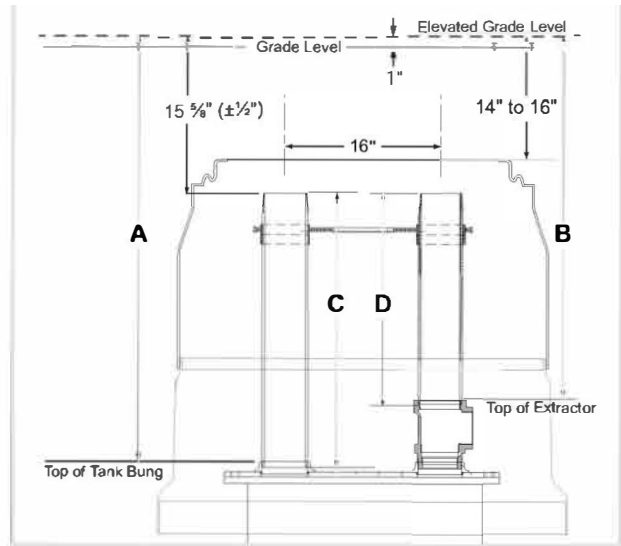

Figure 3: Installation without M/F 4x4 riser Adapters NPT (Taper Thread) Buckets

Riser Dimensions

Fill Riser (C) = A - 15 5/8" = _____ (+/- 1/2")

Vapor Riser (D) = B - 15 5/8" = _____ (+/- 1/2")

5. Re-check the height from grade to the top of the tank riser (or top of the M/F 4x4 adapter). This distance should be approximately 14 5/8" and must be between 13 3/8" and 15 7/8". (If measuring to the elevated grade, This distance should be approximately 15 5/8" and must be between 14 3/8" and 16 7/8").



Figure 5: M/F 4x4 Adapters Fitted

Installing Fiberglass Riser

1. Dry fit the fiberglass riser onto the fiberglass sump to obtain proper height.
2. Cut the riser to length
 - a. If installing without a sump shield, cut the fiberglass riser/collar so it is at least 2" above the top of the tank riser or M/F 4x4 riser adapter.
 - b. If installing with an FFS water-tight sump shield, cut the fiberglass riser so the top edge is approximately 14" from grade (13" to 15").

FFS Fiberglass Multiport Containment Sumps and Water Tight Sump Shield Installation

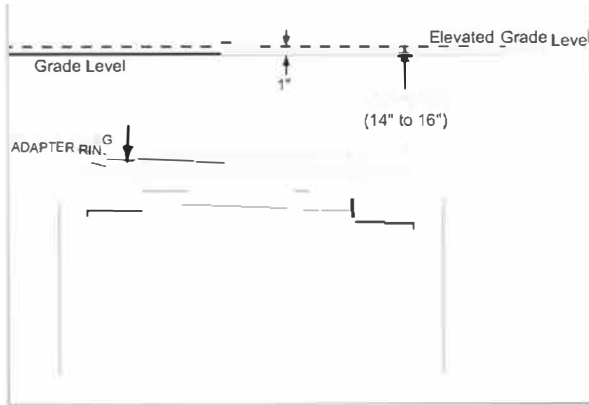

Figure 6: Dry-Fit Non-FFS Sump

Fiberglass Application

FFS Multiport Containment Sump

Preparation

1. Abrade, down to the glass fibers, four inch tall segments on the two components being fiberglassed together.
2. The fiberglass sump should be sanded using a power sander with coarse, green core 40 grit sandpaper (Dual Action Sander works best). If you're going to be sanding by hand, use an abrasive medium to make a rough surface for the fiberglass to bond to.
3. Use a tack rag to remove dust.
4. Wipe abraded areas with acetone to help the mat adhere to the abraded areas.
5. Test fit the sump shield and spill buckets (hand-tight) to keep the fiberglass riser aligned while adhering to the fiberglass sump base (Figure 7).

Applying Putty to Sump Joints

1. Clear the inside and outside of the joint of debris so that the area is completely dry and clean.
2. Mixing putty and catalyst:
 - a. The putty and catalyst mixing ratio is 20 mL of catalyst per one quart of fiberglass putty. Use a measuring beaker or cup to measure out the 20 mL of catalyst.
 - b. For best results, ambient temperature should be above 70° F when fiberglassing. If the ambient temperature is below 70° F, cure times will be longer and the catalyst ratio must be adjusted when mixing putty with resin.
 - c. When mixing putty and catalyst, always mix from the bottom up.
 - d. Mix the catalyst and putty together until the catalyzed putty is thoroughly, uniformly mixed with no color streaks.

3. Smoothly apply the catalyzed putty with a 4" putty knife to the outside joint of the sump, pushing some down into the joints. Fill in any open areas of the joint with catalyzed putty.
4. Create a smooth surface for the mat to bond to by using a plastic resin spreader to smooth the catalyzed putty around the joint. Make sure that there are no cracks or holes in the putty because this layer is what creates the watertight bond to the sump.



Figure 7: Aligning Multi-Port Sump Shield

5. Allow the puttied sump to sit for at least one hour in an above 70° F environment so that the putty can harden. **Do not disturb the sump during this time, or it could become misaligned.** Lower temperatures will require longer cure times.
6. Inspect the outside joint for gaps that could cause a problem for the mat when adhering it to the abraded area of the sump. Visually inspect the inside joint to verify that there are no problem areas, cracks or holes.
7. After the joint has fully cured, lightly sand all previously abraded areas, dust them off, and wipe down the area with an acetone-soaked rag.



Figure 8: Applying Putty and Catalyst

Mixtures and Cure Times for Resin and Catalyst
Important Things to Know

Resin hardens quickly, so have all setup items prepared ahead of time. Spending extra time on setup items prior to mixing the resin will help ensure that you have enough time later to work with the resin before it hardens. Before mixing resin, check that your roller works properly. For best results, ambient temperature should be above 70° F. If the ambient temperature is below 70° F, curing time will be extended (refer to the time chart for approximate cure times).

Resin/Catalyst Mixtures

Resin	Catalyst in cool or overcast conditions:	Catalyst in standard conditions:	Catalyst in hot or sunny conditions:
	2% per weight	1.6% per weight	1% per weight
16 fl. oz. (1 pt.)	9 mL	7 mL	5 mL
32 fl. oz. (1 qt.)	19 mL	14 mL	9 mL

Cure Times

Cure times given are for reference purposes only, exact times may vary

Ambient Temperature	Minimum Set-up Time
35 F	20 Hours
40 F	14 Hours
50 F	8 Hours
60 F	5 Hours
70 F	3 Hours
80 F	2 Hours
90 F	1 Hour
100 F	½ Hour

1. Cut several dozen pieces of fiberglass mats to lengths of 24". These mats will be used in the next section, but it's important to do this before mixing the resin to give yourself more time to work with the resin before it hardens.
2. Mix one pint of catalyzed resin at a time, starting with a small amount so that the mixture does not cure before applying it to the sump. As you become more familiar with the fiberglass application, you may increase the amount to one quart.

Note: Do not use less than 1% per weight of catalyst per mixture, or the resin will not fully bond to the surface of the sump and mat.

Applying Resin and Mat to Sumps

When applying mats to a sump, use three layers of fiberglass mat strips (the ones you cut in Step 1 in the *Mixtures and Cure Times for Resin and Catalyst* section) for each joint of the sumps being fiberglassed. Apply one layer of mat at a time, centering and overlapping the mats on the joint being fiberglassed.

Note: Do not store mats in humid or wet environments. If a mat comes in contact with liquids or humidity it will begin to release the chemicals that allow it to adhere to the fiberglass sump. A wet or damp mat will not adhere to a sump and should be disposed of immediately.

1. Apply catalyzed resin generously to the puttied sump joint using a disposable paintbrush that is 4" or 6" wide. Wet out (apply a large amount of catalyzed resin to) the area on the components being fiberglassed more than large enough for the 24" piece of mat to lay on (Figure 9).



Figure 9: Apply Resin

2. Apply a fiberglass mat to the area wetted out in Step 1 and saturate this layer of mat with catalyzed resin.
3. Using a 4-6" grooved roller, roll over the layer of fiberglass mat and remove any air bubbles. Make sure that air bubbles are not present in this layer because this layer is the foundation for the next layer. White areas in a mat indicate the presence of air pockets.
4. Roll over the mat horizontally and vertically with the roller as many times as needed to eliminate air bubbles (Figure 10).



Figure 10: Remove Air Bubbles on Containment Sump

5. Repeat Steps 1 through 4 all of the way around these sump, overlapping each mat with the one previously applied. Three layers of mat need to be applied to each sump joint.

Note: Resin will soak through the first layer: don't apply as much resin to the second and third layers as on the first.

Note: Clean the roller with acetone periodically so that it keeps rolling freely.

6. Finalize the mat install by spreading some extra resin across the mat. Again, remove any air pockets that may be caught in the resin.
7. Refer to the Cure Times chart for approximate cure times.

Fiberglassing Watertight Sump Shield



Figure 11



Figure 12

Note: Apply fiberglass to both the inside and outside of the watertight sump shield (Figures 11 & 12).

Gel Coat Application

Tools

- NIOSH approved respirator
- Disposable paint brush or roller
- Disposable bucket for mixing
- Mixing sticks
- Gel Coat LHM 2900 Low Hap White HydroShield Lite NPG/ISO Marine Gel Coat (available from HK Research). Check this link for information: www.hkresearch.com/gel_coats_aa
- Catalyst
- Tacky rags
- Acetone to clean and prepare surface

Safety Considerations

- The white gel coat contains styrene monomer, which is a flammable liquid. Keep away from sparks, heat and open flame.
- Styrene vapors are heavier than air. Use adequate ventilation or suction fans to remove vapors.
- Both the polyester gel coat and the catalyst may cause burns to eyes and skin. Do not get in the eyes.
- Avoid breathing vapors! Gel coat applicators should wear a NIOSH approved respirator effective for vapors, spray mist and dust. In case of accidental contact, remove contaminated clothing and wash affected skin areas with soap and copious quantities of water. Contact a physician if a persistent skin irritation occurs. For eyes, immediately flush with plenty of water for at least 15 minutes; call a physician immediately. Wash contaminated clothing before reusing.

Note: Do not mix material continuously or its thixotropic properties may be lost (Certain gels become more fluid when over-stirred). If the gel coat is inadvertently over mixed, hold material for four hours without agitation before application.

Mixing

- The catalyst concentration used in the application of the "LHM" series NPG-ISO White Gel Coats should not exceed 3.0% or fall below 1.5% to retain maximum properties.
- The recommended range for the catalyst concentration within the applied film is 1.8 to 2.2% at 77°F.
- Recommended catalysts are NORAC MEKP9, Superox 46702 and Cadco L 50a. Call HK's Lab for other recommendations.

Application

1. Use sandpaper to rough up the surface and remove the shiny surface of the existing gel coat layer.
2. Use a tacky rag to remove dust on the surface to be gela coated.
3. Clean area with acetone and let dry.
4. After mixing resin and catalyst, apply it using a disposable brush or roller. Coat the area thoroughly and allow the gel coat to set. The time required for the gel coat to set is dependent upon the temperature and the percent of catalyst mixed into resin.
5. Inspect the area for full coverage. Paint on additional coats to ensure full coverage.

Finishing

1. After the fiberglass has cured, lightly sand the area (preferably by hand using coarse, green core 40 – 60 grit sandpaper) to remove all excess fiberglass material.
2. Dust the sump clean.

Clean-Up

Putty knives, grooved rollers

Warning



Take care when disposing of these clean-up items because they are highly flammable.

Storage Limitations of Catalyst, Resin and Mat

- Do not store mat in a humid or wet environment. If mat comes in contact with humidity or liquid, it will begin to release the chemicals that allow it to adhere to the fiberglass sump. A wet or damp mat will not adhere to a sump and should be disposed immediately.
- Three months after manufacture at 73°F or below in a factory sealed container.
- Keep out of direct sunlight.

Warning



Catalyst can combust under certain circumstances. To help prevent combustion: do not store rags, used mats, or material that has been used to apply catalyst; adequately ventilate areas when working with materials; do not use near flammable materials; keep out of direct sunlight and do not use more catalyst than required when mixing with resin.

Installing Spill Bucket and Skirt

1. Remove hand-tight spill buckets from the tank risers.
2. Install the reducer boots and band clamps onto the spill bucket (if applicable).
3. Reinstall the spill buckets onto tank risers.
 - a. If using NPSM (straight threads) buckets, apply grease or anti-sieze compound onto the threads of the M/F 4x4. Torque buckets to 75-100 Ft Lbs using the T-7106 tool.
 - b. If using NPT (taper thread) buckets, apply a non-hardening pipe thread sealant to the tank riser threads. Tighten bucket using the T-7106 tool.
4. Adjust reducer boots onto the water-tight sump shield and tighten band clamps (If applicable).
5. Backfill around the multiport sump until approximately 18" from grade level.
6. Place skirt ring (without manhole cover) around the multiport sump.

Install Cover and Concrete

1. Before installing the multiport cover make sure the:
 - a. D-ring gasket is free of dirt and debris, the round edge is facing up, and it is fully seated in the skirt channel Figure 13

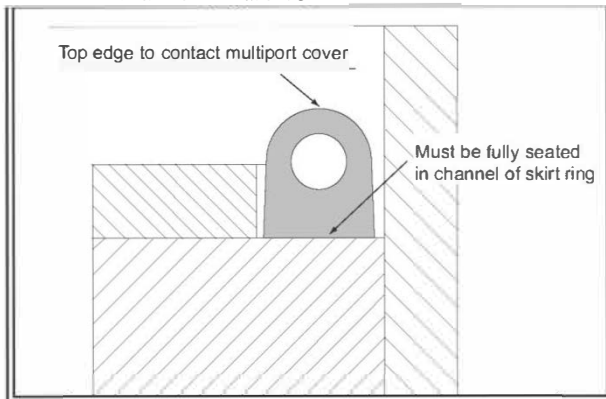

Figure 13: D-Ring Gasket Cross Section

- b. Cam locks are fully open with the long edge against the stop (Figure 14)



Figure 14: Cam Lock Open

2. Lubricate the inside of the spill bucket sleeves (on the manhole cover) with silicone spray or silicone O-ring lubricant.
3. Carefully install the cover over the spill buckets and let it rest on top of the spill buckets (Figure 15).



Figure 15: Installing Diamond Plate Cover

4. Raise the skirt ring up to the manhole cover and tighten cam-locks. This will center the skirt ring to the spill containers.
5. Seat the cover inside the skirt ring & against the d-ring gasket as much as possible before tightening the cam locks. This will ensure the cam swings underneath the cam ring (Figure 16 and draws the cover downward to fully seat against the d-ring gasket.



Figure 16: Cam Lock Closed and Engaged

6. To secure the manhole cover, tighten down the (6) cam-locks in a star/crossing pattern.
7. Pour the rest of the backfill around the skirt ring until the concrete depth is achieved.

8. Perform final height adjustment of the manhole cover to elevated grade (approximately 1" above grade for proper run-off as in Figure 17). Make sure backfill supports the assembly so it doesn't move during the concrete pouring.

Important! Doublecheck the distance between the top of the spill bucket to the underside of the sleeve. This dimension must be between 3/4" and 3 3/8"

9. Finish Concrete.

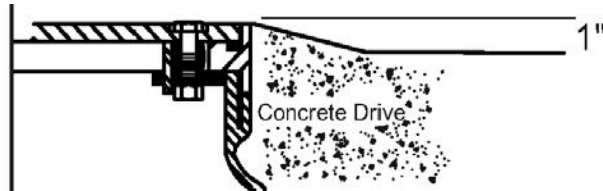

Figure 17: Concrete Slope from Cover

Important! Double check the distance between the top of the spill bucket to the underside of the sleeve. This dimension must be between (3/4" – 3 3/8").

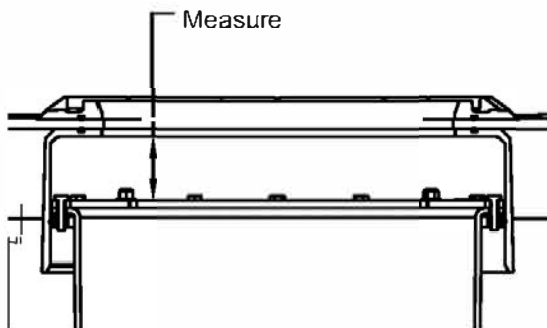

Figure 18: Measure Clearance

Swivel Adapter/Drop Tube Installation

1. Remove the DT riser clamp assembly (Figures 19 and 20) using the notched end of the double-ended installation tool (T-7106).
2. Install swivel fill/vapor adapter using a close nipple and pipe thread sealant to the end threading into the DT riser clamp. Torque to 50.75 ft lbs.
3. Insert the drop tube/overflow prevention valve assembly & gasket into the bucket (if applicable).
 - a. If the tank riser length was changed, a retrofit M/F 4x4 was installed, or if the drop tube was previously installed underneath the swivel adapter – a new upper drop tube will need to be cut to the appropriate length.
4. Install the DT riser clamp assembly and torque to 50.75 ft-lbs using the notched end of the double-ended installation tool (T-7106).

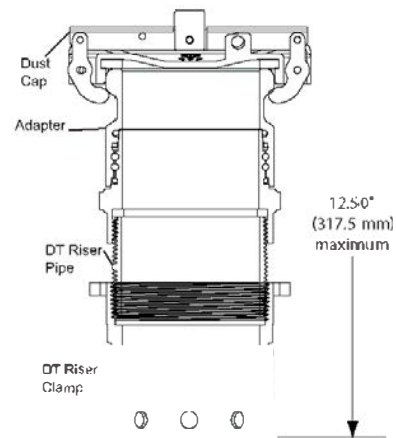

Figure 19: Drop Tube (DT) Riser Clamp Assembly Dimensions

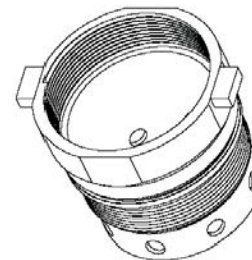

Figure 20: Drop Tube Riser Clamp



3760 Marsh Road • Madison, WI 53718, U.S.A.
Tel: +1 608 838 8786 • Fax: +1 608 838 6433
Tel: USA & Canada 1 800 225 9787 • Tel: México 001 800 738 7610

Franklin Fueling Systems GmbH
Rudolf-Diesel-Strasse 20 • 54516 Wittlich, GERMANY
Tel: +49-6571-105-380 • Fax: +49-6571-105-510

Figure M-5: Defender Series Spill Container Multiport Retrofit Configuration Installation, Operation, and Maintenance Instructions



Multiport Spill Containment with Defender™ Spill Containers

Retrofit Installation Guide Overview

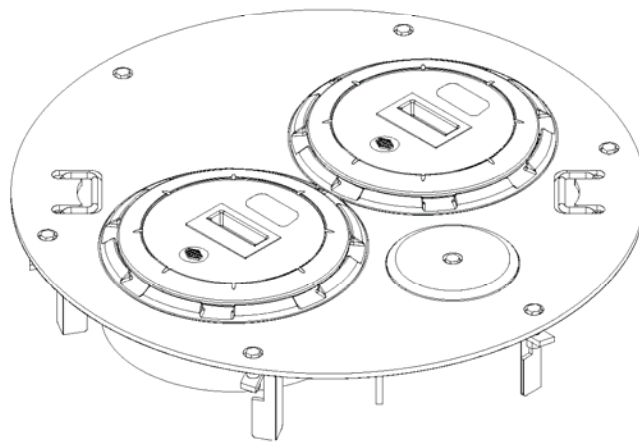

Contents

Introduction	1
Multiport Safety	1
Tools Required for Installation	1
Guidelines for a Successful Installation	1
Installation Overview	2
Retrofit Verification	3
Existing Multiport Disassembly	3
Tank Riser Preparation	3
Riser Installation	3
Installing Spill Buckets	4
Cover Installation	4
Swivel Adapter/Drop Tube Installation	5

Notice

Franklin Fueling Systems (FFS) strives to produce the finest manual possible and to ensure that the information that it contains is complete and accurate. However, FFS reserves the right to change this document and specifications at any time without notice. FFS makes no expressed or implied warranty with regard to the contents of this manual. FFS assumes no liability for errors, omissions or for any damages, direct or consequential, that may result from the use of this document or the equipment that it describes.

Inspection of Materials

Visually inspect all components for defects or damage prior to installation. If any defect or damage is found, do not use the product and contact Franklin Fueling Systems for further assistance.

Warranty Information

Please refer to the *FFS Fuel Management Systems & Product Warranty Policy* for all warranty information.

Contacting Franklin Fueling Systems (FFS)

Please feel free to contact us by mail at:

Franklin Fueling Systems
3760 Marsh Road
Madison, WI 53718 USA

Or contact us by phone, fax or e-mail:

Tel: +1 800 225 9787

E-mail: sales@franklinfueling.com

Fax: +1 608 838 6433

techserve@franklinfueling.com

Office and Sales Hours: 8 A.M. to 5 P.M. CST - Monday through Friday

Technical Support Hours: 7 A.M. to 7 P.M. CST - Monday through Friday

Please visit our website at www.franklinfueling.com

Introduction

This guide is meant as an installation overview for multiport spill container manways, single wall underground fiberglass sumps and water-tight sump shields. This should be used in conjunction with the appropriate part-specific installation instructions. To ensure your system integrity and safety, it is essential that you follow all applicable installation instructions and the federal, state, and local codes that supersede them.

Multiport Safety

To ensure your safety take these precautions when installing multiport spill containment devices:

- Wear steel toed boots
- Wear work gloves
- Wear eye protection

Tools Required for Installation

- Silicone spray or Silicone O-Ring Lubricant
- Ratchet and 3/4" socket
- T-7043 Spill Container Tool Kit
- T-7106 Installation Tool for the Defender™ Spill Bucket
- T-7043 Vacuum Test Kit (Double-Wall Only)
- Tape measure
- Pipe thread sealant approved for gasoline
- Torque Wrench, 0 to 200 Ft Lbs with 1/2" drive

Guidelines for a Successful Installation

- **Do not** alter the installation in any way
- **Do not** get debris in the D-Ring gasket channel. Failure to maintain this surface may cause improper seating of the steel diamond-plate cover.
- **Do not** place fingers or toes under multiport cover while installing
- **Do** make sure the multiport fill and vapor risers are 16" center-to-center. The M-1600 riser support is used to hold the risers at the proper distance.
- **Do** tighten the cover cam-locks in a star pattern.

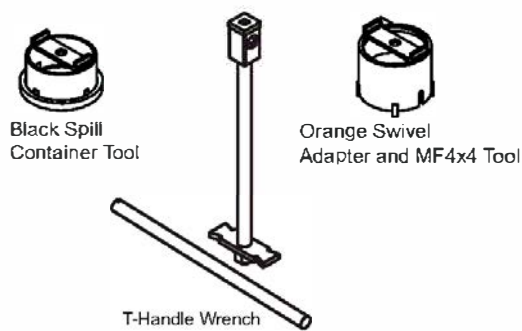

T-7043 Tool Kit Contents

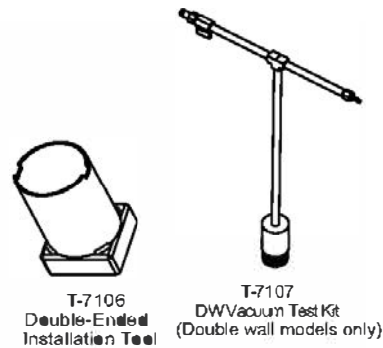

Tool Needed for Defender™ Spill Bucket

Installation Overview

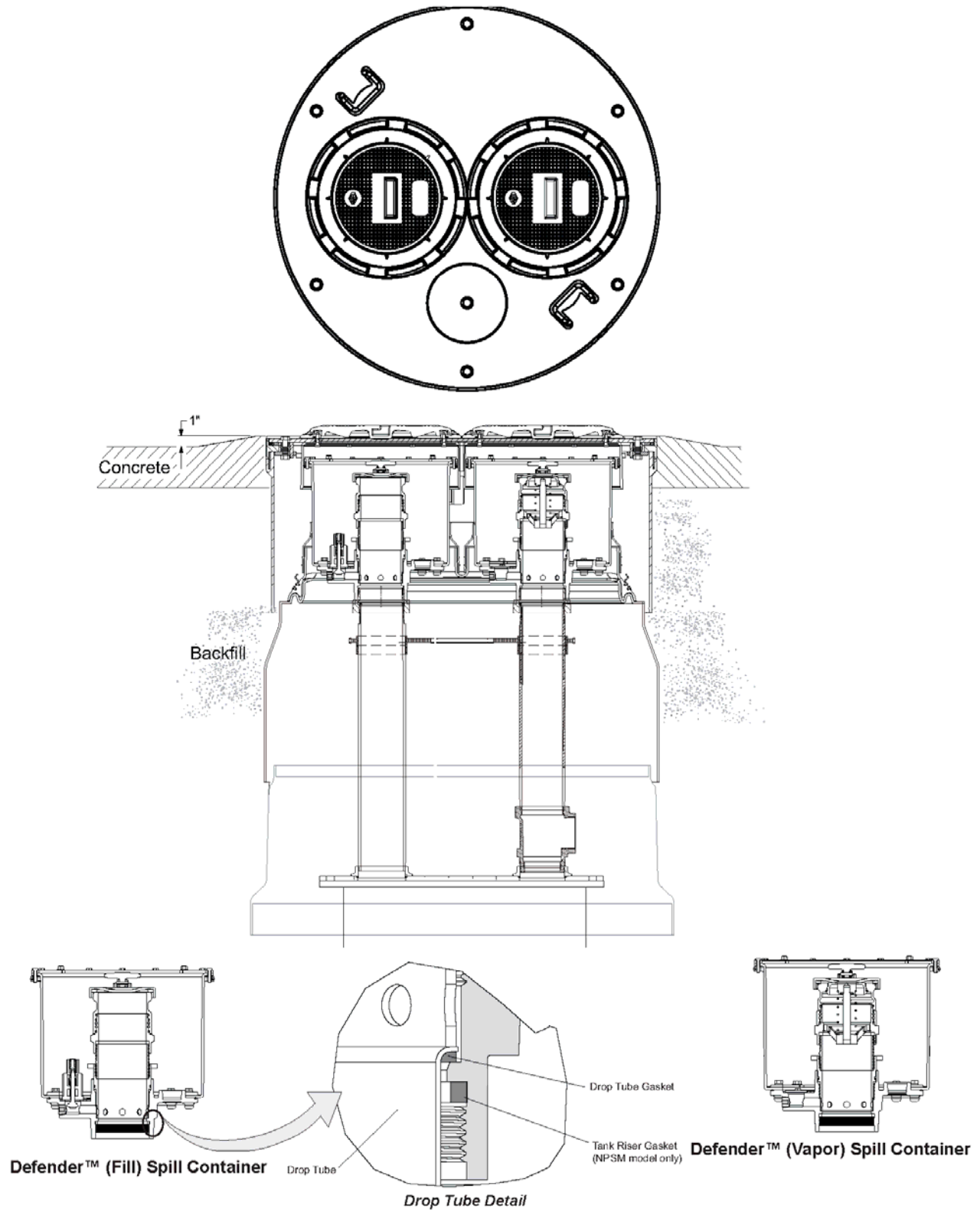

Figure 1: Multiport Installation Overview

Riser Installation

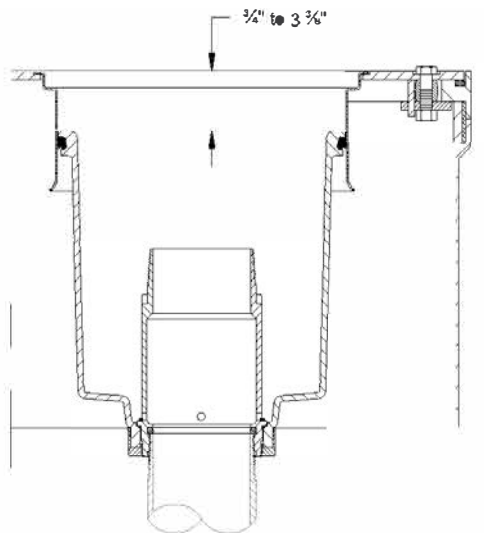

Figure 2: Measure Spill Bucket Clearance

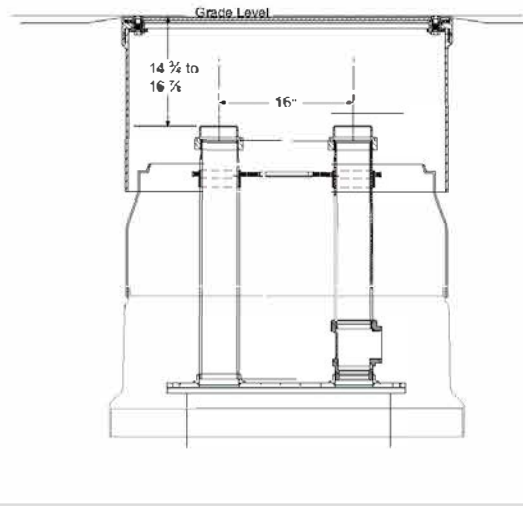

Figure 3: Installation Using M/F 4x4 Riser Adapters NPSM (Straight Thread) Buckets

Stop! – Before disassembling the existing Phil-Tite multipoint, verify that the risers are within range for the new Defender Series™ buckets.

Retrofit Verification

1. Measure the top of the stainless steel sleeve to the top of the spill bucket (Figure 2)
 - a. 85100 series (3.5 gallon) bucket = (1 3/4" – 4 1/4")
 - b. 85100-1 series (5 gallon) bucket = (3/4" – 3 1/4")
2. If the measurement falls within the range listed, then you will probably not need to adjust the tank riser length
 - a. If the measurement is too small (tank riser too long), then the riser will need to be cut shorter
 - b. If the measurement is too big (tank riser too short), then a longer riser will need to be installed or a retrofit riser adapter (adds 1 3/4")

Existing Multipoint Disassembly

1. Remove existing manhole cover
2. Loosen the band clamps on the reducer boots (if applicable)
3. Remove the Phil Tite spill buckets using the black spill bucket tool
4. Remove the drop tube & overflow prevention device (if applicable)
5. Remove watertight sump lid (if applicable)

Tank Riser Preparation

1. Place a straight edge over the top of the manway opening and measure the distance to the top of the M/F 4x4
 - a. If the distance is between 14 3/8" and 16 7/8", then the tank risers can be reused
 - b. If the distance is less than 14 3/8", shorten riser length so the final distance, including the M/F 4x4 is 15 5/8" (+/- 1/2")
 - c. If distance is between 16 7/8" and 18 5/8", install retrofit riser adapter on top of existing M/F 4x4 riser adapter – torque to 125-150 ft-lbs using the T-7102 orange tool and torque wrench
 - d. If distance is more than 18 5/8", cut new risers to 17 3/8" +/- 1/2" from grade (M/F 4x4 will add 1-3/4" to achieve a final distance of 15 5/8") Reinstall M/F 4x4 – torque to 125-150 ft-lbs using the T-7102 orange tool and torque wrench
2. Adjust the M-1600 riser alignment brackets to ensure 16" on-center spacing of the tank risers (Figure 4). **This is critical for having the manhole cover to fit properly over the spill buckets.**



Figure 4: Confirming Distance

Installing Spill Buckets

1. Install water tight sump shield (if applicable).
2. Install the small end of the reducer boot and smaller band clamp onto defender spill bucket (if applicable).
3. Thread on the new defender spill buckets on to the tank risers.
 - a. If using NPSM (straight threads) buckets, apply grease or anti-sieze compound onto the threads of the M/F 4x4. Torque buckets to 75-100 Ft Lbs using the T-7106 tool.
 - b. If using NPT (taper thread) buckets, apply a non-hardening pipe thread sealant to the tank riser threads. Tighten bucket using the T-7106 tool.
4. Adjust reducer boots onto the water-tight sump shield and tighten band clamps (If applicable).

Cover Installation

1. Before installing the multiport cover make sure the:
 - a. D-ring gasket is free of dirt and debris, the round edge is facing up, and it is fully seated in the skirt channel Figure 5

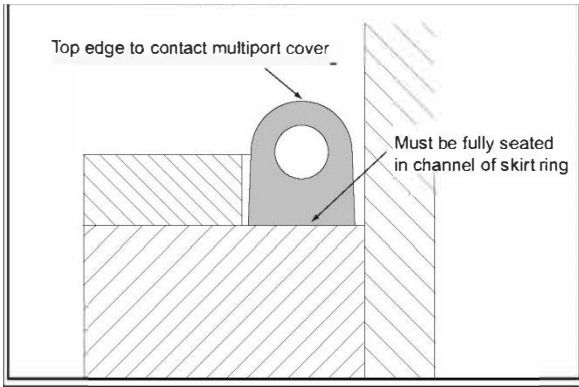

Figure 5: D-Ring Gasket Cross Section

- b. Cam locks are fully open with the long edge against the stop (Figure 6)



Cam Stop



Figure 6: Cam Lock Open

2. Lubricate the ID of the manhole cover sleeves with silicone spray or silicone based O-ring lubricant.

3. Install the manhole cover into the multiport, making sure to properly align the spill buckets to the sleeves.
4. Seat the cover inside the skirt ring & against the d-ring gasket as much as possible before tightening the cam locks. This will ensure the cam swings underneath the cam ring (Figure 7) and draws the cover downward to fully seat against the d-ring gasket.



Figure 7: Cam Lock Closed and Engaged

5. To secure the manhole cover, tighten down the (6) cam-locks in a star/crossing pattern.

Important! Double check the distance between the top of the spill bucket to the underside of the sleeve. This dimension must be between ($\frac{3}{4}$ " – 3 $\frac{3}{8}$ ").

Measure

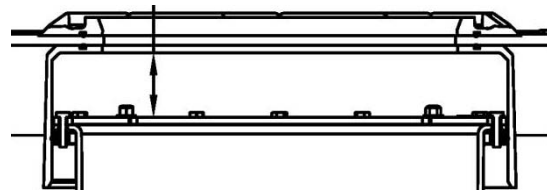

Figure 8: Measure Clearance

Swivel Adapter/Drop Tube Installation

1. Remove the DT riser clamp assembly (Figures 9 and 10) using the notched end of the double-ended installation tool (T-7106).
2. Install swivel fill/vapor adapter using a hose nipple and pipe thread sealant to the end threading into the DT riser clamp. Torque to 50-75 ft lbs.
3. Insert the drop tube/overflow prevention valve assembly & gasket into the bucket (if applicable).
 - a. If the tank riser length was changed, a retrofit M/F 4x4 was installed, or if the drop tube was previously installed underneath the swivel adapter – a new upper drop tube will need to be cut to the appropriate length.
4. Install the DT riser clamp assembly and torque to 50-75 ft lbs using the notched end of the double-ended installation tool (T-7106).

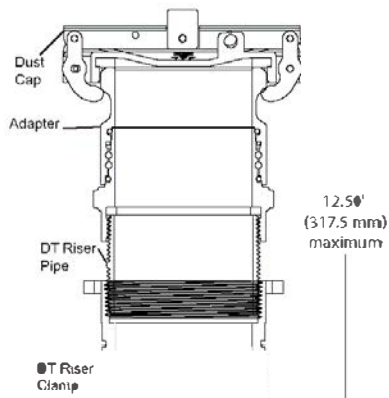

Figure 9: Drop Tube (DT) Riser Clamp Assembly Dimensions

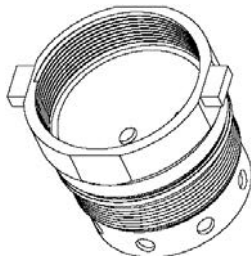

Figure 10: Drop Tube Riser Clamp



3760 Marsh Road • Madison, WI 53718, U.S.A.
Tel: +1 608 838 8786 • Fax: +1 608 838 6433
Tel: USA & Canada 1 800 225 9787 • Tel: México 001 800 738 7610

Franklin Fueling Systems GmbH
Rudolf-Diesel-Strasse 20 • 54516 Wittlich, GERMANY
Tel: +49-6571-105-380 • Fax: +49-6571-105-510

Figure M-6



Below Grade Spill Containment Manholes

705 - 5 Gallon 715 - 15 Gallon 725 - 25 Gallon

Installation Instructions

Warning  Application and use of this product should be in compliance with local, state, and federal regulations. Selection of this product should be based on physical specifications, limitations, and compatibility with the environment and material to be handled. EBW makes no warranty of fitness for a particular use.

Manual #	Revision	Date	Changes from Previous Revision
F-1306	4	Mar. 2012	Removed reference to thread sealant branding. Removed obsolete Shallow Burial Sump

Franklin Fueling Systems • 3760 Marsh Rd • Madison, WI 53718 USA
 Tel: +1 608 838 8786 • 800 225 9787 • Fax: +1 608 838 6433 • www.franklinfueling.com

Part No.	Size	Base	Drain	Replacement Drain Valve Kit	Fig.
705-445-01	5 Gal.	Cast Iron	Cover Actuated Push Drain	705-225-02	A
705-445-65	5 Gal.	Cast Iron	Cover Actuated Push Drain	705-225-02	A
705450-01	5 Gal.	Cast Iron	Auto-Drain	705-120-01	A
705-455-01	5 Gal.	Cast Iron	Cover Actuated Push Drain	705-225-02	A
705457-01	5 Gal.	Cast Iron	Auto-Drain	705-120-01	A
705-474-01	5 Gal.	Cast Iron	Pull to Push	705-332-19	A
705474-65	5 Gal.	Cast Iron	Pull to Push	705-332-19	A
705475-01	5 Gal.	Composite	Pull to Push	705-332-01	A
705-475-65	5 Gal.	Composite	Pull to Push	705-332-19	A
705-438-06	15 Gal.	Cast Iron	Auto-Drain	705-120-01	C
715446-01	15 Gal.	Cast Iron	Cover Actuated Push Drain	705-225-01	C
715-446-65	15 Gal.	Cast Iron	Cover Actuated Push Drain	705-225-01	C
715-456-01	15 Gal.	Cast Iron	Cover Actuated Push Drain	705-225-01	C
715474-01	15 Gal.	Cast Iron	Pull to Push	705-332-19	C
715-474-65	15 Gal.	Cast Iron	Pull to Push	705-332-19	C
715-475-01	15 Gal.	Composite	Pull to Push	705-332-19	C
715-475-65	15 Gal.	Composite	Pull to Push	705-332-19	C
725447-01	25 Gal.	Cast Iron	Cover Actuated Push Drain	705-225-03	E
725-474-01	25 Gal.	Cast Iron	Pull to Push	705-332-19	E
725-475-01	25 Gal.	Composite	Pull to Push	705-332-19	E
725-475-65	25 Gal.	Composite	Pull to Push	705-332-19	E

ARB approved EVR components listed on page 7.

The following items may be ordered separately:

Test Drain Kits (no drain) #90022 for models with pull to push drains and push drains

Replacement Drain Valves for Models with Pull Drains

Part #	Size	Below Grade or Grade Level
705-336-01	5 Gal.	Below Grade & Grade Level
705-336-02	15 Gal.	Below Grade & Grade Level
705-336-03	25 Gal.	Below Grade
705-336-04	25 Gal.	Below Grade & Grade Level

Conversion Drain Valve Kit for Models with Push Drains Order Conversion Kit 705-332-99

Notice For New York City Approval

715-474 Models

The 715-474 (15 Gallon) spill containment has been assigned the certificate of approval number (5021) by the New York City Fire Department, and its installation and use is subject to the following conditions and pursuant to 27-4015 of the New York City Bureau of Fire Prevention Code.

1. The installation and use of these Below Grade Spill Containment Manholes (Fill Boxes) shall comply with all applicable requirements of New York Fire Prevention Code, Fire Prevention Rules Building Code, 40 CFR Part 280.20 and 280.30 pertinent to 27-4065-F of New York City Fire Prevention Code.
2. Prior to use, all installations shall be subject to inspection by the Bureau of Fire Prevention which may result in added requirements being imposed.

Installation Instructions

Before installing a spill container, coat all of the riser pipe threads with a thread sealant that is compatible with the product in that tank.

Install spill container by threading it onto the tank riser pipe until it is handtight. Do not use the upper cast iron ring to fully tighten the spill container. Tightening the tank using the upper cast iron ring can cause undue stress to the entire unit.

After handtightening, place a torque wrench assembly around the lower portion of the tank base and torque the spill bucket base on a riser pipe to 60 - 90 ft. lbs. torque using an EBW chain wrench (part #901-101-01) and a torque wrench with at least 100 ft. lbs. of torque range (due to an offset of chain and torque wrenches, actual torque wrench values will be 45 - 70 ft. lbs.). After an initial torque value is obtained, continue to thread the tank base onto the riser pipe until the drain is orientated to the riser low spot.

Note: All of the tank risers have some out-of-plumb characteristics due to slight tank tilts and rolls. To properly drain, the drain valve must be located at the low spot of the riser tilt. The riser low spot is the direction the riser pipe is leaning towards. This is easily obtained by placing a small amount of water in the bucket base and turning the bucket until the water runs to the drain valve.

If space is limited (i.e. a retrofit installation to a sawed out section of concrete):

1. Make sure that the inside riser pipe is removed.
2. Locate the fitting that the inside riser pipe threads into.
3. Coming down through the top of the unit, use a special socket wrench on the octagonal surface of the fitting to finish tightening it. Do not disassemble the unit.

Note: Use the Styrofoam Locator (part #705-417) for installation (see Figure B). Do not discard it. After installation is complete, remove the locator from the manhole.

Check For Leaks

Every unit should be tested for leaks prior to, and after, pouring concrete. If this model comes with a drain, close it. If not, install a 90022 test drain kit. Fill the unit completely with water. If the test water level drops at all within one hour, then a leak exists (this is not an EVR test).

Check to see that the drain valve is seated properly. If not, then **pull** the drain valve several times on a **pull to push drain unit**. Replace the valve if it continues to leak.

If the unit continues to leak, the entire spill container must be removed from the riser pipe and replaced with another. **Re-test**

After backfilling the area with pea gravel and pouring concrete, **re-test** to make sure that no damage occurred during installation.

5 Gallon Spill Containers

Figure A

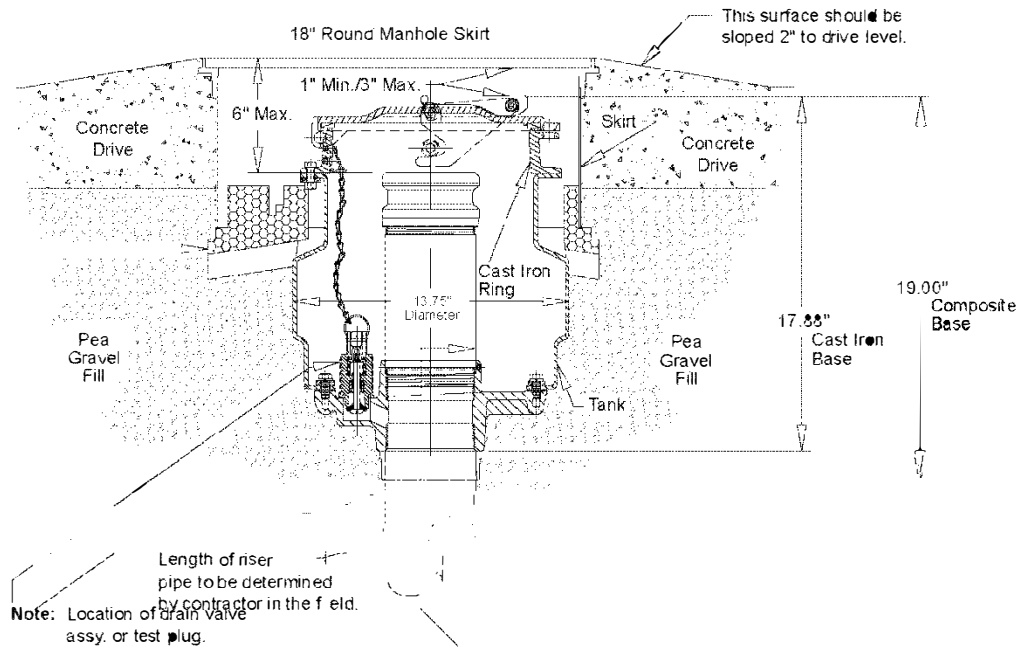
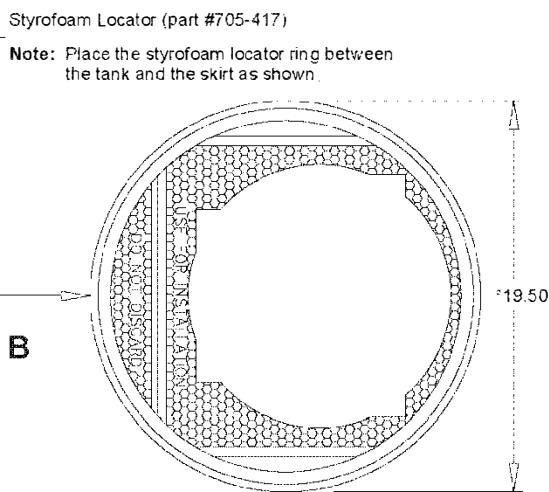

Figure B



Recommended Inside Riser Pipe Lengths for 5 Gallon Spill Containers

- 8 3/4"** - For conventional top and side seal adaptors (EBW 776 & 778)
- 7 3/4"** - For swivel type product adaptors and conventional coaxial adaptors (EBW 778 & 306)
- 6 3/4"** - For swivel type popped vapor adaptors and self-sealing coaxial popped adaptors (EBW 300 & 306 CA)

15 Gallon Spill Containers

Figure C

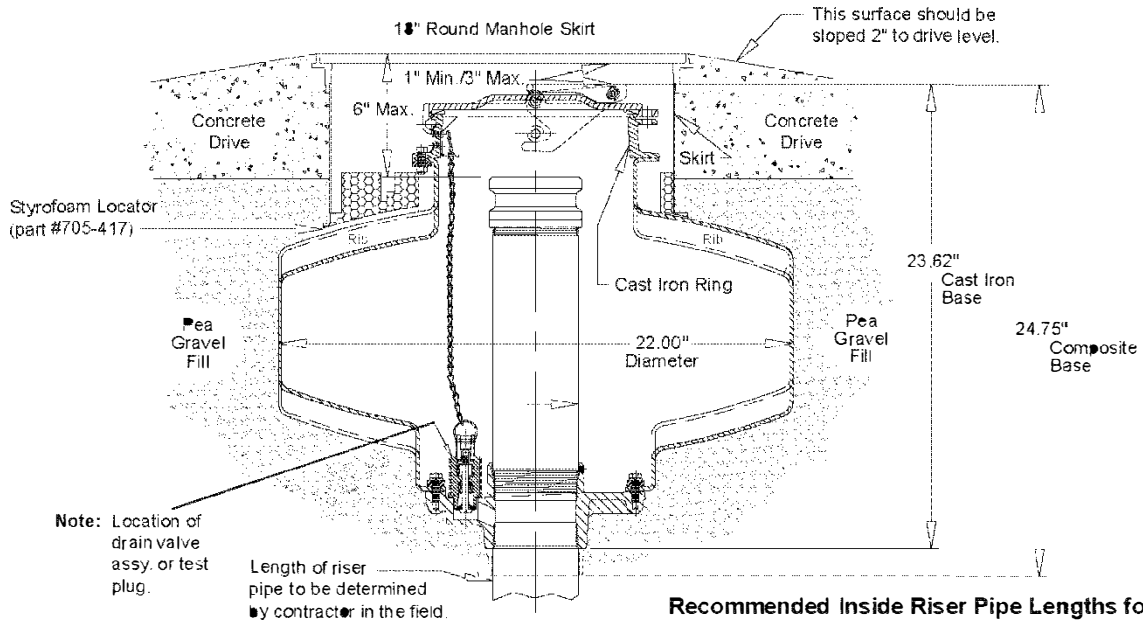

Recommended Inside Riser Pipe Lengths for 15 Gallon Spill Containers

- 13 1/2" - For conventional top and side seal adaptors (EBW 776 & 778)
- 12 1/2" - For swivel type product adaptors and conventional coaxial adaptors (EBW 778 & 306)
- 11 1/2" - For swivel type poppeted vapor adaptors and self-sealing coaxial poppeted adaptors (EBW 300 & 306 CA)

25 Gallon Spill Containers

Figure D

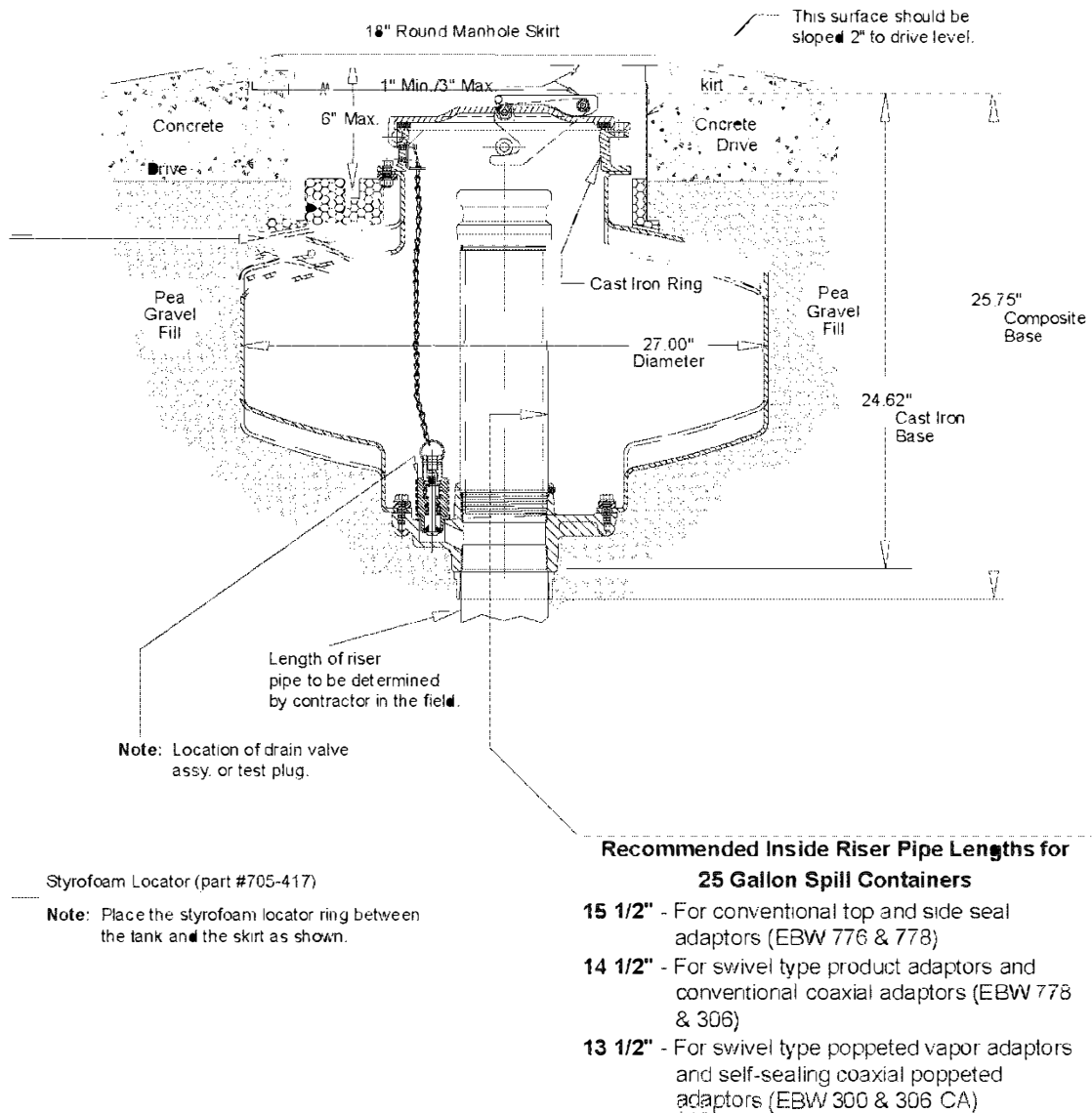

C.A.R.B. Approved Below Grade Spill Containers

Part No.	Size	Base	Drain	Replacement Drain Valve Kit	Fig.
705-492-01	5 Gal.	Cast Iron	Pull to Push	705-337-19	A
705-49202	5 Gal.	Cast Iron	No Drain		A
705-493-01	5 Gal.	Composite	Pull to Push	705-337-19	A
705-493-02	5 Gal.	Composite	No Drain		A
715-492-01	15 Gal.	Cast Iron	Pull to Push	705-337-19	C
715-49202	15 Gal.	Cast Iron	No Drain		C
715-49301	15 Gal.	Composite	Pull to Push	705-337-19	C
715-493-02	15 Gal.	Composite	No Drain		C
715-494-01	15 Gal.	Cast Iron	Pull to Push	705-337-19	C
715-494-02	15 Gal.	Cast Iron	No Drain		C
715-49501	15 Gal.	Composite	Pull to Push	705-337-19	C
715-495-02	15 Gal.	Composite	No Drain		C
725-492-01	25 Gal.	Cast Iron	Pull to Push	705-337-19	E
725-49202	25 Gal.	Cast Iron	No Drain		E
725-49301	25 Gal.	Composite	Pull to Push	705-337-19	E
725-493-02	25 Gal.	Composite	No Drain		E

[Drain Valve Leak Rate < 0.17 CFH @ 2.00" w.c]

Monthly Recommended Maintenance & Inspection Procedures

1. Clean/Remove any buildup of sand, gravel, or dirt from the manhole top cast flange. Buildup of material will prevent the manhole lid from sitting flat and diverting rain water. In addition to water infiltration, this can lead to premature lid failures and tripping hazards.
2. Inspect the spill container latching mechanism and make sure that it is operating properly.
3. Inspect the hinged cover gasket and replace it if necessary
4. Inspect the spill container for the presence of liquid. If any is present, identify the material (water or fuel) and dispose of it using your preferred acceptable method (pump it out or drain it into the tank).
5. Inspect the spill container and the drain valve screen for any foreign material collecting in the bottom of the tank. Remove any large objects (leaves, rags, etc.) and wipe the bottom of the tank with a disposable rag.
6. Inspect the tank riser adapter and the dust cap for obvious damage. Verify that the gasket is in the dust cap and that the dust cap still securely latches onto the adapter.

Post Installation Inspection Procedure

After installing these spill containers but prior to backfilling the excavation, EBW recommends that the tank system be checked for potential leaks. In CA, utilize TP-201.3, Static Pressure Test Procedure. In other areas, utilize this or a locally approved/accepted pressure test procedure. Should a leak be present, test the following with an acceptable leak check fluid: the tank and spill container piping joints, the drain valve poppet and gasket, the permanent drain blank plate gasket, and the adapter piping joint. **Repair all of the leaks prior to backfilling.**

Composite Base Spill Containment Installation Instructions

1. Before installing a spill containment manhole, apply PTFE thread sealant tape clockwise around the riser pipe threads.
2. Align the composite base on the riser pipe as shown in Figure A.
3. Rotate the spill containment counter clockwise until the threads mesh (you can feel the unit drop into place), then rotate it clockwise until it is handtight.



Caution  Do not use the upper cast iron ring to fully tighten the spill containment tank. Tightening the tank using the upper cast iron ring can cause undue stress to the entire unit.

4. To finish tightening, refer to Figure B and check p. 3 for torque specifications.
5. Continue with the standard instructions for setting the top rim to driveway grade level.

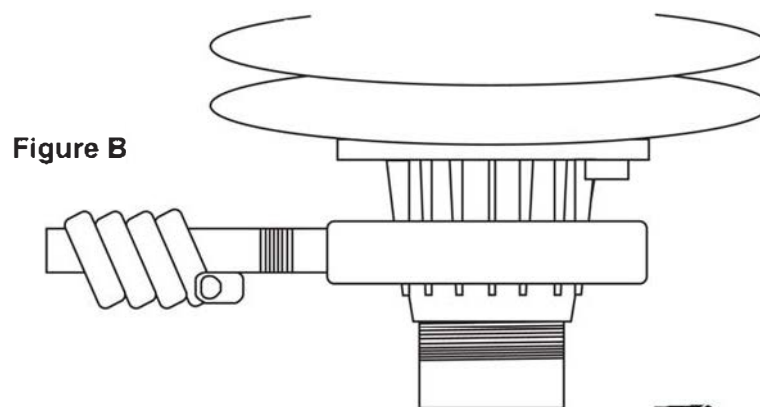

Franklin Fueling Systems

3760 Marsh Road
Madison WI 53718 U.S.A.
Tel: +1 608 838 8786
Tel: USA & Canada 1 800 225 9767

Figure M-7



Grade Level Spill Containment Manholes

Installation Instructions

705 - 5 Gallon 715 - 15 Gallon 725 - 25 Gallon



Manual #	Revision	Date	Changes from Previous Revision
F-1307	7	Mar. 2012	Removed reference to pipe sealant brand

Warning  Application and use of this product should be in compliance with local, state, and federal regulations. Selection of this product should be based on physical specifications, limitations, and compatibility with the environment and material to be handled. EBW makes no warranty of fitness for a particular use.

Part No.	Size	Base	Covers	Drain	Replacement Drain Valve Kit	Fig.
705-458-01	5 Gal.	Cast Iron	Raintight	No Drain	90022	B
705-470-01	5 Gal.	Cast Iron	Raintight	Pull to Push	705-332-19	B
705-470-21	5 Gal.	Cast Iron	Raintight	Pull to Push	705-332-19	B
705-471-01	5 Gal.	Composite	Raintight	Pull to Push	705-332-19	B
705-471-21	5 Gal.	Composite	Raintight	Pull to Push	705-332-19	B
705-472-01	5 Gal.	Cast Iron	Snap-on	Pull to Push	705-332-19	B
705-472-65	5 Gal.	Cast Iron	Snap-on	Pull to Push	705-332-19	B
705-473-01	5 Gal.	Composite	Snap-on	Pull to Push	705-337-01	B
705-473-65	5 Gal.	Composite	Snap-on	Pull to Push	705-332-19	B
705-478-EX	15 Gal.	Composite	Raintight	Pull to Push	705-332-19	C
715-470-01	15 Gal.	Cast Iron	Raintight	Pull to Push	705-332-19	C
715-471-01	15 Gal.	Composite	Raintight	Pull to Push	705-332-19	C
715-472-01	15 Gal.	Cast Iron	Snap-on	Pull to Push	705-332-19	C
715-472-65	15 Gal.	Cast Iron	Snap-on	Pull to Push	705-332-19	C
715-473-01	15 Gal.	Composite	Snap-on	Pull to Push	705-332-19	C
715-473-65	15 Gal.	Composite	Snap-on	Pull to Push	705-332-19	C
725-425-555	25 Gal.	Cast Iron	Raintight	Automatic	702-120-01	D
725-470-01	25 Gal.	Cast Iron	Raintight	Pull to Push	705-332-19	D
725-471-01	25 Gal.	Composite	Raintight	Pull to Push	705-332-19	D
725-472-01	25 Gal.	Cast Iron	Snap-on	Pull to Push	705-332-19	D
725-472-65	25 Gal.	Cast Iron	Snap-on	Pull to Push	705-332-19	D
725-473-01	25 Gal.	Composite	Snap-on	Pull to Push	705-332-19	D
725-473-65	25 Gal.	Composite	Snap-on	Pull to Push	705-332-19	D

ARB approved EVR components listed on page 7.

The following items may be ordered separately: Test Drain Kit (no drain) #90022 for models with pull to push drains and push drains.

Replacement Drain Valves for Models with Pull Drains

705-336-01	(5 Gal.)	B.G. & G.L.
705-336-02	(15 Gal.)	B.G. & G.L.
705-336-03	(25 Gal.)	B.G.
705-336-04	(25 Gal.)	G.L.

Conversion drain valve kit for models with push drains, order conversion kit 705-332-99.

EBW makes no expressed or implied warranty with regard to this guide's contents. EBW assumes no liability for errors or omissions, or for any damages, direct or consequential, that result from the use of this document or the equipment which it describes. This document contains proprietary information and is protected by copyright. All rights are reserved. No part of this document may be reproduced in any form without the prior written consent of EBW. EBW reserves the right to change this document at any time without notice.

Grade Level Spill Containment Manholes 705, 715, 725-GL (5,15, & 25 Gallon)

Installation Instructions

Before installing a spill container, coat all of the riser pipe threads with a thread sealant that is compatible with the product in that tank.

Install the spill container by threading it onto the tank riser pipe until it is hand tight. Do not use the upper cast iron ring to fully tighten the container. Tightening the tank using the upper cast iron ring can cause undue stress to the entire unit.

After hand tightening, place a torque wrench assembly around the lower portion of the tank base and torque the spill bucket base on a riser pipe to 60 - 90 ft. lbs. torque using an EBW chain wrench (part #901-101-01) and a torque wrench with at least 100 ft. lbs. of torque range (due to an offset of chain and torque wrenches, actual torque wrench values will be 45 - 70 ft. lbs.) After an initial torque value is obtained, continue to thread the tank base onto the riser pipe until the drain valve is orientated to the riser low spot.

Note: All of the tank risers have some out-of-plumb characteristics due to slight tank tilts and rolls. To properly drain, the drain valve must be located at the low spot of the riser tilt. The riser low spot is the direction the riser pipe is leaning towards. This is easily obtained by placing a small amount of water in the bucket base and turning the bucket until the water runs to the drain valve.

If space is limited (i.e. a retrofit installation to a sawed out section of concrete):

- 1) Make sure that the inside riser pipe is removed.
- 2) Locate the fitting that the inside riser pipe threads into.
- 3) Coming down through the top of the unit, use a special socket wrench on the octagonal surface of the fitting to finish tightening it. Do not disassemble the unit.

The top edge of the rim must be positioned a minimum of 2" above the driveway level to provide an adequate slope for drainage. Before pouring cement, place duct tape around the rim, this will keep the cement out of the drainage grooves when the lid is in place. See figure A. After cement has solidified, remove any duct tape or excess cement.

Note: If you want to seal off a drain to test your unit, install a test drain kit (part #90022-01)

Check For Leaks

Every unit should be tested for leaks prior to, and after, pouring concrete. If this model comes with a drain, close it. If not, install a 90022-01 test drain kit. Fill the unit completely with water. If the test water level drops at all within one hour, then a leak exists (this is not an EVR test).

Check to see that the drain valve is seated properly. If not, then PULL the drain valve several times on a PULL TO PUSH DRAIN UNIT. Replace the valve if it continues to leak.

If the unit continues to leak, the entire spill container must be removed from the riser pipe and replaced with another. RE-TEST.

After backfilling the area with pea gravel and pouring concrete, RE-TEST to make sure that no damage occurred during installation.

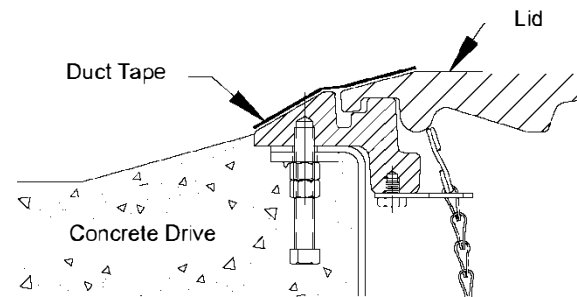
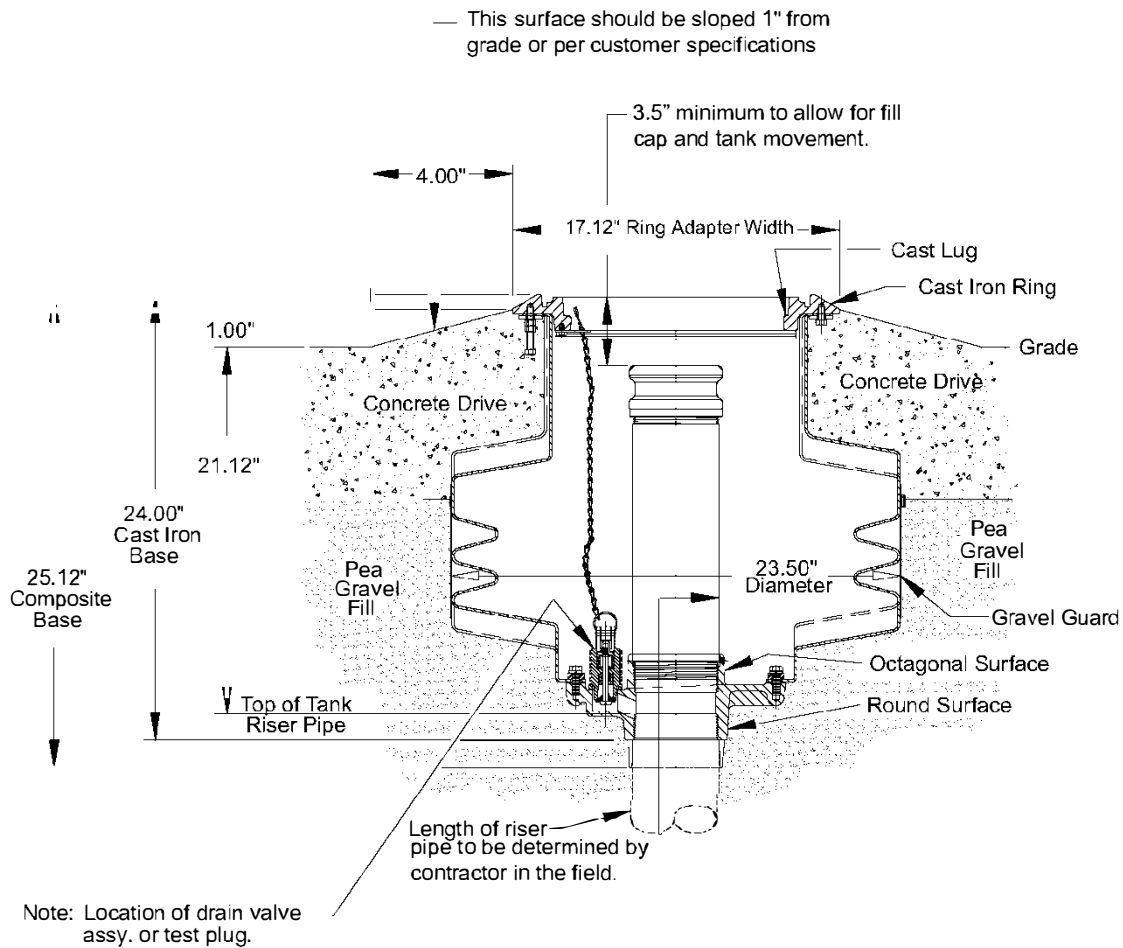

Figure A: Protect drainage grooves

15 Gallon Spill Containers

Figure C: 15 Gallon Installation



Recommended Inside Riser Pipe Lengths for 15 Gallon Spill Containers

12 1/4" - For conventional top and side seal adaptors (EBW 776 & 778)

11 1/4" - For swivel type product adaptors and conventional coaxial adaptors (EBW 778 & 306)

10 1/4" - For swivel type poppeted vapor adaptors and self-sealing coaxial poppeted adaptors (EBW 300 & 306 CA)

The above figures may contain components (including part numbers) that have not been certified by the California Air Resources Board (CARB) for a specific Phase I Vapor Recovery System. Please refer to Exhibit 1 of the appropriate CARB Phase I Executive Order for a list of Phase I Vapor Recovery System Equipment.

25 Gallon Spill Containers

Figure D: 25 Gallon Installation

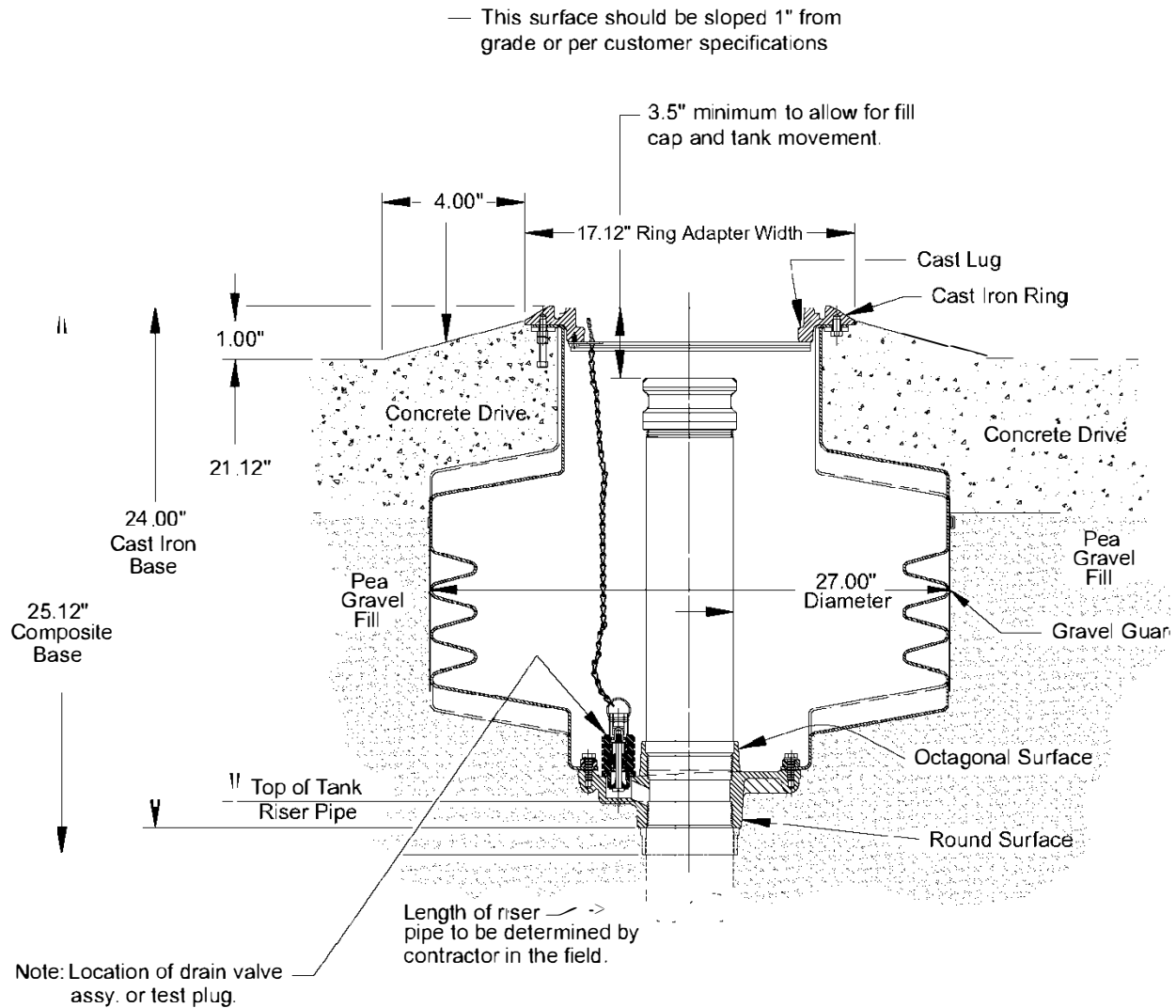

Recommended Inside Riser Pipe Lengths for 25 Gallon Spill Containers

16" - For conventional top and side seal adaptors (EBW 776 & 778)

15" - For swivel type product adaptors and conventional coaxial adaptors (EBW 778 & 306)

14" - For swivel type poppeted vapor adaptors and self-sealing coaxial poppeted adaptors (EBW 300 & 306 CA)

The above figures may contain components (including part numbers) that have not been certified by the California Air Resources Board (CARB) for a specific Phase I Vapor Recovery System. Please refer to Exhibit 1 of the appropriate CARB Phase I Executive Order for a list of Phase I Vapor Recovery System Equipment.

C.A.R.B. Approved Below Grade Spill Containers

Part No.	Size	Base	Covers	Drain	Replacement Drain Valve Kit	Fig.
705-490-01	5 Gal.	Cast Iron	Raintight	Pull to Push	705-337-19	B
705-490-02	5 Gal.	Cast Iron	Raintight	No Drain		B
705-490-03	5 Gal.	Cast Iron	Watertight	Pull to Push	705-337-19	B
705-490-04	5 Gal.	Cast Iron	Watertight	No Drain		B
705-491-01	5 Gal.	Composite	Raintight	Pull to Push	705-337-19	B
705-491-02	5 Gal.	Composite	Raintight	No Drain		B
705-491-03	5 Gal.	Composite	Watertight	Pull to Push	705-337-19	B
705-491-04	5 Gal.	Composite	Watertight	No Drain		B
715-490-01	15 Gal.	Cast Iron	Raintight	Pull to Push	705-337-19	C
715-490-02	15 Gal.	Cast Iron	Raintight	No Drain		C
715-490-03	15 Gal.	Cast Iron	Watertight	Pull to Push	705-337-19	C
715-490-04	15 Gal.	Cast Iron	Watertight	No Drain		C
715-491-01	15 Gal.	Composite	Raintight	Pull to Push	705-337-19	C
715-491-02	15 Gal.	Composite	Raintight	No Drain		C
715-491-03	15 Gal.	Composite	Watertight	Pull to Push	705-337-19	C
715-491-04	15 Gal.	Composite	Watertight	No Drain		C
725-490-01	25 Gal.	Cast Iron	Raintight	Pull to Push	705-337-19	D
725-490-02	25 Gal.	Cast Iron	Raintight	No Drain		D
725-490-03	25 Gal.	Cast Iron	Watertight	Pull to Push	705-337-19	D
725-490-04	25 Gal.	Cast Iron	Watertight	No Drain		D
725-491-01	25 Gal.	Composite	Raintight	Pull to Push	705-337-19	D
725-491-02	25 Gal.	Composite	Raintight	No Drain		D
725-491-03	25 Gal.	Composite	Watertight	Pull to Push	705-337-19	D
725-491-04	25 Gal.	Composite	Watertight	No Drain		D

Monthly Recommended Maintenance & Inspection Procedures

1. Clean/Remove any buildup of sand, gravel, or dirt from the manhole top cast flange. Buildup of material will prevent the manhole lid from sitting flat and diverting rain water. In addition to water infiltration, this can lead to premature lid failures and tripping hazards.
2. Inspect the spill container latching mechanism and make sure that it is operating properly.
3. Inspect the hinged cover gasket and replace it if necessary.
4. Inspect the spill container for the presence of liquid. If any is present, identify the material (water or fuel) and dispose of it using your preferred acceptable method (pump it out or drain it into the tank).
5. Inspect the spill container and the drain valve screen for any foreign material collecting in the bottom of the tank. Remove any large objects (leaves, rags, etc.) and wipe the bottom of the tank with a disposable rag.
6. Inspect the tank riser adapter and the dust cap for obvious damage. Verify that the gasket is in the dust cap and that the dust cap still securely latches onto the adapter.

Post Installation Inspection Procedure

After installing these spill containers, but prior to backfilling the excavation, EBW recommends that the tank system be checked for potential leaks. In CA, utilize TP-201.3, Static Pressure Test Procedure. In other areas, utilize this or a locally approved/accepted pressure test procedure. Should a leak be present, test the following with an acceptable leak check fluid: the tank and spill container piping joints, the drain valve poppet and gasket, the permanent drain blank plate gasket, and the adapter piping joint. Repair all of the leaks prior to backfilling.

Composite Base Spill Containment Installation Instructions

1. Before installing a spill containment manhole, apply PTFE thread sealant tape clockwise around the riser pipe threads.
2. Align the composite base on the riser pipe as shown in Figure E.
3. Rotate the spill containment counter clockwise until the threads mesh (you can feel the unit drop into place), then rotate it clockwise until it is handtight.

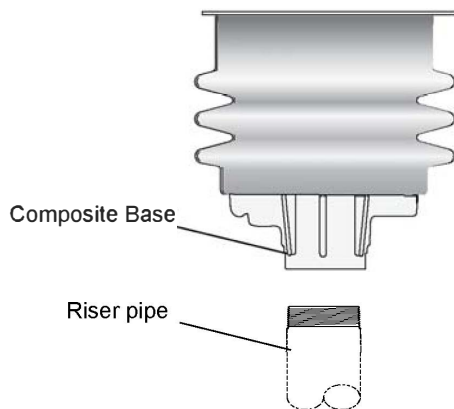

Caution  Do not use the upper cast iron ring to fully tighten the spill containment tank. Tightening the tank using the upper cast iron ring can cause undue stress to the entire unit.

Figure E

4. To finish tightening, refer to Figure F and check p. 3 for torque specifications.
5. Continue with the standard instructions for setting the top rim to driveway grade level.

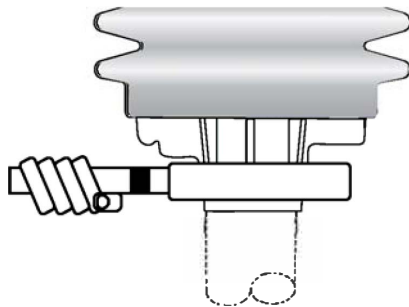

Figure F

Franklin Fueling Systems

3760 Marsh Road • Madison, WI 53718 U.S.A.
Tel: +1 608 838 8786 • Fax: +1 608 838 6433 • www.franklinfueling.com
Tel: USA & Canada 1 800 225 9787 • Tel: Mexico 001 800 738 7610

Figure M-8

Drain Valve Assembly

Replacement Instructions

Model 705-337-29

Drain Valve Replacement Kit

Replacement

1. Remove existing valve assembly and gasket.
2. Install the new drain assembly (item 1) and new gasket (item 2).
3. Install new screws (Item 3) and **Torque them to 50-75 inch-pounds.**

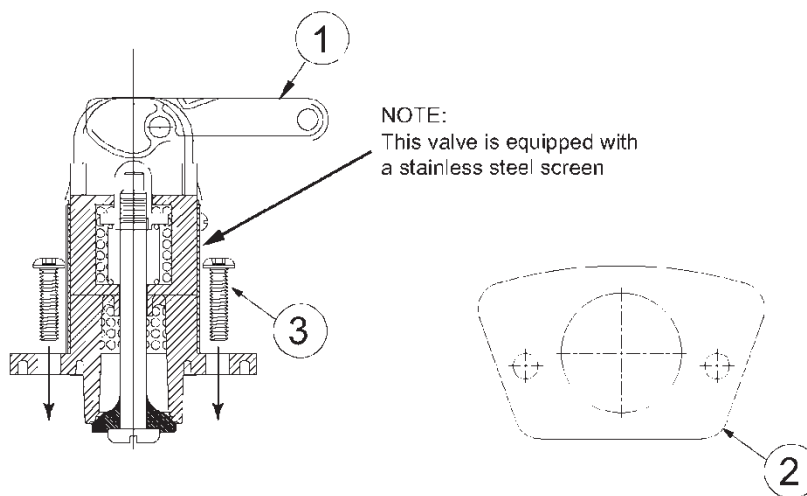

**Figure N-1: Typical Product Side Installation of Defender Series Spill Container:
Single Wall Direct Bury Configuration**

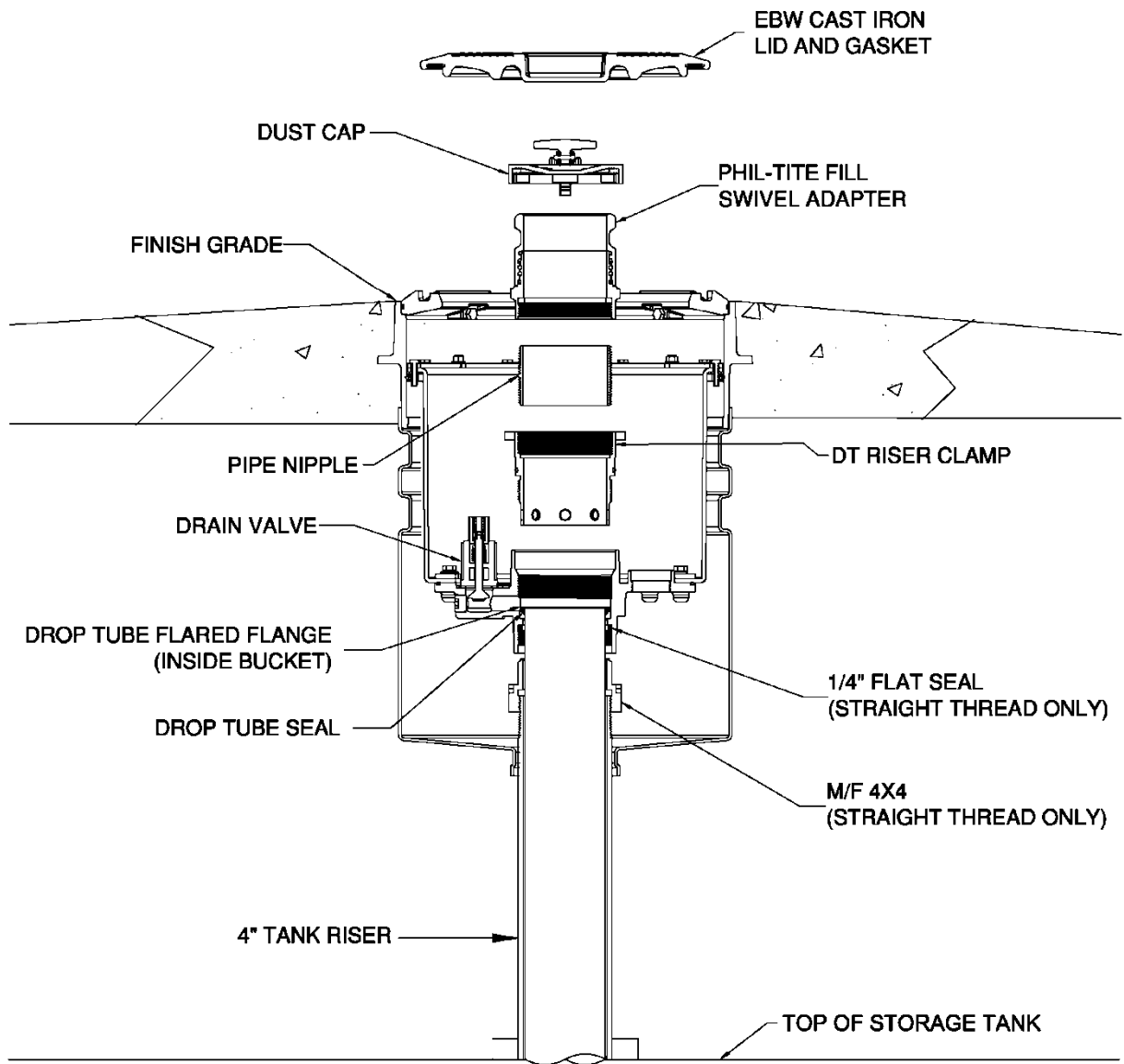

**Figure N-2: Typical Product Side Installation of Defender Series Spill Container:
Double Wall Direct Bury Configuration with I² Monitor**

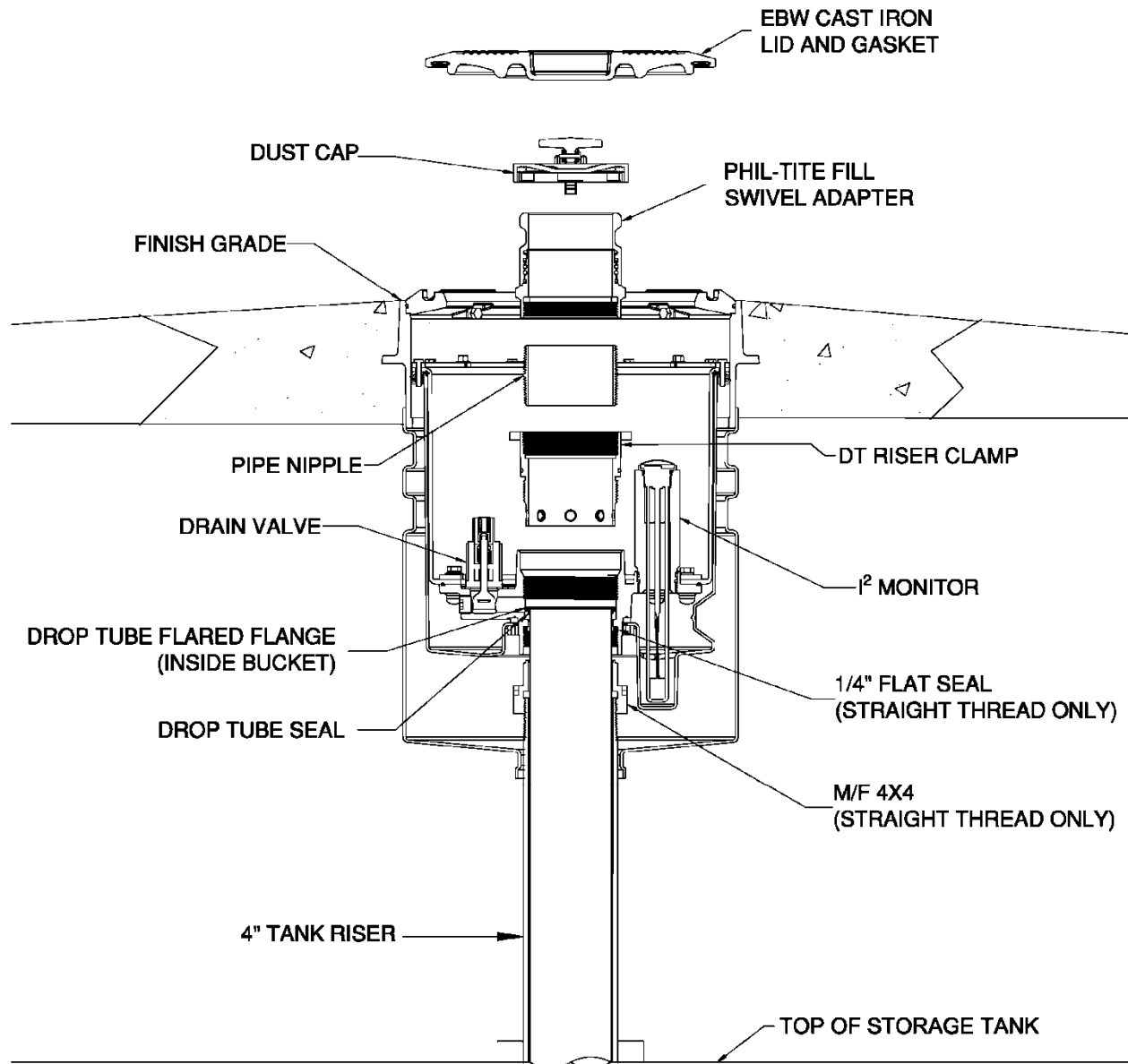

**Figure N-3: Typical Product Side Installation of Defender Series Spill Container:
Double Wall Direct Bury Configuration with TSP-ULS Liquid Sensor**

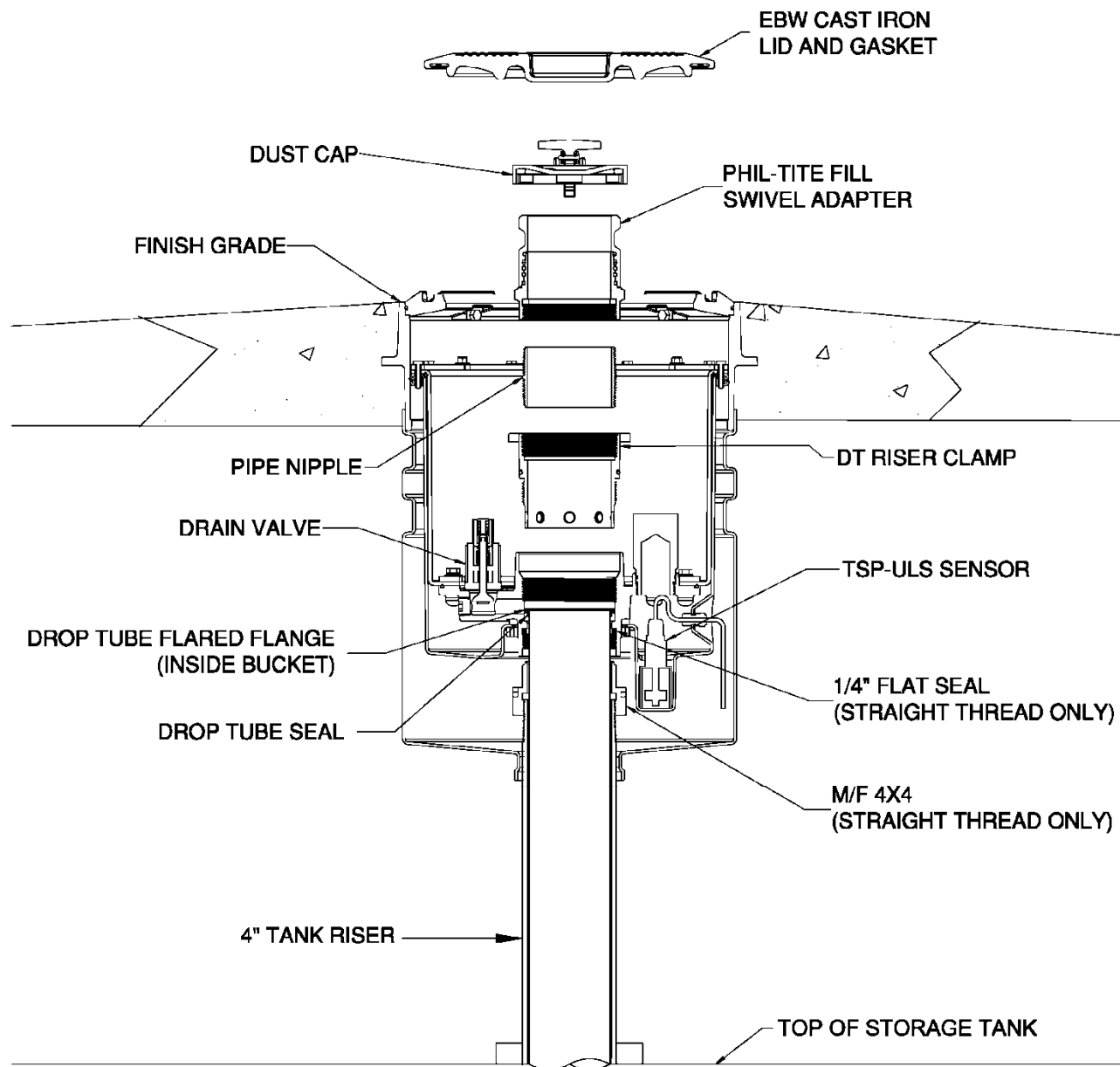

**Figure N-4: Typical Vapor Recovery Side Installation of Defender Series Spill Container
Single Wall Direct Bury Configuration**

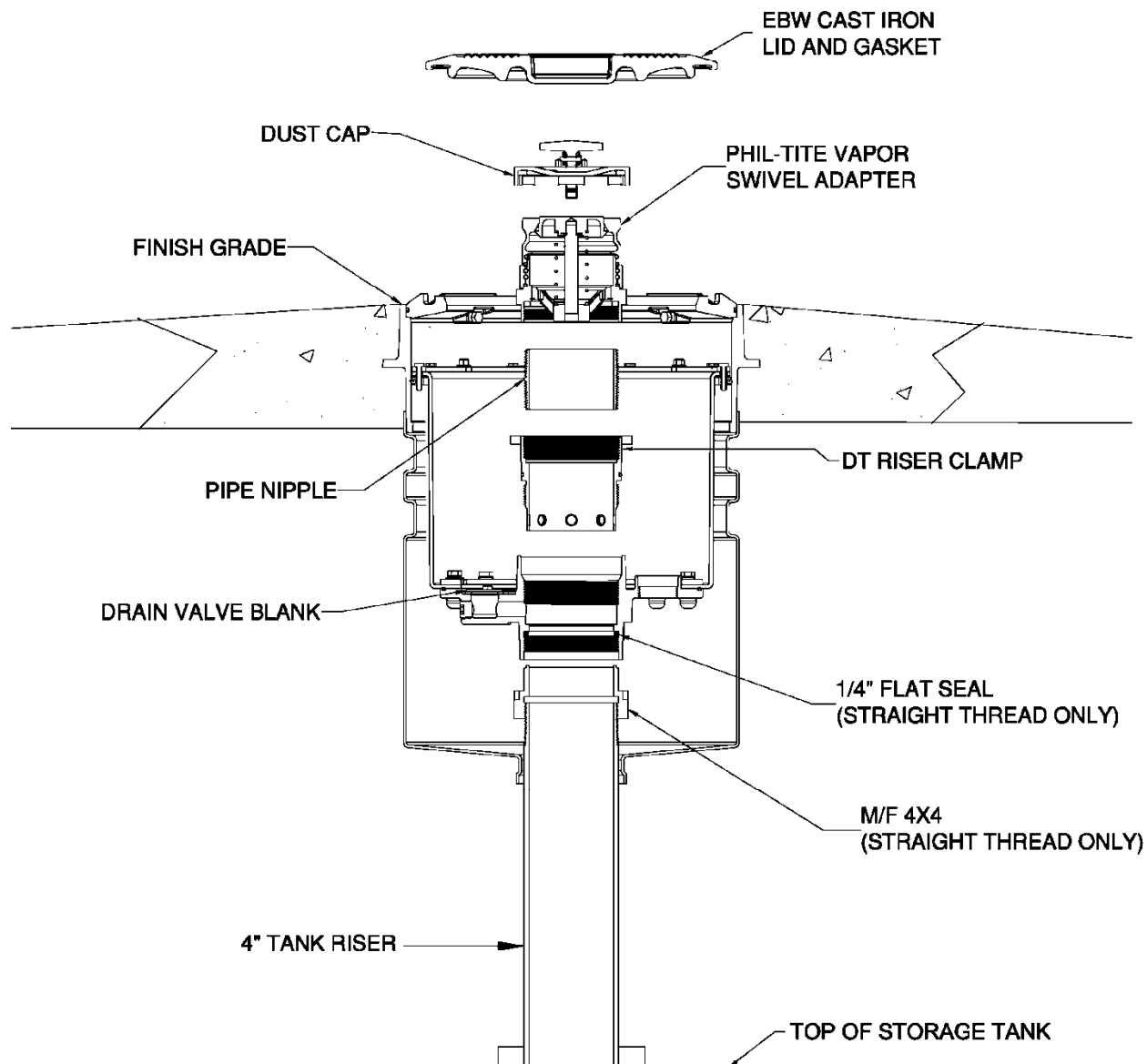

**Figure N-5: Typical Vapor Recovery Side Installation of Defender Series Spill Container
Double Wall Direct Bury Configuration with I² Monitor**

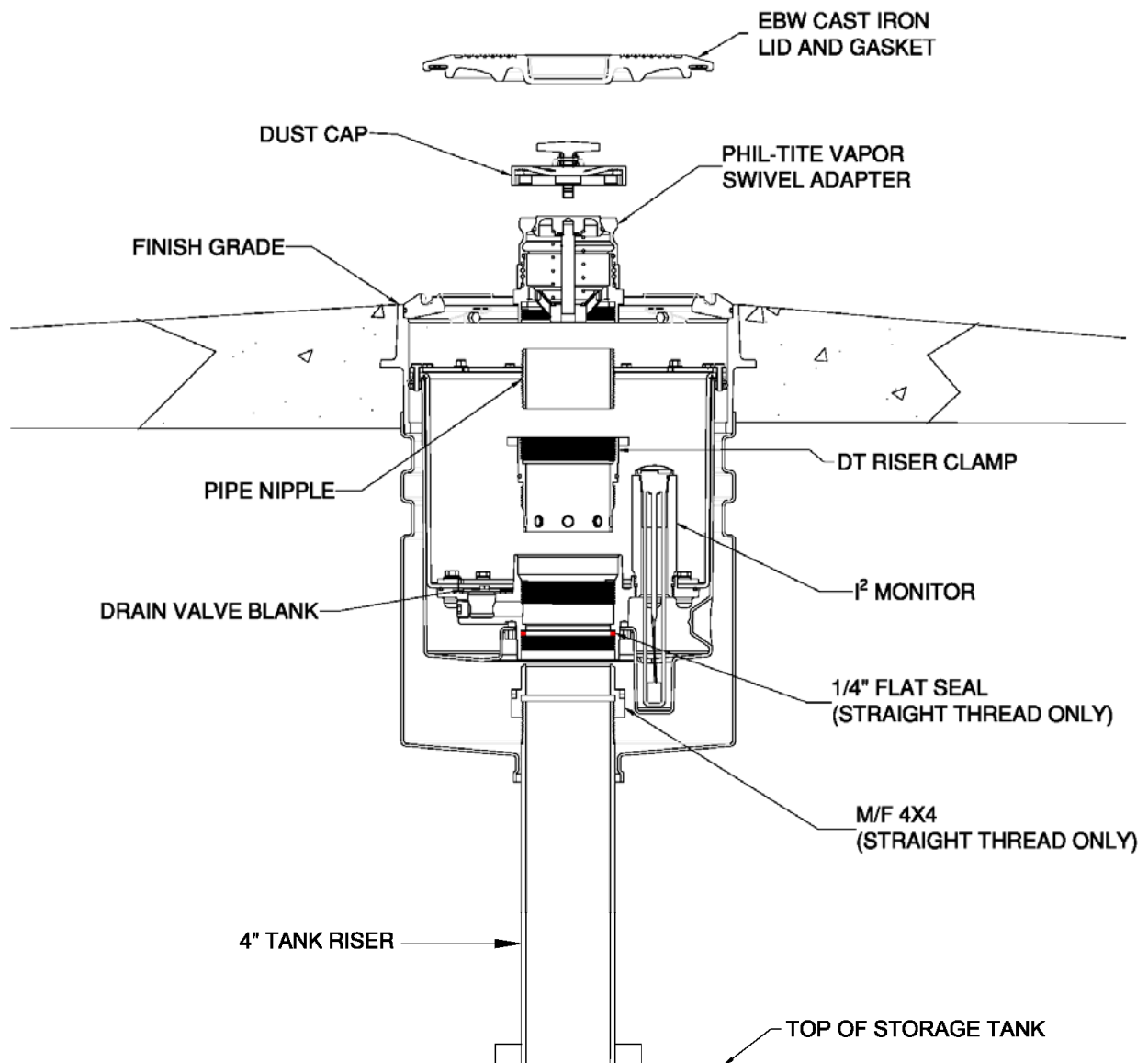

**Figure N-6: Typical Vapor Recovery Side Installation of Defender Series Spill Container
Double Wall Direct Bury Configuration with TSP-ULS Liquid Sensor**

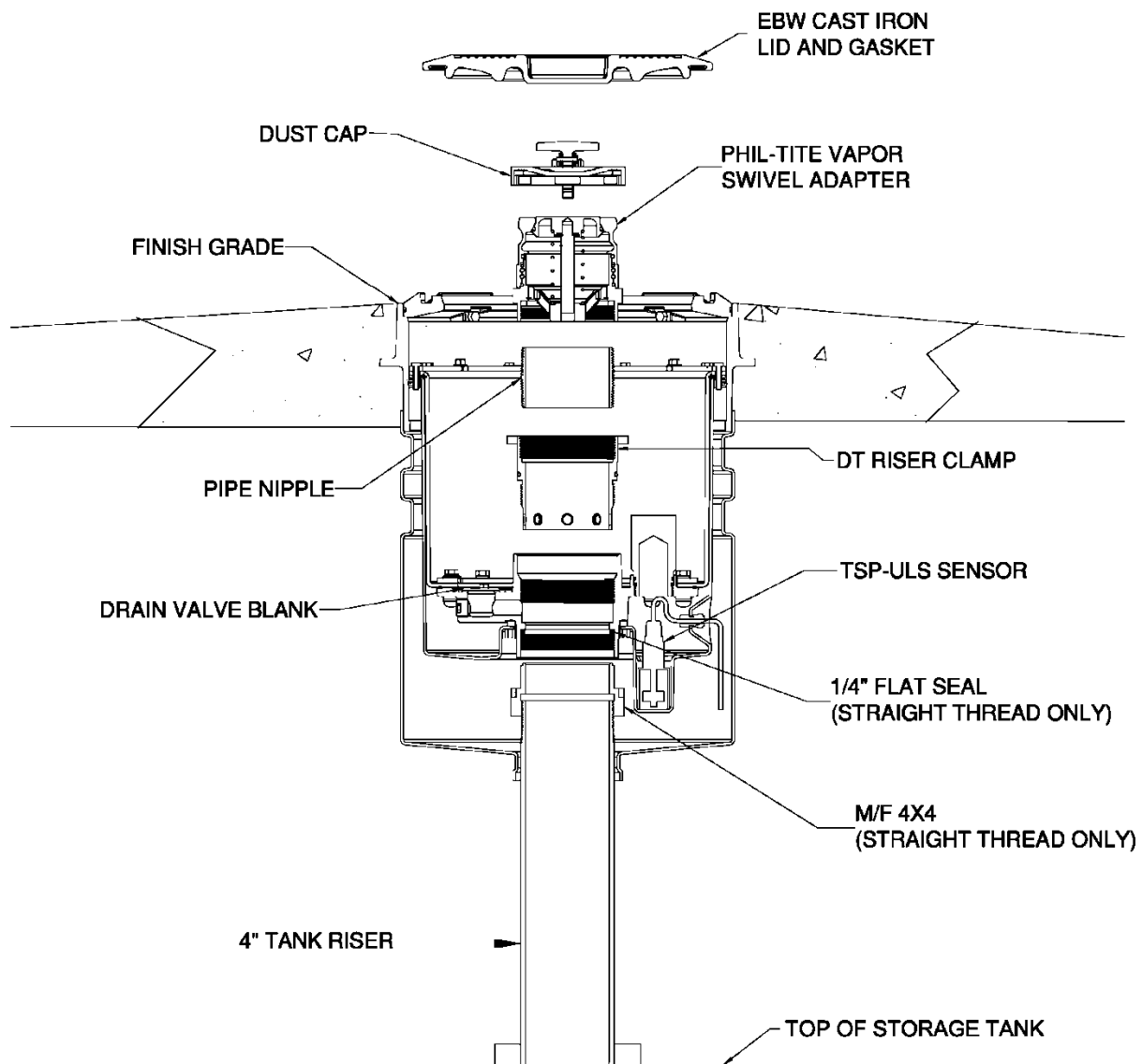

Figure O-1: McGard Fuel Lock

Fuel Lock Installation Guide

Note: A removal and installation of components must be performed by technicians certified by the appropriate manufacturer of the Phase I system.

For a video of these instructions go to:

<http://mcard.com/index.php/municipal-security-videos>

1 Remove spill container cover.



2 Remove seal cap.



3 Remove adapter.



4 Attach lock onto hanger.



5 Place key tool in lock and tether to wrist.



- 6** Holding hanger, place the lock in pipe/fitting. If installing a lock with dual cross-webs or applications without a drop tube and/or (overflow valve, proceed to step 7. If overflow valve is present, align the stick of the two openings) in the center of the lock with overflow prevention valve (viewed down)

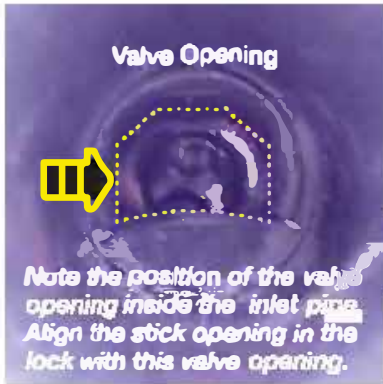

- 7** Tighten one mounting screw until tip is in contact with ID of pipe/fitting, while roughly centering the lock in the pipe/fitting. Leaving lock and hanger in place, remove and reinstall key tool to tighten second mounting screw until snug enough to hold lock in place. Do not over-tighten.



- 8** Remove key tool and hanger and tightly reinstall adapter.



- 9** Re-install key tool into lock, through adapter and tighten screws firmly. Remove key tool.



- 10** Install seal cap.

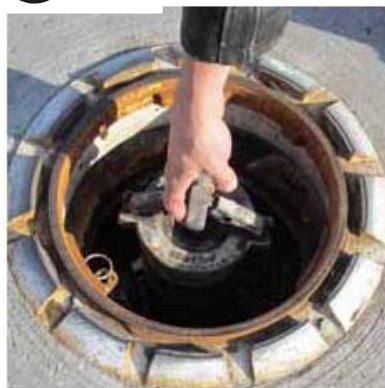

- 11** Install spill container cover.



Isolation Instructions for Drop Tubes Utilizing a McGard Fuel Lock

Spill containment drain valves and 4" ID drop tubes must be isolated when performing CA EVR leak test procedures identified in TP-201.1D. In applications using the McGard Fuel Lock, a nitrile test bladder (balloon) encased in a protective fabric bag is used to plug the tube, as follows:

1. The bladder (Item #1) is inserted (fully deflated) through the lock and into the drop tube and positioned at desired point of isolation. **To achieve a bubble tight seal, the fabric protection bag must be soaked (wetted) with oil prior to use. This can be any available motor oil such as 30W or 10W-30.** A 3' extension hose (Item #2) may be used if deeper test point is required.
2. After installation, the bladder is inflated to 15 psi utilizing a basic hand pump or low pressure compressed air (**DO NOT OVER-INFLATE**) and a pressure gage (Item #3). All connections are standard tire valve stems (Schrader Valves).
3. After inflation, disconnect pump and/or gage so test bladder hose can be curled and placed into the drop tube.
4. Install test cap on product adapter and perform leak test procedure.
5. After testing is completed, connect pressure gage (with bleeder valve, Item #3) or remove needle from Schrader valve and manual bleeder valve to fully deflate test bladder. Remove the test bladder from the drop tube and store in a clean (dirt free) plastic bag.

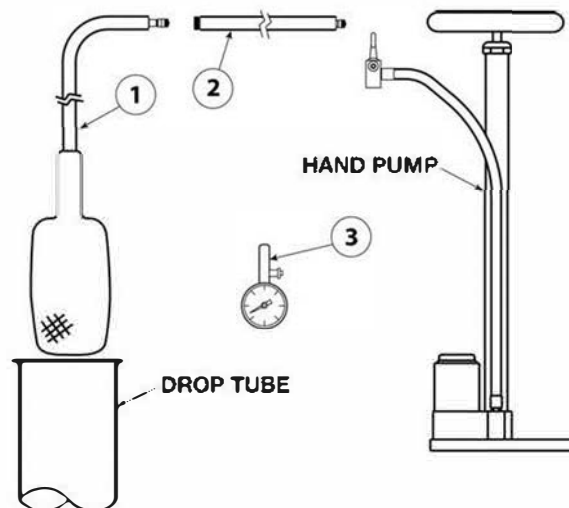

Item	Part Name	Manufacturer	Manufacturer Part No.	Qty
1	Bladder Plug	COB Industries	PSI104	1
2	3 ft. Extension Hose	Cherne Industries	274038	1
3	Pressure Gage w/Bleed Valve	Westward Tools	2HKY6	1